

Calculus

Assignment Problems

Paul Dawkins

Table of Contents

Preface	vi
Outline	viii
1 Review	1
1.1 Functions	2
1.2 Inverse Functions	6
1.3 Trig Functions	7
1.4 Solving Trig Equations	9
1.5 Solving Trig Equations with Calculators, Part I	10
1.6 Solving Trig Equations with Calculators, Part II	11
1.7 Exponential Functions	12
1.8 Logarithm Functions	13
1.9 Exponential And Logarithm Equations	14
1.10 Common Graphs	17
2 Limits	19
2.1 Tangent Lines And Rates Of Change	20
2.2 The Limit	24
2.3 One-Sided Limits	28
2.4 Limit Properties	31
2.5 Computing Limits	33
2.6 Infinite Limits	36
2.7 Limits at Infinity, Part I	38
2.8 Limits at Infinity, Part II	40
2.9 Continuity	42
2.10 The Definition of the Limit	47
3 Derivatives	48
3.1 The Definition of the Derivative	50
3.2 Interpretation of the Derivative	52
3.3 Differentiation Formulas	57
3.4 Product and Quotient Rule	60
3.5 Derivatives of Trig Functions	62
3.6 Derivatives of Exponentials & Logarithms	64

Table of Contents

3.7	Derivatives of Inverse Trig Functions	65
3.8	Derivatives of Hyperbolic Functions	66
3.9	Chain Rule	67
3.10	Implicit Differentiation	70
3.11	Related Rates	72
3.12	Higher Order Derivatives	81
3.13	Logarithmic Differentiation	83
4	Derivative Applications	84
4.1	Rates of Change	86
4.2	Critical Points	87
4.3	Minimum and Maximum Values	91
4.4	Finding Absolute Extrema	95
4.5	The Shape of a Graph, Part I	97
4.6	The Shape of a Graph, Part II	104
4.7	The Mean Value Theorem	109
4.8	Optimization	110
4.9	More Optimization	114
4.10	L'Hospital's Rule	119
4.11	Linear Approximations	121
4.12	Differentials	122
4.13	Newton's Method	123
4.14	Business Applications	125
5	Integrals	127
5.1	Indefinite Integrals	128
5.2	Computing Indefinite Integrals	130
5.3	Substitution Rule for Indefinite Integrals	133
5.4	More Substitution Rule	136
5.5	Area Problem	138
5.6	Definition of the Definite Integral	139
5.7	Computing Definite Integrals	141
5.8	Substitution Rule for Definite Integrals	144
6	Applications of Integrals	146
6.1	Average Function Value	147
6.2	Area Between Curves	148
6.3	Volume with Rings	150
6.4	Volume with Cylinders	152
6.5	More Volume Problems	154
6.6	Work	157
7	Integration Techniques	158
7.1	Integration by Parts	161

Table of Contents

7.2	Integrals Involving Trig Functions	163
7.3	Trig Substitutions	165
7.4	Partial Fractions	167
7.5	Integrals Involving Roots	169
7.6	Integrals Involving Quadratics	170
7.7	Integration Strategy	171
7.8	Improper Integrals	172
7.9	Comparison Test for Improper Integrals	174
7.10	Approximating Definite Integrals	175
8	More Applications of Integrals	176
8.1	Arc Length	177
8.2	Surface Area	178
8.3	Center Of Mass	180
8.4	Hydrostatic Pressure and Force	181
8.5	Probability	184
9	Parametric and Polar	186
9.1	Parametric Equations	187
9.2	Tangents with Parametric Equations	190
9.3	Area with Parametric Equations	191
9.4	Arc Length with Parametric Equations	192
9.5	Surface Area with Parametric Equations	193
9.6	Polar Coordinates	194
9.7	Tangents with Polar Coordinates	196
9.8	Area with Polar Coordinates	197
9.9	Arc Length with Polar Coordinates	198
9.10	Surface Area with Polar Coordinates	199
9.11	Arc Length and Surface Area Revisited	200
10	Series and Sequences	201
10.1	Sequences	202
10.2	More on Sequences	203
10.3	Series - Basics	204
10.4	Convergence & Divergence of Series	205
10.5	Special Series	207
10.6	Integral Test	208
10.7	Comparison & Limit Comparison Test	209
10.8	Alternating Series Test	210
10.9	Absolute Convergence	211
10.10	Ratio Test	212
10.11	Root Test	213
10.12	Strategy for Series	214
10.13	Estimating the Value of a Series	215

Table of Contents

10.14	Power Series	216
10.15	Power Series and Functions	217
10.16	Taylor Series	218
10.17	Applications of Series	219
10.18	Binomial Series	220
11	Vectors	221
11.1	Basic Concepts	222
11.2	Vector Arithmetic	223
11.3	Dot Product	225
11.4	Cross Product	227
12	3 Dimensional Space	228
12.1	The 3-D Coordinate System	229
12.2	Equations of Lines	230
12.3	Equations of Planes	231
12.4	Quadric Surfaces	233
12.5	Functions of Several Variables	234
12.6	Vector Functions	235
12.7	Calculus with Vector Functions	236
12.8	Tangent Normal Vectors	238
12.9	Arc Length with Vector Functions	239
12.10	Curvature	240
12.11	Velocity and Acceleration	241
12.12	Cylindrical Coordinates	242
12.13	Spherical Coordinates	243
13	Partial Derivatives	244
13.1	Limits	245
13.2	Partial Derivatives	246
13.3	Interpretations of Partial Derivatives	247
13.4	Higher Order Partial Derivatives	248
13.5	Differentials	249
13.6	Chain Rule	250
13.7	Directional Derivatives	252
14	Applications of Partial Derivatives	254
14.1	Tangent Planes	255
14.2	Gradient Vector	256
14.3	Relative Extrema	257
14.4	Relative Extrema	258
14.5	Lagrange Multipliers	259
15	Multiple Integrals	260
15.1	Double Integrals	261

Table of Contents

15.2	Iterated Integrals	262
15.3	Double Integrals over General Regions	264
15.4	Double Integrals in Polar Coordinates	268
15.5	Triple Integrals	270
15.6	Triple Integrals in Cylindrical Coordinates	272
15.7	Triple Integrals in Spherical Coordinates	273
15.8	Change of Variables	274
15.9	Surface Area	276
15.10	Area and Volume Revisited	277
16	Line Integrals	278
16.1	Vector Fields	279
16.2	Line Integrals - Part I	280
16.3	Line Integrals - Part II	283
16.4	Line Integrals of Vector Fields	285
16.5	Fundamental Theorem for Line Integrals	288
16.6	Conservative Vector Fields	290
16.7	Green's Theorem	292
17	Surface Integrals	296
17.1	Curl and Divergence	297
17.2	Parametric Surfaces	298
17.3	Surface Integrals	300
17.4	Surface Integrals of Vector Fields	301
17.5	Stokes' Theorem	302
17.6	Divergence Theorem	304
	Index	305

Preface

First, here's a little bit of history on how this material was created (there's a reason for this, I promise). A long time ago (2002 or so) when I decided I wanted to put some mathematics stuff on the web I wanted a format for the source documents that could produce both a pdf version as well as a web version of the material. After some investigation I decided to use MS Word and MathType as the easiest/quickest method for doing that. The result was a pretty ugly HTML (*i.e.* web page code) and had the drawback of the mathematics were images which made editing the mathematics painful. However, it was the quickest way of dealing with this stuff.

Fast forward a few years (don't recall how many at this point) and the web had matured enough that it was now much easier to write mathematics in \LaTeX (<https://en.wikipedia.org/wiki/LaTeX>) and have it display on the web (\LaTeX was my first choice for writing the source documents). So, I found a tool that could convert the MS Word mathematics in the source documents to \LaTeX . It wasn't perfect and I had to write some custom rules to help with the conversion but it was able to do it without "messing" with the mathematics and so I didn't need to worry about any math errors being introduced in the conversion process. The only problem with the tool is that all it could do was convert the mathematics and not the rest of the source document into \LaTeX . That meant I just converted the math into \LaTeX for the website but didn't convert the source documents.

Now, here's the reason for this history lesson. Fast forward even more years and I decided that I really needed to convert the source documents into \LaTeX as that would just make my life easier and I'd be able to enable working links in the pdf as well as a simple way of producing an index for the material. The only issue is that the original tool I'd use to convert the MS Word mathematics had become, shall we say, unreliable and so that was no longer an option and it still has the problem on not converting anything else into proper \LaTeX code.

So, the best option that I had available to me is to take the web pages, which already had the mathematics in proper \LaTeX format, and convert the rest of the HTML into \LaTeX code. I wrote a set of tools to do this and, for the most part, did a pretty decent job. The only problem is that the tools weren't perfect. So, if you run into some "odd" stuff here (things like `<sup>`, ``, ``, `<div>`, *etc.*) please let me know the section with the code that I missed. I did my best to find all the "orphaned" HTML code but I'm certain I missed some on occasion as I did find my eyes glazing over every once in a while as I went over the converted document.

Now, with that out of the way, here are a set of assignment problems for the Calculus notes. Please note that these problems do not have any solutions available. These are intended mostly for instructors who might want a set of problems to assign for turning in. Having solutions available (or even just final answers) would defeat the purpose of the problems.

Preface

If you are looking for some practice problems (with solutions available) please check out the [Practice Problems](#). There you will find a set of problems that should give you quite a bit practice.

Outline

Here is a listing of sections for which assignment problems have been written as well as a brief description of the material covered in the notes for that particular section.

Please note that these problems do not have any solutions available. These are intended mostly for instructors who might want a set of problems to assign for turning in. Having solutions available (or even just final answers) would defeat the purpose of the problems.

If you are looking for some practice problems (with solutions available) please check out the [Practice Problems](#). There you will find a set of problems that should give you quite a bit practice.

[Review](#) - In this chapter we give a brief review of selected topics from Algebra and Trig that are vital to surviving a Calculus course. Included are Functions, Trig Functions, Solving Trig Equations, Exponential/Logarithm Functions and Solving Exponential/Logarithm Equations.

[Functions](#) - In this section we will cover function notation/evaluation, determining the domain and range of a function and function composition.

[Inverse Functions](#) - In this section we will define an inverse function and the notation used for inverse functions. We will also discuss the process for finding an inverse function.

[Trig Functions](#) - In this section we will give a quick review of trig functions. We will cover the basic notation, relationship between the trig functions, the right triangle definition of the trig functions. We will also cover evaluation of trig functions as well as the unit circle (one of the most important ideas from a trig class!) and how it can be used to evaluate trig functions.

[Solving Trig Equations](#) - In this section we will discuss how to solve trig equations. The answers to the equations in this section will all be one of the “standard” angles that most students have memorized after a trig class. However, the process used here can be used for any answer regardless of it being one of the standard angles or not.

[Solving Trig Equations with Calculators, Part I](#) - In this section we will discuss solving trig equations when the answer will (generally) require the use of a calculator (*i.e.* they aren't one of the standard angles). Note however, the process used here is identical to that for when the answer is one of the standard angles. The only difference is that the answers in here can be a little messy due to the need of a calculator. Included is a brief discussion of inverse trig functions.

[Solving Trig Equations with Calculators, Part II](#) - In this section we will continue our discussion

of solving trig equations when a calculator is needed to get the answer. The equations in this section tend to be a little trickier than the "normal" trig equation and are not always covered in a trig class.

Exponential Functions - In this section we will discuss exponential functions. We will cover the basic definition of an exponential function, the natural exponential function, i.e. e^x , as well as the properties and graphs of exponential functions

Logarithm Functions - In this section we will discuss logarithm functions, evaluation of logarithms and their properties. We will discuss many of the basic manipulations of logarithms that commonly occur in Calculus (and higher) classes. Included is a discussion of the natural ($\ln(x)$) and common logarithm ($\log(x)$) as well as the change of base formula.

Exponential and Logarithm Equations - In this section we will discuss various methods for solving equations that involve exponential functions or logarithm functions.

Common Graphs - In this section we will do a very quick review of many of the most common functions and their graphs that typically show up in a Calculus class.

Limits - In this chapter we introduce the concept of limits. We will discuss the interpretation/meaning of a limit, how to evaluate limits, the definition and evaluation of one-sided limits, evaluation of infinite limits, evaluation of limits at infinity, continuity and the Intermediate Value Theorem. We will also give a brief introduction to a precise definition of the limit and how to use it to evaluate limits.

Tangent Lines and Rates of Change - In this section we will introduce two problems that we will see time and again in this course : Rate of Change of a function and Tangent Lines to functions. Both of these problems will be used to introduce the concept of limits, although we won't formally give the definition or notation until the next section.

The Limit - In this section we will introduce the notation of the limit. We will also take a conceptual look at limits and try to get a grasp on just what they are and what they can tell us. We will be estimating the value of limits in this section to help us understand what they tell us. We will actually start computing limits in a couple of sections.

One-Sided Limits - In this section we will introduce the concept of one-sided limits. We will discuss the differences between one-sided limits and limits as well as how they are related to each other.

Limit Properties - In this section we will discuss the properties of limits that we'll need to use in computing limits (as opposed to estimating them as we've done to this point). We will also compute a couple of basic limits in this section.

Computing Limits - In this section we will look at several types of limits that require some work before we can use the limit properties to compute them. We will also look at computing limits of piecewise functions and use of the Squeeze Theorem to compute some limits.

Infinite Limits - In this section we will look at limits that have a value of infinity or negative infinity. We'll also take a brief look at vertical asymptotes.

Limits At Infinity, Part I - In this section we will start looking at limits at infinity, *i.e.* limits in which the variable gets very large in either the positive or negative sense. We will concentrate on polynomials and rational expressions in this section. We'll also take a brief look at horizontal asymptotes.

Limits At Infinity, Part II - In this section we will continue covering limits at infinity. We'll be looking at exponentials, logarithms and inverse tangents in this section.

Continuity - In this section we will introduce the concept of continuity and how it relates to limits. We will also see the Intermediate Value Theorem in this section and how it can be used to determine if functions have solutions in a given interval.

The Definition of the Limit - In this section we will give a precise definition of several of the limits covered in this section. We will work several basic examples illustrating how to use this precise definition to compute a limit. We'll also give a precise definition of continuity.

Derivatives - In this chapter we will start looking at the next major topic in a calculus class, derivatives. This chapter is devoted almost exclusively to finding derivatives. We will be looking at one application of them in this chapter. We will be leaving most of the applications of derivatives to the next chapter.

The Definition of the Derivative - In this section we define the derivative, give various notations for the derivative and work a few problems illustrating how to use the definition of the derivative to actually compute the derivative of a function.

Interpretation of the Derivative - In this section we give several of the more important interpretations of the derivative. We discuss the rate of change of a function, the velocity of a moving object and the slope of the tangent line to a graph of a function.

Differentiation Formulas - In this section we give most of the general derivative formulas and properties used when taking the derivative of a function. Examples in this section concentrate mostly on polynomials, roots and more generally variables raised to powers.

Product and Quotient Rule - In this section we will give two of the more important formulas for differentiating functions. We will discuss the Product Rule and the Quotient Rule allowing us to differentiate functions that, up to this point, we were unable to differentiate.

Derivatives of Trig Functions - In this section we will discuss differentiating trig functions. Derivatives of all six trig functions are given and we show the derivation of the derivative of $\sin(x)$ and $\tan(x)$.

Derivatives of Exponential and Logarithm Functions - In this section we derive the formulas for the derivatives of the exponential and logarithm functions.

Derivatives of Inverse Trig Functions - In this section we give the derivatives of all six inverse trig functions. We show the derivation of the formulas for inverse sine, inverse cosine and inverse tangent.

Derivatives of Hyperbolic Functions - In this section we define the hyperbolic functions, give the relationships between them and some of the basic facts involving hyperbolic functions.

We also give the derivatives of each of the six hyperbolic functions and show the derivation of the formula for hyperbolic sine.

Chain Rule - In this section we discuss one of the more useful and important differentiation formulas, The Chain Rule. With the chain rule in hand we will be able to differentiate a much wider variety of functions. As you will see throughout the rest of your Calculus courses a great many of derivatives you take will involve the chain rule!

Implicit Differentiation - In this section we will discuss implicit differentiation. Not every function can be explicitly written in terms of the independent variable, e.g. $y = f(x)$ and yet we will still need to know what $f'(x)$ is. Implicit differentiation will allow us to find the derivative in these cases. Knowing implicit differentiation will allow us to do one of the more important applications of derivatives, Related Rates (the next section).

Related Rates - In this section we will discuss the only application of derivatives in this section, Related Rates. In related rates problems we are give the rate of change of one quantity in a problem and asked to determine the rate of one (or more) quantities in the problem. This is often one of the more difficult sections for students. We work quite a few problems in this section so hopefully by the end of this section you will get a decent understanding on how these problems work.

Higher Order Derivatives - In this section we define the concept of higher order derivatives and give a quick application of the second order derivative and show how implicit differentiation works for higher order derivatives.

Logarithmic Differentiation - In this section we will discuss logarithmic differentiation. Logarithmic differentiation gives an alternative method for differentiating products and quotients (sometimes easier than using product and quotient rule). More importantly, however, is the fact that logarithm differentiation allows us to differentiate functions that are in the form of one function raised to another function, *i.e.* there are variables in both the base and exponent of the function.

Derivative Applications - In the previous chapter we focused almost exclusively on the computation of derivatives. In this chapter will focus on applications of derivatives. It is important to always remember that we didn't spend a whole chapter talking about computing derivatives just to be talking about them. There are many very important applications to derivatives.

The two main applications that we'll be looking at in this chapter are using derivatives to determine information about graphs of functions and optimization problems. These will not be the only applications however. We will be revisiting limits and taking a look at an application of derivatives that will allow us to compute limits that we haven't been able to compute previously. We will also see how derivatives can be used to estimate solutions to equations.

Rates of Change - In this section we review the main application/interpretation of derivatives from the previous chapter (*i.e.* rates of change) that we will be using in many of the applications in this chapter.

Critical Points - In this section we give the definition of critical points. Critical points will show

up in most of the sections in this chapter, so it will be important to understand them and how to find them. We will work a number of examples illustrating how to find them for a wide variety of functions.

Minimum and Maximum Values - In this section we define absolute (or global) minimum and maximum values of a function and relative (or local) minimum and maximum values of a function. It is important to understand the difference between the two types of minimum/-maximum (collectively called extrema) values for many of the applications in this chapter and so we use a variety of examples to help with this. We also give the Extreme Value Theorem and Fermat's Theorem, both of which are very important in the many of the applications we'll see in this chapter.

Finding Absolute Extrema - In this section we discuss how to find the absolute (or global) minimum and maximum values of a function. In other words, we will be finding the largest and smallest values that a function will have.

The Shape of a Graph, Part I - In this section we will discuss what the first derivative of a function can tell us about the graph of a function. The first derivative will allow us to identify the relative (or local) minimum and maximum values of a function and where a function will be increasing and decreasing. We will also give the First Derivative test which will allow us to classify critical points as relative minimums, relative maximums or neither a minimum or a maximum.

The Shape of a Graph, Part II - In this section we will discuss what the second derivative of a function can tell us about the graph of a function. The second derivative will allow us to determine where the graph of a function is concave up and concave down. The second derivative will also allow us to identify any inflection points (i.e. where concavity changes) that a function may have. We will also give the Second Derivative Test that will give an alternative method for identifying some critical points (but not all) as relative minimums or relative maximums.

The Mean Value Theorem - In this section we will give Rolle's Theorem and the Mean Value Theorem. With the Mean Value Theorem we will prove a couple of very nice facts, one of which will be very useful in the next chapter.

Optimization Problems - In this section we will be determining the absolute minimum and/or maximum of a function that depends on two variables given some constraint, or relationship, that the two variables must always satisfy. We will discuss several methods for determining the absolute minimum or maximum of the function. Examples in this section tend to center around geometric objects such as squares, boxes, cylinders, etc.

More Optimization Problems - In this section we will continue working optimization problems. The examples in this section tend to be a little more involved and will often involve situations that will be more easily described with a sketch as opposed to the 'simple' geometric objects we looked at in the previous section.

L'Hospital's Rule and Indeterminate Forms - In this section we will revisit indeterminate forms and limits and take a look at L'Hospital's Rule. L'Hospital's Rule will allow us to evaluate some

limits we were not able to previously.

Linear Approximations - In this section we discuss using the derivative to compute a linear approximation to a function. We can use the linear approximation to a function to approximate values of the function at certain points. While it might not seem like a useful thing to do with when we have the function there really are reasons that one might want to do this. We give two ways this can be useful in the examples.

Differentials - In this section we will compute the differential for a function. We will give an application of differentials in this section. However, one of the more important uses of differentials will come in the next chapter and unfortunately we will not be able to discuss it until then.

Newton's Method - In this section we will discuss Newton's Method. Newton's Method is an application of derivatives that will allow us to approximate solutions to an equation. There are many equations that cannot be solved directly and with this method we can get approximations to the solutions to many of those equations.

Business Applications - In this section we will give a cursory discussion of some basic applications of derivatives to the business field. We will revisit finding the maximum and/or minimum function value and we will define the marginal cost function, the average cost, the revenue function, the marginal revenue function and the marginal profit function. Note that this section is only intended to introduce these concepts and not teach you everything about them.

Integrals In this chapter we will be looking at integrals. Integrals are the third and final major topic that will be covered in this class. As with derivatives this chapter will be devoted almost exclusively to finding and computing integrals. Applications will be given in the following chapter. There are really two types of integrals that we'll be looking at in this chapter : Indefinite Integrals and Definite Integrals. The first half of this chapter is devoted to indefinite integrals and the last half is devoted to definite integrals. As we will see in the last half of the chapter if we don't know indefinite integrals we will not be able to do definite integrals.

Indefinite Integrals - In this section we will start off the chapter with the definition and properties of indefinite integrals. We will not be computing many indefinite integrals in this section. This section is devoted to simply defining what an indefinite integral is and to give many of the properties of the indefinite integral. Actually computing indefinite integrals will start in the next section.

Computing Indefinite Integrals - In this section we will compute some indefinite integrals. The integrals in this section will tend to be those that do not require a lot of manipulation of the function we are integrating in order to actually compute the integral. As we will see starting in the next section many integrals do require some manipulation of the function before we can actually do the integral. We will also take a quick look at an application of indefinite integrals.

Substitution Rule for Indefinite Integrals - In this section we will start using one of the more common and useful integration techniques - The Substitution Rule. With the substitution

rule we will be able integrate a wider variety of functions. The integrals in this section will all require some manipulation of the function prior to integrating unlike most of the integrals from the previous section where all we really needed were the basic integration formulas.

More Substitution Rule - In this section we will continue to look at the substitution rule. The problems in this section will tend to be a little more involved than those in the previous section.

Area Problem - In this section we start off with the motivation for definite integrals and give one of the interpretations of definite integrals. We will be approximating the amount of area that lies between a function and the x -axis. As we will see in the next section this problem will lead us to the definition of the definite integral and will be one of the main interpretations of the definite integral that we'll be looking at in this material.

Definition of the Definite Integral - In this section we will formally define the definite integral, give many of its properties and discuss a couple of interpretations of the definite integral. We will also look at the first part of the Fundamental Theorem of Calculus which shows the very close relationship between derivatives and integrals

Computing Definite Integrals - In this section we will take a look at the second part of the Fundamental Theorem of Calculus. This will show us how we compute definite integrals without using (the often very unpleasant) definition. The examples in this section can all be done with a basic knowledge of indefinite integrals and will not require the use of the substitution rule. Included in the examples in this section are computing definite integrals of piecewise and absolute value functions.

Substitution Rule for Definite Integrals - In this section we will revisit the substitution rule as it applies to definite integrals. The only real requirements to being able to do the examples in this section are being able to do the substitution rule for indefinite integrals and understanding how to compute definite integrals in general.

Applications of Integrals In this last chapter of this course we will be taking a look at a couple of Applications of Integrals. There are many other applications, however many of them require integration techniques that are typically taught in Calculus II. We will therefore be focusing on applications that can be done only with knowledge taught in this course.

Because this chapter is focused on the applications of integrals it is assumed in all the examples that you are capable of doing the integrals. There will not be as much detail in the integration process in the examples in this chapter as there was in the examples in the previous chapter.

Average Function Value - In this section we will look at using definite integrals to determine the average value of a function on an interval. We will also give the Mean Value Theorem for Integrals.

Area Between Curves - In this section we'll take a look at one of the main applications of definite integrals in this chapter. We will determine the area of the region bounded by two curves.

Volumes of Solids of Revolution / Method of Rings - In this section, the first of two sections

devoted to finding the volume of a solid of revolution, we will look at the method of rings/disks to find the volume of the object we get by rotating a region bounded by two curves (one of which may be the x or y -axis) around a vertical or horizontal axis of rotation.

Volumes of Solids of Revolution / Method of Cylinders - In this section, the second of two sections devoted to finding the volume of a solid of revolution, we will look at the method of cylinders/shells to find the volume of the object we get by rotating a region bounded by two curves (one of which may be the x or y -axis) around a vertical or horizontal axis of rotation.

More Volume Problems - In the previous two sections we looked at solids that could be found by treating them as a solid of revolution. Not all solids can be thought of as solids of revolution and, in fact, not all solids of revolution can be easily dealt with using the methods from the previous two sections. So, in this section we'll take a look at finding the volume of some solids that are either not solids of revolutions or are not easy to do as a solid of revolution.

Work - In this section we will look at is determining the amount of work required to move an object subject to a force over a given distance.

Integration Techniques In this chapter we are going to be looking at various integration techniques. There are a fair number of them and some will be easier than others. The point of the chapter is to teach you these new techniques and so this chapter assumes that you've got a fairly good working knowledge of basic integration as well as substitutions with integrals. In fact, most integrals involving "simple" substitutions will not have any of the substitution work shown. It is going to be assumed that you can verify the substitution portion of the integration yourself.

Also, most of the integrals done in this chapter will be indefinite integrals. It is also assumed that once you can do the indefinite integrals you can also do the definite integrals and so to conserve space we concentrate mostly on indefinite integrals. There is one exception to this and that is the Trig Substitution section and in this case there are some subtleties involved with definite integrals that we're going to have to watch out for. Outside of that however, most sections will have at most one definite integral example and some sections will not have any definite integral examples.

Integration by Parts - In this section we will be looking at Integration by Parts. Of all the techniques we'll be looking at in this class this is the technique that students are most likely to run into down the road in other classes. We also give a derivation of the integration by parts formula.

Integrals Involving Trig Functions - In this section we look at integrals that involve trig functions. In particular we concentrate integrating products of sines and cosines as well as products of secants and tangents. We will also briefly look at how to modify the work for products of these trig functions for some quotients of trig functions.

Trig Substitutions - In this section we will look at integrals (both indefinite and definite) that require the use of a substitutions involving trig functions and how they can be used to simplify certain integrals.

Partial Fractions - In this section we will use partial fractions to rewrite integrands into a form

that will allow us to do integrals involving some rational functions.

Integrals Involving Roots - In this section we will take a look at a substitution that can, on occasion, be used with integrals involving roots.

Integrals Involving Quadratics - In this section we are going to look at some integrals that involve quadratics for which the previous techniques won't work right away. In some cases, manipulation of the quadratic needs to be done before we can do the integral. We will see several cases where this is needed in this section.

Integration Strategy - In this section we give a general set of guidelines for determining how to evaluate an integral. The guidelines given here involve a mix of both Calculus I and Calculus II techniques to be as general as possible. Also note that there really isn't one set of guidelines that will always work and so you always need to be flexible in following this set of guidelines.

Improper Integrals - In this section we will look at integrals with infinite intervals of integration and integrals with discontinuous integrands in this section. Collectively, they are called improper integrals and as we will see they may or may not have a finite (i.e. not infinite) value. Determining if they have finite values will, in fact, be one of the major topics of this section.

Comparison Test for Improper Integrals - It will not always be possible to evaluate improper integrals and yet we still need to determine if they converge or diverge (i.e. if they have a finite value or not). So, in this section we will use the Comparison Test to determine if improper integrals converge or diverge.

Approximating Definite Integrals - In this section we will look at several fairly simple methods of approximating the value of a definite integral. It is not possible to evaluate every definite integral (i.e. because it is not possible to do the indefinite integral) and yet we may need to know the value of the definite integral anyway. These methods allow us to at least get an approximate value which may be enough in a lot of cases.

More Applications of Integrals In this section we're going to take a look at some of the Applications of Integrals. It should be noted as well that these applications are presented here, as opposed to Calculus I, simply because many of the integrals that arise from these applications tend to require techniques that we discussed in the previous chapter.

Arc Length - In this section we'll determine the length of a curve over a given interval.

Surface Area - In this section we'll determine the surface area of a solid of revolution, *i.e.* a solid obtained by rotating a region bounded by two curves about a vertical or horizontal axis.

Center of Mass - In this section we will determine the center of mass or centroid of a thin plate where the plate can be described as a region bounded by two curves (one of which may be the x or y -axis).

Hydrostatic Pressure and Force - In this section we'll determine the hydrostatic pressure

and force on a vertical plate submerged in water. The plates used in the examples can all be described as regions bounded by one or more curves/lines.

Probability - Many quantities can be described with probability density functions. For example, the length of time a person waits in line at a checkout counter or the life span of a light bulb. None of these quantities are fixed values and will depend on a variety of factors. In this section we will look at probability density functions and computing the mean (think average wait in line or average life span of a light bulb) of a probability density function.

Parametric Equations and Polar Coordinates In this section we will be looking at parametric equations and polar coordinates. While the two subjects don't appear to have that much in common on the surface we will see that several of the topics in polar coordinates can be done in terms of parametric equations and so in that sense they make a good match in this chapter

We will also be looking at how to do many of the standard calculus topics such as tangents and area in terms of parametric equations and polar coordinates.

Parametric Equations and Curves - In this section we will introduce parametric equations and parametric curves (i.e. graphs of parametric equations). We will graph several sets of parametric equations and discuss how to eliminate the parameter to get an algebraic equation which will often help with the graphing process.

Tangents with Parametric Equations - In this section we will discuss how to find the derivatives $\frac{dy}{dx}$ and $\frac{d^2y}{dx^2}$ for parametric curves. We will also discuss using these derivative formulas to find the tangent line for parametric curves as well as determining where a parametric curve is increasing/decreasing and concave up/concave down.

Area with Parametric Equations - In this section we will discuss how to find the area between a parametric curve and the x -axis using only the parametric equations (rather than eliminating the parameter and using standard Calculus I techniques on the resulting algebraic equation).

Arc Length with Parametric Equations - In this section we will discuss how to find the arc length of a parametric curve using only the parametric equations (rather than eliminating the parameter and using standard Calculus techniques on the resulting algebraic equation).

Surface Area with Parametric Equations - In this section we will discuss how to find the surface area of a solid obtained by rotating a parametric curve about the x or y -axis using only the parametric equations (rather than eliminating the parameter and using standard Calculus techniques on the resulting algebraic equation).

Polar Coordinates - In this section we will introduce polar coordinates an alternative coordinate system to the 'normal' Cartesian/Rectangular coordinate system. We will derive formulas to convert between polar and Cartesian coordinate systems. We will also look at many of the standard polar graphs as well as circles and some equations of lines in terms of polar coordinates.

Tangents with Polar Coordinates - In this section we will discuss how to find the derivative $\frac{dy}{dx}$

for polar curves. We will also discuss using this derivative formula to find the tangent line for polar curves using only polar coordinates (rather than converting to Cartesian coordinates and using standard Calculus techniques).

Area with Polar Coordinates - In this section we will discuss how to the area enclosed by a polar curve. The regions we look at in this section tend (although not always) to be shaped vaguely like a piece of pie or pizza and we are looking for the area of the region from the outer boundary (defined by the polar equation) and the origin/pole. We will also discuss finding the area between two polar curves.

Arc Length with Polar Coordinates - In this section we will discuss how to find the arc length of a polar curve using only polar coordinates (rather than converting to Cartesian coordinates and using standard Calculus techniques).

Surface Area with Polar Coordinates - In this section we will discuss how to find the surface area of a solid obtained by rotating a polar curve about the x or y -axis using only polar coordinates (rather than converting to Cartesian coordinates and using standard Calculus techniques).

Arc Length and Surface Area Revisited - In this section we will summarize all the arc length and surface area formulas we developed over the course of the last two chapters.

Series and Sequences In this chapter we'll be taking a look at sequences and (infinite) series. In fact, this chapter will deal almost exclusively with series. However, we also need to understand some of the basics of sequences in order to properly deal with series. We will therefore, spend a little time on sequences as well.

Series is one of those topics that many students don't find all that useful. To be honest, many students will never see series outside of their calculus class. However, series do play an important role in the field of ordinary differential equations and without series large portions of the field of partial differential equations would not be possible.

In other words, series is an important topic even if you won't ever see any of the applications. Most of the applications are beyond the scope of most Calculus courses and tend to occur in classes that many students don't take. So, as you go through this material keep in mind that these do have applications even if we won't really be covering many of them in this class.

Sequences - In this section we define just what we mean by sequence in a math class and give the basic notation we will use with them. We will focus on the basic terminology, limits of sequences and convergence of sequences in this section. We will also give many of the basic facts and properties we'll need as we work with sequences.

More on Sequences - In this section we will continue examining sequences. We will determine if a sequence is an increasing sequence or a decreasing sequence and hence if it is a monotonic sequence. We will also determine a sequence is bounded below, bounded above and/or bounded.

Series - The Basics - In this section we will formally define an infinite series. We will also give many of the basic facts, properties and ways we can use to manipulate a series. We

will also briefly discuss how to determine if an infinite series will converge or diverge (a more in depth discussion of this topic will occur in the next section).

Convergence/Divergence of Series - In this section we will discuss in greater detail the convergence and divergence of infinite series. We will illustrate how partial sums are used to determine if an infinite series converges or diverges. We will also give the Divergence Test for series in this section.

Special Series - In this section we will look at three series that either show up regularly or have some nice properties that we wish to discuss. We will examine Geometric Series, Telescoping Series, and Harmonic Series.

Integral Test - In this section we will discuss using the Integral Test to determine if an infinite series converges or diverges. The Integral Test can be used on an infinite series provided the terms of the series are positive and decreasing. A proof of the Integral Test is also given.

Comparison Test/Limit Comparison Test - In this section we will discuss using the Comparison Test and Limit Comparison Tests to determine if an infinite series converges or diverges. In order to use either test the terms of the infinite series must be positive. Proofs for both tests are also given.

Alternating Series Test - In this section we will discuss using the Alternating Series Test to determine if an infinite series converges or diverges. The Alternating Series Test can be used only if the terms of the series alternate in sign. A proof of the Alternating Series Test is also given.

Absolute Convergence - In this section we will have a brief discussion on absolute convergence and conditionally convergent and how they relate to convergence of infinite series.

Ratio Test - In this section we will discuss using the Ratio Test to determine if an infinite series converges absolutely or diverges. The Ratio Test can be used on any series, but unfortunately will not always yield a conclusive answer as to whether a series will converge absolutely or diverge. A proof of the Ratio Test is also given.

Root Test - In this section we will discuss using the Root Test to determine if an infinite series converges absolutely or diverges. The Root Test can be used on any series, but unfortunately will not always yield a conclusive answer as to whether a series will converge absolutely or diverge. A proof of the Root Test is also given.

Strategy for Series - In this section we give a general set of guidelines for determining which test to use in determining if an infinite series will converge or diverge. Note as well that there really isn't one set of guidelines that will always work and so you always need to be flexible in following this set of guidelines. A summary of all the various tests, as well as conditions that must be met to use them, we discussed in this chapter are also given in this section.

Estimating the Value of a Series - In this section we will discuss how the Integral Test, Comparison Test, Alternating Series Test and the Ratio Test can, on occasion, be used to esti-

mating the value of an infinite series.

Power Series - In this section we will give the definition of the power series as well as the definition of the radius of convergence and interval of convergence for a power series. We will also illustrate how the Ratio Test and Root Test can be used to determine the radius and interval of convergence for a power series.

Power Series and Functions - In this section we discuss how the formula for a convergent Geometric Series can be used to represent some functions as power series. To use the Geometric Series formula, the function must be able to be put into a specific form, which is often impossible. However, use of this formula does quickly illustrate how functions can be represented as a power series. We also discuss differentiation and integration of power series.

Taylor Series - In this section we will discuss how to find the Taylor/Maclaurin Series for a function. This will work for a much wider variety of function than the method discussed in the previous section at the expense of some often unpleasant work. We also derive some well known formulas for Taylor series of e^x , $\cos(x)$ and $\sin(x)$ around $x = 0$.

Applications of Series - In this section we will take a quick look at a couple of applications of series. We will illustrate how we can find a series representation for indefinite integrals that cannot be evaluated by any other method. We will also see how we can use the first few terms of a power series to approximate a function.

Binomial Series - In this section we will give the Binomial Theorem and illustrate how it can be used to quickly expand terms in the form $(a + b)^n$ when n is an integer. In addition, when n is not an integer an extension to the Binomial Theorem can be used to give a power series representation of the term.

Vectors This is a fairly short chapter. We will be taking a brief look at vectors and some of their properties. We will need some of this material in the next chapter and those of you heading on towards Calculus III will use a fair amount of this there as well.

Basic Concepts - In this section we will introduce some common notation for vectors as well as some of the basic concepts about vectors such as the magnitude of a vector and unit vectors. We also illustrate how to find a vector from its starting and end points.

Vector Arithmetic - In this section we will discuss the mathematical and geometric interpretation of the sum and difference of two vectors. We also define and give a geometric interpretation for scalar multiplication. We also give some of the basic properties of vector arithmetic and introduce the common i, j, k notation for vectors.

Dot Product - In this section we will define the dot product of two vectors. We give some of the basic properties of dot products and define orthogonal vectors and show how to use the dot product to determine if two vectors are orthogonal. We also discuss finding vector projections and direction cosines in this section.

Cross Product - In this section we define the cross product of two vectors and give some of the basic facts and properties of cross products.

Three Dimensional Space In this chapter we will start taking a more detailed look at three dimensional space (3-D space or \mathbb{R}^3). This is a very important topic for Calculus III since a good portion of Calculus III is done in three (or higher) dimensional space.

We will be looking at the equations of graphs in 3-D space as well as vector valued functions and how we do calculus with them. We will also be taking a look at a couple of new coordinate systems for 3-D space.

This is the only chapter that exists in two places in the notes. When we originally wrote these notes all of these topics were covered in Calculus II however, we have since moved several of them into Calculus III. So, rather than split the chapter up we kept it in the Calculus II notes and also put a copy in the Calculus III notes. Many of the sections not covered in Calculus III will be used on occasion there anyway and so they serve as a quick reference for when we need them. In addition this allows those that teach the topic in either place to have the notes quickly available to them.

The 3-D Coordinate System - In this section we will introduce the standard three dimensional coordinate system as well as some common notation and concepts needed to work in three dimensions.

Equations of Lines - In this section we will derive the vector form and parametric form for the equation of lines in three dimensional space. We will also give the symmetric equations of lines in three dimensional space. Note as well that while these forms can also be useful for lines in two dimensional space.

Equations of Planes - In this section we will derive the vector and scalar equation of a plane. We also show how to write the equation of a plane from three points that lie in the plane.

Quadric Surfaces - In this section we will be looking at some examples of quadric surfaces. Some examples of quadric surfaces are cones, cylinders, ellipsoids, and elliptic paraboloids.

Functions of Several Variables - In this section we will give a quick review of some important topics about functions of several variables. In particular we will discuss finding the domain of a function of several variables as well as level curves, level surfaces and traces.

Vector Functions - In this section we introduce the concept of vector functions concentrating primarily on curves in three dimensional space. We will however, touch briefly on surfaces as well. We will illustrate how to find the domain of a vector function and how to graph a vector function. We will also show a simple relationship between vector functions and parametric equations that will be very useful at times.

Calculus with Vector Functions - In this section here we discuss how to do basic calculus, i.e. limits, derivatives and integrals, with vector functions.

Tangent, Normal and Binormal Vectors - In this section we will define the tangent, normal and binormal vectors.

Arc Length with Vector Functions - In this section we will extend the arc length formula we

used early in the material to include finding the arc length of a vector function. As we will see the new formula really is just an almost natural extension of one we've already seen.

Curvature - In this section we give two formulas for computing the curvature (*i.e.* how fast the function is changing at a given point) of a vector function.

Velocity and Acceleration - In this section we will revisit a standard application of derivatives, the velocity and acceleration of an object whose position function is given by a vector function. For the acceleration we give formulas for both the normal acceleration and the tangential acceleration.

Cylindrical Coordinates - In this section we will define the cylindrical coordinate system, an alternate coordinate system for the three dimensional coordinate system. As we will see cylindrical coordinates are really nothing more than a very natural extension of polar coordinates into a three dimensional setting.

Spherical Coordinates - In this section we will define the spherical coordinate system, yet another alternate coordinate system for the three dimensional coordinate system. This coordinates system is very useful for dealing with spherical objects. We will derive formulas to convert between cylindrical coordinates and spherical coordinates as well as between Cartesian and spherical coordinates (the more useful of the two).

Partial Derivatives In Calculus I and in most of Calculus II we concentrated on functions of one variable. In Calculus III we will extend our knowledge of calculus into functions of two or more variables. Despite the fact that this chapter is about derivatives we will start out the chapter with a section on limits of functions of more than one variable. In the remainder of this chapter we will be looking at differentiating functions of more than one variable. As we will see, while there are differences with derivatives of functions of one variable, if you can do derivatives of functions of one variable you shouldn't have any problems differentiating functions of more than one variable. You'll just need to keep one subtlety in mind as we do the work.

Limits - In the section we'll take a quick look at evaluating limits of functions of several variables. We will also see a fairly quick method that can be used, on occasion, for showing that some limits do not exist.

Partial Derivatives - In this section we will look at the idea of partial derivatives. We will give the formal definition of the partial derivative as well as the standard notations and how to compute them in practice (*i.e.* without the use of the definition). As you will see if you can do derivatives of functions of one variable you won't have much of an issue with partial derivatives. There is only one (very important) subtlety that you need to always keep in mind while computing partial derivatives.

Interpretations of Partial Derivatives - In the section we will take a look at a couple of important interpretations of partial derivatives. First, the always important, rate of change of the function. Although we now have multiple 'directions' in which the function can change (unlike in Calculus I). We will also see that partial derivatives give the slope of tangent lines to the traces of the function.

Higher Order Partial Derivatives - In the section we will take a look at higher order partial derivatives. Unlike Calculus I however, we will have multiple second order derivatives, multiple third order derivatives, etc. because we are now working with functions of multiple variables. We will also discuss Clairaut's Theorem to help with some of the work in finding higher order derivatives.

Differentials - In this section we extend the idea of differentials we first saw in Calculus I to functions of several variables.

Chain Rule - In the section we extend the idea of the chain rule to functions of several variables. In particular, we will see that there are multiple variants to the chain rule here all depending on how many variables our function is dependent on and how each of those variables can, in turn, be written in terms of different variables. We will also give a nice method for writing down the chain rule for pretty much any situation you might run into when dealing with functions of multiple variables. In addition, we will derive a very quick way of doing implicit differentiation so we no longer need to go through the process we first did back in Calculus I.

Directional Derivatives - In the section we introduce the concept of directional derivatives. With directional derivatives we can now ask how a function is changing if we allow all the independent variables to change rather than holding all but one constant as we had to do with partial derivatives. In addition, we will define the gradient vector to help with some of the notation and work here. The gradient vector will be very useful in some later sections as well. We will also give a nice fact that will allow us to determine the direction in which a given function is changing the fastest.

Line Integrals In this section we are going to start looking at Calculus with vector fields (which we'll define in the first section). In particular we will be looking at a new type of integral, the line integral and some of the interpretations of the line integral. We will also take a look at one of the more important theorems involving line integrals, Green's Theorem.

Vector Fields - In this section we introduce the concept of a vector field and give several examples of graphing them. We also revisit the gradient that we first saw a few chapters ago.

Line Integrals - Part I - In this section we will start off with a quick review of parameterizing curves. This is a skill that will be required in a great many of the line integrals we evaluate and so needs to be understood. We will then formally define the first kind of line integral we will be looking at : line integrals with respect to arc length..

Line Integrals - Part II - In this section we will continue looking at line integrals and define the second kind of line integral we'll be looking at : line integrals with respect to x , y , and/or z . We also introduce an alternate form of notation for this kind of line integral that will be useful on occasion.

Line Integrals of Vector Fields - In this section we will define the third type of line integrals we'll be looking at : line integrals of vector fields. We will also see that this particular kind of line integral is related to special cases of the line integrals with respect to x , y and z .

Fundamental Theorem for Line Integrals - In this section we will give the fundamental theorem of calculus for line integrals of vector fields. This will illustrate that certain kinds of line integrals can be very quickly computed. We will also give quite a few definitions and facts that will be useful.

Conservative Vector Fields - In this section we will take a more detailed look at conservative vector fields than we've done in previous sections. We will also discuss how to find potential functions for conservative vector fields.

Green's Theorem - In this section we will discuss Green's Theorem as well as an interesting application of Green's Theorem that we can use to find the area of a two dimensional region.

Surface Integrals In the previous chapter we looked at evaluating integrals of functions or vector fields where the points came from a curve in two- or three-dimensional space. We now want to extend this idea and integrate functions and vector fields where the points come from a surface in three-dimensional space. These integrals are called surface integrals.

Curl and Divergence - In this section we will introduce the concepts of the curl and the divergence of a vector field. We will also give two vector forms of Green's Theorem and show how the curl can be used to identify if a three dimensional vector field is conservative field or not.

Parametric Surfaces - In this section we will take a look at the basics of representing a surface with parametric equations. We will also see how the parameterization of a surface can be used to find a normal vector for the surface (which will be very useful in a couple of sections) and how the parameterization can be used to find the surface area of a surface.

Surface Integrals - In this section we introduce the idea of a surface integral. With surface integrals we will be integrating over the surface of a solid. In other words, the variables will always be on the surface of the solid and will never come from inside the solid itself. Also, in this section we will be working with the first kind of surface integrals we'll be looking at in this chapter : surface integrals of functions.

Surface Integrals of Vector Fields - In this section we will introduce the concept of an oriented surface and look at the second kind of surface integral we'll be looking at : surface integrals of vector fields.

Stokes' Theorem - In this section we will discuss Stokes' Theorem.

Divergence Theorem - In this section we will discuss the Divergence Theorem.

1 Review

Technically a student coming into a Calculus class is supposed to know both Algebra and Trigonometry. Unfortunately, the reality is often much different. Most students enter a Calculus class woefully unprepared for both the algebra and the trig that is in a Calculus class. This is very unfortunate since good algebra skills are absolutely vital to successfully completing any Calculus course and if your Calculus course includes trig (as this one does) good trig skills are also important in many sections.

The above statement is not meant to denigrate your favorite Algebra or Trig instructor. It is simply an acknowledgment of the fact that many of these courses, especially Algebra courses, are aimed at a more general audience and so do not always put the time into topics that are vital to a Calculus course and/or the level of difficulty is kept lower than might be best for students heading on towards Calculus.

Far too often the biggest impediment to students being successful in a Calculus course is they do not have sufficient skills in the underlying algebra and trig that will be in many of the calculus problems we'll be looking at. These students end up struggling with the algebra and trig in the problems rather than working to understand the calculus topics which in turn negatively impacts their grade in a Calculus course. The intent of this chapter, therefore, is to do a very cursory review of some algebra and trig skills that are vital to a calculus course that many students just didn't learn as well as they should have from their Algebra and Trig courses.

This chapter does not include all the algebra and trig skills that are needed to be successful in a Calculus course. It only includes those topics that most students are particularly deficient in. For instance, factoring is also vital to completing a standard calculus class but is not included here as it is assumed that if you are taking a Calculus course then you do know how to factor. Likewise, it is assumed that if you are taking a Calculus course then you know how to solve linear and quadratic equations so those topics are not covered here either. For a more in depth review of Algebra topics you should check out the full set of Algebra notes at <http://tutorial.math.lamar.edu>.

Note that even though these topics are very important to a Calculus class we rarely cover all of them in the actual class itself. We simply don't have the time to do that. We will cover certain portions of this chapter in class, but for the most part we leave it to the students to read this chapter on their own to make sure they are ready for these topics as they arise in class.

The following sections are the assignment problems (no solutions available) for this material.

If you are looking for some practice problems (with solutions available) please check out the [Practice Problems](#). There you will find a set of problems that should give you quite a bit practice.

1.1 Functions

For problems 1 - 6 the given functions perform the indicated function evaluations.

1. $f(x) = 10x - 3$

(a) $f(-5)$

(b) $f(0)$

(c) $f(7)$

(d) $f(t^2 + 2)$

(e) $f(12 - x)$

(f) $f(x + h)$

2. $h(y) = 4y^2 - 7y + 1$

(a) $h(0)$

(b) $h(-3)$

(c) $h(5)$

(d) $h(6z)$

(e) $h(1 - 3y)$

(f) $h(y + k)$

3. $g(t) = \frac{t + 5}{1 - t}$

(a) $g(0)$

(b) $g(4)$

(c) $g(-7)$

(d) $g(x^2 - 5)$

(e) $g(t + h)$

(f) $g(4\sqrt{t} + 9)$

4. $f(z) = \sqrt{4z + 5}$

(a) $f(0)$

(b) $f(-1)$

(c) $f(-2)$

(d) $h(5 - 12y)$

(e) $f(2z^2 + 8)$

(f) $f(z + h)$

5. $z(x) = \frac{\sqrt{x^2 + 9}}{4x + 8}$

(a) $z(4)$

(b) $z(-4)$

(c) $z(1)$

(d) $z(2 - 7x)$

(e) $z(\sqrt{3x + 4})$

(f) $z(x + h)$

6. $Y(t) = \sqrt{3 - t} - \frac{t}{2t + 5}$

(a) $Y(0)$

(b) $Y(7)$

(c) $Y(-4)$

(d) $Y(5 - t)$

(e) $Y(t^2 - 10)$

(f) $Y(6t - t^2)$

Difference Quotient

The **difference quotient** of a function $f(x)$ is defined to be,

$$\frac{f(x+h) - f(x)}{h}$$

For problems 7 - 13 compute the difference quotient of the given function.

7. $Q(t) = 4 - 7t$

8. $g(t) = 42$

9. $H(x) = 2x^2 + 9$

10. $z(y) = 3 - 8y - y^2$

11. $g(z) = \sqrt{4 + 3z}$

12. $y(x) = \frac{-4}{1 - 2x}$

13. $f(t) = \frac{t^2}{t + 7}$

For problems 14 - 21 determine all the roots of the given function.

14. $y(t) = 40 + 3t - t^2$

15. $f(x) = 6x^4 - 5x^3 - 4x^2$

16. $Z(p) = 6 - 11p - p^2$

17. $h(y) = 4y^6 + 10y^5 + y^4$

18. $g(z) = z^7 + 6z^4 - 16z$

19. $f(t) = t^{\frac{1}{2}} - 8t^{\frac{1}{4}} + 15$

20. $h(w) = \frac{w}{4w + 5} + \frac{3w}{w - 8}$

21. $g(w) = \frac{w}{w + 3} - \frac{w + 2}{4w - 1}$

For problems 22 - 30 find the domain and range of the given function.

22. $f(x) = x^2 - 8x + 3$

23. $z(w) = 4 - 7w - w^2$

24. $g(t) = 3t^2 + 2t - 3$

25. $g(x) = 5 - \sqrt{2x}$

26. $B(z) = 10 + \sqrt{9 + 7z^2}$

27. $h(y) = 1 + \sqrt{6 - 7y}$

28. $f(x) = 12 - 5\sqrt{2x + 9}$

29. $V(t) = -6|5 - t|$

30. $y(x) = 12 + 9|x^2 - 1|$

For problems 31 - 51 find the domain of the given function.

31. $f(t) = \frac{4 - 12t + 8t^2}{16t + 9}$

32. $v(y) = \frac{y^3 - 27}{4 - 17y}$

33. $g(x) = \frac{3x + 1}{5x^2 - 3x - 2}$

34. $h(t) = \frac{t^3 - t^2 + 1 - 1}{35t^3 + 2t^4 - t^5}$

35. $f(z) = \frac{z^2 + z}{z^3 - 9z^2 + 2z}$

36. $V(p) = \frac{3 - p^4}{4p^2 + 10p + 2}$

37. $g(z) = \sqrt{z^2 - 15}$

38. $f(t) = \sqrt{36 - 9t^2}$

39. $A(x) = \sqrt{15x - 2x^2 - x^3}$

40. $Q(y) = \sqrt{4y^3 - 4y^2 + y}$

41. $P(t) = \frac{t^2 + 7}{\sqrt{6t - t^2}}$

42.
$$h(t) = \frac{t^2}{\sqrt{5 + 3t - t^2}}$$

43.
$$h(x) = \frac{6}{\sqrt{x^2 - 7x + 3}}$$

44.
$$f(z) = \frac{z + 1}{\sqrt{z^4 - 6z^3 + 9z^2}}$$

45.
$$S(t) = \sqrt{8 - t} + \sqrt{2t}$$

46.
$$g(x) = \sqrt{5x - 8} - 2\sqrt{x + 9}$$

47.
$$h(y) = \sqrt{49 - y^2} - \frac{y}{\sqrt{4y - 12}}$$

48.
$$A(x) = \frac{x + 1}{x - 4} + 4\sqrt{x^2 + 10x + 9}$$

49.
$$f(t) = \frac{8}{t^2 - 3t - 4} + \frac{3}{\sqrt{12 - 7t - 3t^2}}$$

50.
$$R(x) = \frac{3}{x^4 + x^2} + \sqrt[5]{x^2 - x - 6}$$

51.
$$C(z) = z^3 - \sqrt[4]{z^6 + z^2}$$

For problems 52 - 55 compute $(f \circ g)(x)$ and $(g \circ f)(x)$ for each given pair of functions.

52.
$$f(x) = 5 + 2x, g(x) = 8 - 23x$$

53.
$$f(x) = \sqrt{2 - x}, g(x) = 2x^2 - 9$$

54.
$$f(x) = 2x^2 + x - 4, g(x) = 7x - x^2$$

55.
$$f(x) = \frac{x}{3 + 2x}, g(x) = 8 + 5x$$

1.2 Inverse Functions

For each of the following functions find the inverse of the function. Verify your inverse by computing one or both of the composition as discussed in this section.

1. $f(x) = 11x - 8$

2. $g(x) = 4 - 10x$

3. $Z(x) = 2x^7 - 9$

4. $h(x) = 7 + (2x + 1)^3$

5. $W(x) = \sqrt[3]{15x + 2}$

6. $h(x) = \sqrt[3]{6 - 18x}$

7. $R(x) = \frac{2x + 14}{6x + 1}$

8. $g(x) = \frac{1 - x}{9 - 12x}$

1.3 Trig Functions

Determine the exact value of each of the following without using a calculator.

Note that the point of these problems is not really to learn how to find the value of trig functions but instead to get you comfortable with the unit circle since that is a very important skill that will be needed in solving trig equations.

1. $\tan\left(\frac{3\pi}{4}\right)$

2. $\sin\left(\frac{7\pi}{6}\right)$

3. $\sin\left(-\frac{3\pi}{4}\right)$

4. $\cos\left(\frac{4\pi}{3}\right)$

5. $\cot\left(\frac{5\pi}{4}\right)$

6. $\sin\left(-\frac{5\pi}{6}\right)$

7. $\sec\left(-\frac{\pi}{6}\right)$

8. $\cos\left(\frac{5\pi}{4}\right)$

9. $\cos\left(\frac{11\pi}{6}\right)$

10. $\csc\left(\frac{11\pi}{6}\right)$

11. $\cot\left(-\frac{4\pi}{3}\right)$

12. $\cos\left(-\frac{\pi}{4}\right)$

13. $\csc\left(\frac{2\pi}{3}\right)$

14. $\sec\left(\frac{17\pi}{6}\right)$

15. $\sin\left(-\frac{23\pi}{3}\right)$

16. $\tan\left(\frac{31\pi}{6}\right)$

17. $\cos\left(-\frac{15\pi}{4}\right)$

18. $\sec\left(-\frac{23\pi}{4}\right)$

19. $\cot\left(\frac{11\pi}{4}\right)$

1.4 Solving Trig Equations

Without using a calculator find the solution(s) to the following equations. If an interval is given find only those solutions that are in the interval. If no interval is given find all solutions to the equation.

1. $10 \cos(8t) = -5$
2. $10 \cos(8t) = -5$ in $\left[-\frac{\pi}{4}, \frac{\pi}{4}\right]$
3. $2 \sin\left(\frac{z}{4}\right) = \sqrt{3}$
4. $2 \sin\left(\frac{z}{4}\right) = \sqrt{3}$ in $[0, 16\pi]$
5. $2 \sin\left(\frac{2t}{3}\right) + \sqrt{2} = 0$ in $[0, 5\pi]$
6. $\sqrt{6} = -\sqrt{8} \cos(3x)$ in $\left[0, \frac{5\pi}{3}\right]$
7. $10 + 7 \tan(4x) = 3$ in $[-\pi, 0]$
8. $0 = 2 \cos\left(\frac{y}{2}\right) - \sqrt{2}$ in $[-4\pi, 5\pi]$
9. $3 \cos(5z) - 1 = 7$ in $[-\pi, \pi]$
10. $7\sqrt{3} + 7 \cot(2w) = 0$ in $\left[\frac{\pi}{3}, 2\pi\right]$
11. $2 \csc\left(\frac{x}{3}\right) + \sqrt{8} = 0$ in $[0, 2\pi]$
12. $3 - 4 \sin(4t) = 5$ in $\left[-\frac{3\pi}{2}, -\frac{\pi}{2}\right]$
13. $3 \sec\left(\frac{y}{5}\right) + 9 = 15$ in $[-3\pi, 20\pi]$
14. $\sqrt{12} \cos(2z) - 2 \sin(2z) = 0$ in $\left[\frac{3\pi}{2}, 2\pi\right]$

1.5 Solving Trig Equations with Calculators, Part I

Find the solution(s) to the following equations. If an interval is given find only those solutions that are in the interval. If no interval is given find all solutions to the equation.

1. $2 - 14 \sin\left(\frac{t}{3}\right) = 5$

2. $4 \cos(4x) + 8 = 10 - \cos(4x)$

3. $2 \tan(3w) + 3 = 25$

4. $2 \sin\left(\frac{3x}{5}\right) - \frac{7}{5} = \frac{1}{5}$ in $[0, 15]$

5. $1 = 3 + 8 \cos\left(\frac{w}{2}\right)$ in $[-20, 5]$

6. $45 \sin\left(\frac{x}{2}\right) - 9 = 7 \sin\left(\frac{x}{2}\right) + 17$ in $[-10, 20]$

7. $\frac{2}{3} = 4 - 3 \sec(11x)$ in $[0, 1]$

8. $3 \sin(4v) + 18 \cos(4v) = 0$ in $[2, 5]$

9. $2\left(\cos\left(\frac{2t}{7}\right) + 3\right) = 7 \cos\left(\frac{2t}{7}\right) + 6$ in $[-10, 30]$

10. $\frac{1}{2} \csc\left(\frac{y}{3}\right) - \frac{10}{7} = \frac{3}{14}$ in $[0, 32]$

11. $31 = 1 + 40 \cos\left(\frac{t}{8}\right)$ in $[-50, 60]$

12. $15 \csc(15x) + 14 = 20 - 12 \csc(15x)$ in $[1, 2]$

13. $\frac{1}{2} \cos(6t) + 3 = 1 + \frac{1}{3} \cos(6t)$ in $[0, 5]$

14. $4\left(1 - 2 \sec\left(\frac{z}{5}\right)\right) = 12$ in $[0, 15]$

15. $11 - 7 \sin\left(\frac{2x}{13}\right) = 23 - 19 \sin\left(\frac{2x}{13}\right)$ in $[-60, 60]$

1.6 Solving Trig Equations with Calculators, Part II

Find all the solution(s) to the following equations. These will require the use of a calculator so use at least 4 decimal places in your work.

1. $22 \cos(8 - x) + 10 = 0$

2. $10 \tan(4x + 10) - 7 = 31$

3. $4 \tan\left(\frac{w}{3}\right) \sin(2w) - \tan\left(\frac{w}{3}\right) = 0$

4. $3 \tan(4z) \sec(2z - 1) + \sec(2z - 1) = 0$

5. $2 - \sin(2y) = 3 \sin^2(2y)$

6. $4 \cos^2(2t + 5) - 4 \cos(2t + 5) = -1$

7. $6 - 5 \sin^2\left(\frac{x}{4}\right) = 7 \sin\left(\frac{x}{4}\right)$

8. $2 = 2 \tan^2(8t) + 3 \tan(8t)$

9. $35 \csc(4z) = z^3 \csc(4z)$

10. $3t = 8t \cos(5 + t)$

11. $(5x + 1) \sin\left(\frac{x - 6}{2}\right) + 25x + 5 = 0$

1.7 Exponential Functions

Sketch the graphs of each of the following functions.

1. $g(t) = 7^{3 - \frac{t}{2}}$

2. $f(x) = 3 - 5^{4x+1}$

3. $h(x) = 6e^{2x-1} - 3$

4. $f(t) = 7 + 9e^{2 - \frac{3t}{5}}$

1.8 Logarithm Functions

Without using a calculator determine the exact value of each of the following.

1. $\log_7 343$

2. $\log_4 1024$

3. $\log_{\frac{3}{8}} \frac{27}{512}$

4. $\log_{11} \frac{1}{121}$

5. $\log_{0.1} 0.0001$

6. $\log_{16} 4$

7. $\log 10000$

8. $\ln \frac{1}{\sqrt[5]{e}}$

Write each of the following in terms of simpler logarithms

9. $\log_7 (10a^7b^3c^{-8})$

10. $\log [z^2(x^2 + 4)^3]$

11. $\ln \left(\frac{w^2 \sqrt[4]{t^3}}{\sqrt{t+w}} \right)$

Combine each of the following into a single logarithm with a coefficient of one.

12. $7 \ln t - 6 \ln s + 5 \ln w$

13. $\frac{1}{2} \log (z + 1) - 2 \log x - 4 \log y - 3 \log z$

14. $2 \log_3 (x + y) + 6 \log_3 x - \frac{1}{3}$

Use the change of base formula and a calculator to find the value of each of the following.

15. $\log_7 100$

16. $\log_{\frac{5}{7}} \frac{1}{8}$

1.9 Exponential And Logarithm Equations

For problems 1 - 17 find all the solutions to the given equation. If there is no solution to the equation clearly explain why.

1. $15 = 12 + 5e^{10w-7}$

2. $4e^{2x+x^2} - 7 = 2$

3. $8 + 3e^{4-9z} = 1$

4. $4t^2 - 3t^2e^{2-t} = 0$

5. $7x + 16xe^{x^3-5x} = 0$

6. $3e^{7t} - 12e^{8t+5} = 0$

7. $2ye^{y^2} - 7ye^{1-5y} = 0$

8. $16 + 4\ln(x+2) = 7$

9. $3 - 11\ln\left(\frac{z}{3-z}\right) = 1$

10. $2\log(w) - \log(3w+7) = 1$

11. $\ln(3x+1) - \ln(x) = -2$

12. $t\log(6t+1) - 3t^2\log(6t+1) = 0$

13. $2\log(z) - \log(z^2+4z+1) = 0$

14. $\ln(x) + \ln(x-2) = 3$

15. $11 - 5^{9w-1} = 3$

16. $12 + 20^{7-2t} = 50$

17. $1 + 3^{z^2-2} = 5$

Compound Interest.

If we put P dollars into an account that earns interest at a rate of r (written as a decimal as opposed to the standard percent) for t years then,

1. if interest is compounded m times per year we will have,

$$A = P \left(1 + \frac{r}{m} \right)^{tm}$$

dollars after t years.

2. if interest is compounded continuously we will have,

$$A = Pe^{rt}$$

dollars after t years.

18. We have \$2,500 to invest and 80 months. How much money will we have if we put the money into an account that has an annual interest rate of 9% and interest is compounded
- (a) quarterly (b) monthly (c) continuously
19. We are starting with \$60,000 and we're going to put it into an account that earns an annual interest rate of 7.5%. How long will it take for the money in the account to reach \$100,000 if the interest is compounded
- (a) quarterly (b) monthly (c) continuously
20. Suppose that we put some money in an account that has an annual interest rate of 10.25%. How long will it take to triple our money if the interest is compounded
- (a) quarterly (b) monthly (c) continuously

Exponential Growth/Decay.

Many quantities in the world can be modeled (at least for a short time) by the exponential growth/decay equation.

$$Q = Q_0 e^{kt}$$

If k is positive we will get exponential growth and if k is negative we will get exponential decay.

21. A population of bacteria initially has 90,000 present and in 2 weeks there will be 200,000 bacteria present.
- (a) Determine the exponential growth equation for this population.
 - (b) How long will it take for the population to grow from its initial population of 90,000 to a population of 150,000?
22. We initially have 2 kg grams of some radioactive element and in 7250 years there will be 1.5 kg left.
- (a) Determine the exponential decay equation for this element.
 - (b) How long will it take for half of the element to decay?
 - (c) How long will it take until there is 250 grams of the element left?
23. For a particular radioactive element the value of k in the exponential decay equation is given by $k = 0.000825$.
- (a) How long will it take for a quarter of the element to decay?
 - (b) How long will it take for half of the element to decay?
 - (c) How long will it take 90

1.10 Common Graphs

Without using a graphing calculator sketch the graph of each of the following.

1. $y = -2x + 7$
2. $f(x) = |x + 4|$
3. $g(x) = \sqrt{x} - 5$
4. $g(x) = \tan\left(x + \frac{\pi}{3}\right)$
5. $f(x) = \sec(x) + 2$
6. $h(x) = |x + 2| - 4$
7. $Q(x) = e^{-x-3} + 6$
8. $V(x) = \sqrt{x-6} + 3$
9. $g(x) = \sin\left(x + \frac{\pi}{6}\right) - 1$
10. $h(x) = (x + 6)^2 - 8$
11. $W(y) = (y + 5)^2 + 3$
12. $f(y) = (y - 9)^2 - 2$
13. $f(x) = (x - 1)^2 + 6$
14. $R(x) = -\ln(x)$
15. $g(x) = \ln(-x)$
16. $h(x) = x^2 + 8x - 1$
17. $Y(x) = -3x^2 - 6x + 5$
18. $f(y) = -y^2 - 4y - 2$
19. $h(y) = 2y^2 + 2y - 3$
20. $x^2 - 6x + y^2 + 8y + 24 = 0$
21. $x^2 + y^2 + 10y = -9$
22. $\frac{(x + 4)^2}{25} + \frac{(y + 2)^2}{25} = 1$
23. $x^2 - 2x + 4y^2 - 16y + 16 = 0$

24.
$$\frac{(x+6)^2}{4} + 16(y-5)^2 = 1$$

25.
$$\frac{(y-1)^2}{25} - \frac{(x-3)^2}{4} = 1$$

26.
$$(x-4)^2 - 9(y+7)^2 = 1$$

2 Limits

The topic that we will be examining in this chapter is that of Limits. This is the first of three major topics that we will be covering in this course. While we will be spending the least amount of time on limits in comparison to the other two topics limits are very important in the study of Calculus. We will be seeing limits in a variety of places once we move out of this chapter. In particular we will see that limits are part of the formal definition of the other two major topics.

In this chapter we will discuss just what a limit tells us about a function as well as how they can be used to get the rate of change of a function as well as the slope of the line tangent to the graph of a function (although we'll be seeing other, easier, ways of doing these later). We will investigate limit properties as well as how a variety of techniques to employ when attempting to compute a limit. We will also look at limits whose "value" is infinity and how to compute limits at infinity.

In addition, we'll introduce the concept of continuity and how continuity is used in the Intermediate Value Theorem. The Intermediate Value Theorem is an important idea that has a variety of "real world" applications including showing that a function has a root (*i.e.* is equal to zero) in some interval.

Finally, we'll close out the chapter with the formal/precise definition of the Limit, sometimes called the delta-epsilon definition.

The following sections are the assignment problems (no solutions available) for this material.

If you are looking for some practice problems (with solutions available) please check out the [Practice Problems](#). There you will find a set of problems that should give you quite a bit practice.

2.1 Tangent Lines And Rates Of Change

1. For the function $f(x) = x^3 - 3x^2$ and the point P given by $x = 3$ answer each of the following questions.
- (a) For the points Q given by the following values of x compute (accurate to at least 8 decimal places) the slope, m_{PQ} , of the secant line through points P and Q .
- (i) 3.5 (ii) 3.1 (iii) 3.01 (iv) 3.001 (v) 3.0001
(vi) 2.5 (vii) 2.9 (viii) 2.99 (ix) 2.999 (x) 2.9999
- (b) Use the information from (a) to estimate the slope of the tangent line to $f(x)$ at $x = 3$ and write down the equation of the tangent line.
2. For the function $g(x) = \frac{x}{x^2 + 4}$ and the point P given by $x = 0$ answer each of the following questions.
- (a) For the points Q given by the following values of x compute (accurate to at least 8 decimal places) the slope, m_{PQ} , of the secant line through points P and Q .
- (i) 1 (ii) 0.5 (iii) 0.1 (iv) 0.01 (v) 0.001
(vi) -1 (vii) -0.5 (viii) -0.1 (ix) -0.01 (x) -0.001
- (b) Use the information from (a) to estimate the slope of the tangent line to $g(x)$ at $x = 0$ and write down the equation of the tangent line.
3. For the function $h(x) = 2 - (x + 2)^2$ and the point P given by $x = -2$ answer each of the following questions.
- (a) For the points Q given by the following values of x compute (accurate to at least 8 decimal places) the slope, m_{PQ} , of the secant line through points P and Q .
- (i) -2.5 (ii) -2.1 (iii) -2.01 (iv) -2.001 (v) -2.0001
(vi) -1.5 (vii) -1.9 (viii) -1.99 (ix) -1.999 (x) -1.9999
- (b) Use the information from (a) to estimate the slope of the tangent line to $h(x)$ at $x = -2$ and write down the equation of the tangent line.

4. For the function $P(x) = e^{2-8x^2}$ and the point P given by $x = 0.5$ answer each of the following questions.
- (a) For the points Q given by the following values of x compute (accurate to at least 8 decimal places) the slope, m_{PQ} , of the secant line through points P and Q .
- (i) 1 (ii) 0.51 (iii) 0.501 (iv) 0.5001 (v) 0.50001
- (vi) 0 (vii) 0.49 (viii) 0.499 (ix) 0.4999 (x) 0.49999
- (b) Use the information from (a) to estimate the slope of the tangent line to $h(x)$ at $x = 0.5$ and write down the equation of the tangent line.
5. The amount of grain in a bin is given by $V(t) = \frac{11t + 4}{t + 4}$ answer each of the following questions.
- (a) Compute (accurate to at least 8 decimal places) the average rate of change of the amount of grain in the bin between $t = 6$ and the following values of t .
- (i) 6.5 (ii) 6.1 (iii) 6.01 (iv) 6.001 (v) 6.0001
- (vi) 5.5 (vii) 5.9 (viii) 5.99 (ix) 5.999 (x) 5.9999
- (b) Use the information from (a) to estimate the instantaneous rate of change of the volume of grain in the bin at $t = 6$.
6. The population (in thousands) of insects is given by $P(t) = 2 - \frac{1}{\pi} \cos(3\pi t) \sin\left(\frac{\pi t}{2}\right)$ answer each of the following questions.
- (a) Compute (accurate to at least 8 decimal places) the average rate of change of the population of insects between $t = 4$ and the following values of t . Make sure your calculator is set to radians for the computations.
- (i) 4.5 (ii) 4.1 (iii) 4.01 (iv) 4.001 (v) 4.0001
- (vi) 3.5 (vii) 3.9 (viii) 3.99 (ix) 3.999 (x) 3.9999
- (b) Use the information from (a) to estimate the instantaneous rate of change of the population of the insects at $t = 4$.

7. The amount of water in a holding tank is given by $V(t) = 8t^4 - t^2 + 7$ answer each of the following questions.
- (a) Compute (accurate to at least 8 decimal places) the average rate of change of the amount of grain in the bin between $t = 0.25$ and the following values of t .
- (i) 1 (ii) 0.5 (iii) 0.251 (iv) 0.2501 (v) 0.25001
- (vi) 0 (vii) 0.1 (viii) 0.249 (ix) 0.2499 (x) 0.24999
- (b) Use the information from (a) to estimate the instantaneous rate of change of the volume of water in the tank at $t = 0.25$.
8. The position of an object is given by $s(t) = x^2 + \frac{72}{x+1}$ answer each of the following questions.
- (a) Compute (accurate to at least 8 decimal places) the average velocity of the object between $t = 5$ and the following values of t .
- (i) 5.5 (ii) 5.1 (iii) 5.01 (iv) 5.001 (v) 5.0001
- (vi) 4.5 (vii) 4.9 (viii) 4.99 (ix) 4.999 (x) 4.9999
- (b) Use the information from (a) to estimate the instantaneous velocity of the object at $t = 5$ and determine if the object is moving to the right (*i.e.* the instantaneous velocity is positive), moving to the left (*i.e.* the instantaneous velocity is negative), or not moving (*i.e.* the instantaneous velocity is zero).
9. The position of an object is given by $s(t) = 2 \cos(4t - 8) - 7 \sin(t - 2)$. Note that a negative position here simply means that the position is to the left of the “zero position” and is perfectly acceptable. Answer each of the following questions.
- (a) Compute (accurate to at least 8 decimal places) the average velocity of the object between $t = 2$ and the following values of t . Make sure your calculator is set to radians for the computations.
- (i) 2.5 (ii) 2.1 (iii) 2.01 (iv) 2.001 (v) 2.0001
- (vi) 1.5 (vii) 1.9 (viii) 1.99 (ix) 1.999 (x) 1.9999
- (b) Use the information from (a) to estimate the instantaneous velocity of the object at $t = 2$ and determine if the object is moving to the right (*i.e.* the instantaneous velocity is positive), moving to the left (*i.e.* the instantaneous velocity is negative), or not moving (*i.e.* the instantaneous velocity is zero).

10. The position of an object is given by $s(t) = t^2 - 10t + 11$. Note that a negative position here simply means that the position is to the left of the “zero position” and is perfectly acceptable. Answer each of the following questions.
- (a) Determine the time(s) in which the position of the object is at $s = -5$.
- (b) Estimate the instantaneous velocity of the object at each of the time(s) found in part (a) using the method discussed in this section.

2.2 The Limit

1. For the function $g(x) = \frac{x^2 + 6x + 9}{x^2 + 3x}$ answer each of the following questions.

(a) Evaluate the function the following values of x compute (accurate to at least 8 decimal places).

(i) -2.5 (ii) -2.9 (iii) -2.99 (iv) -2.999 (v) -2.9999

(vi) -3.5 (vii) -3.1 (viii) -3.01 (ix) -3.001 (x) -3.0001

(b) Use the information from (a) to estimate the value of $\lim_{x \rightarrow -3} \frac{x^2 + 6x + 9}{x^2 + 3x}$.

2. For the function $f(z) = \frac{10z - 9 - z^2}{z^2 - 1}$ answer each of the following questions.

(a) Evaluate the function the following values of t compute (accurate to at least 8 decimal places).

(i) 1.5 (ii) 1.1 (iii) 1.01 (iv) 1.001 (v) 1.0001

(vi) 0.5 (vii) 0.9 (viii) 0.99 (ix) 0.999 (x) 0.9999

(b) Use the information from (a) to estimate the value of $\lim_{z \rightarrow 1} \frac{10z - 9 - z^2}{z^2 - 1}$.

3. For the function $h(t) = \frac{2 - \sqrt{4 + 2t}}{t}$ answer each of the following questions.

(a) Evaluate the function the following values of t compute (accurate to at least 8 decimal places). Make sure your calculator is set to radians for the computations.

(i) 0.5 (ii) 0.1 (iii) 0.01 (iv) 0.001 (v) 0.0001

(vi) -0.5 (vii) -0.1 (viii) -0.01 (ix) -0.001 (x) -0.0001

(b) Use the information from (a) to estimate the value of $\lim_{t \rightarrow 0} \frac{2 - \sqrt{4 + 2t}}{t}$.

4. For the function $g(\theta) = \frac{\cos(\theta - 4) - 1}{2\theta - 8}$ answer each of the following questions.

(a) Evaluate the function the following values of θ compute (accurate to at least 8 decimal places). Make sure your calculator is set to radians for the computations.

(i) 4.5 (ii) 4.1 (iii) 4.01 (iv) 4.001 (v) 4.0001

(vi) 3.5 (vii) 3.9 (viii) 3.99 (ix) 3.999 (x) 3.9999

(b) Use the information from (a) to estimate the value of $\lim_{\theta \rightarrow 4} \frac{\cos(\theta - 4) - 1}{2\theta - 8}$.

5. Below is the graph of $f(x)$. For each of the given points determine the value of $f(a)$ and $\lim_{x \rightarrow a} f(x)$. If any of the quantities do not exist clearly explain why.

(a) $a = -2$

(b) $a = -1$

(c) $a = 2$

(d) $a = 3$

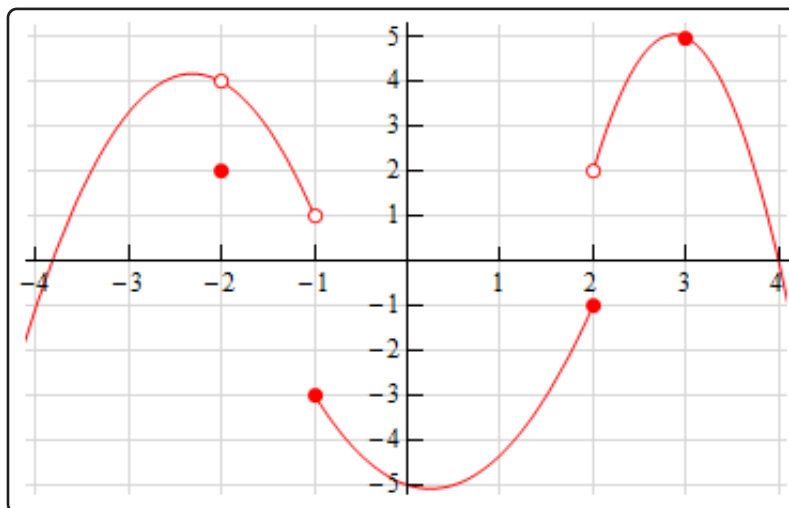

6. Below is the graph of $f(x)$. For each of the given points determine the value of $f(a)$ and $\lim_{x \rightarrow a} f(x)$. If any of the quantities do not exist clearly explain why.

(a) $a = -3$

(b) $a = -1$

(c) $a = 1$

(d) $a = 3$

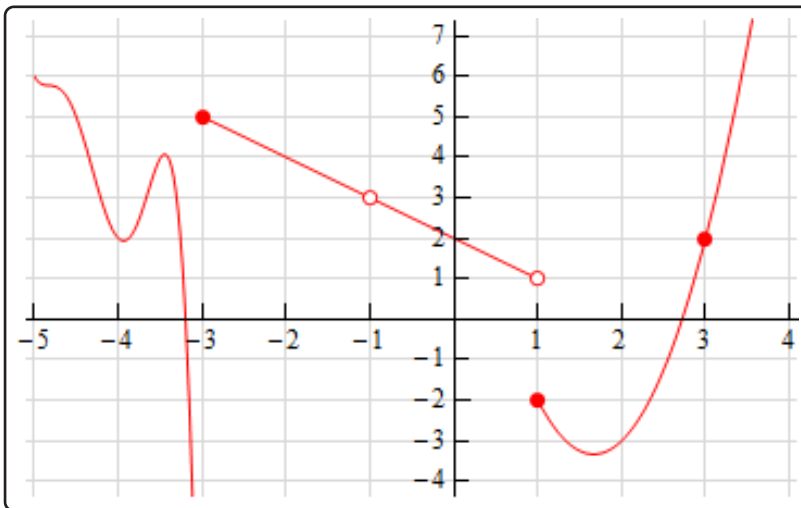

7. Below is the graph of $f(x)$. For each of the given points determine the value of $f(a)$ and $\lim_{x \rightarrow a} f(x)$. If any of the quantities do not exist clearly explain why.

(a) $a = -4$

(b) $a = -2$

(c) $a = 1$

(d) $a = 4$

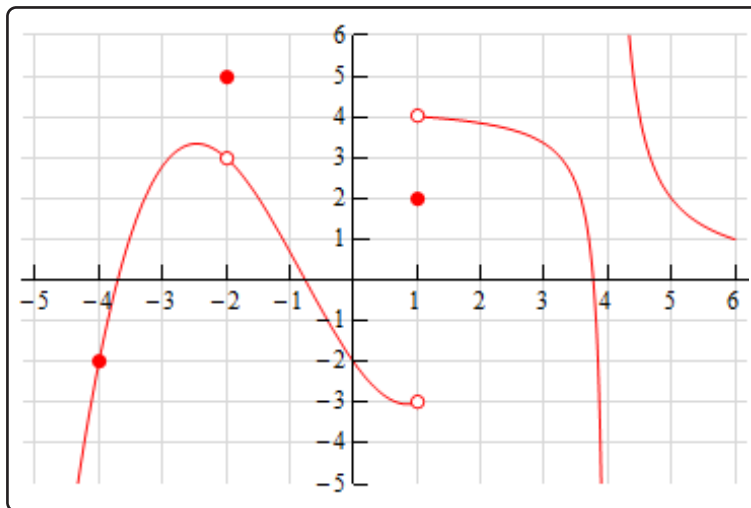

8. Explain in your own words what the following equation means.

$$\lim_{x \rightarrow 12} f(x) = 6$$

9. Suppose we know that $\lim_{x \rightarrow -7} f(x) = 18$. If possible, determine the value of $f(-7)$. If it is not possible to determine the value explain why not.
10. Is it possible to have $\lim_{x \rightarrow 1} f(x) = -23$ and $f(1) = 107$? Explain your answer.

2.3 One-Sided Limits

1. Below is the graph of $f(x)$. For each of the given points determine the value of $f(a)$, $\lim_{x \rightarrow a^-} f(x)$, $\lim_{x \rightarrow a^+} f(x)$, and $\lim_{x \rightarrow a} f(x)$. If any of the quantities do not exist clearly explain why.

(a) $a = -5$

(b) $a = -2$

(c) $a = 1$

(d) $a = 4$

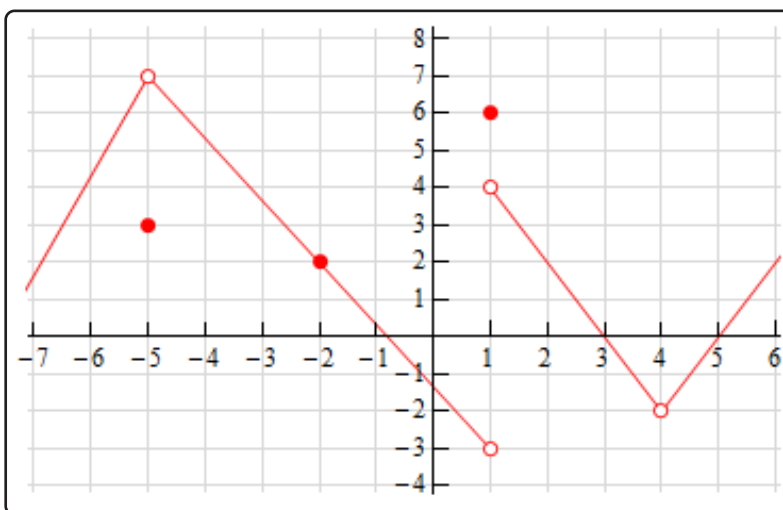

2. Below is the graph of $f(x)$. For each of the given points determine the value of $f(a)$, $\lim_{x \rightarrow a^-} f(x)$, $\lim_{x \rightarrow a^+} f(x)$, and $\lim_{x \rightarrow a} f(x)$. If any of the quantities do not exist clearly explain why.

(a) $a = -1$

(b) $a = 1$

(c) $a = 3$

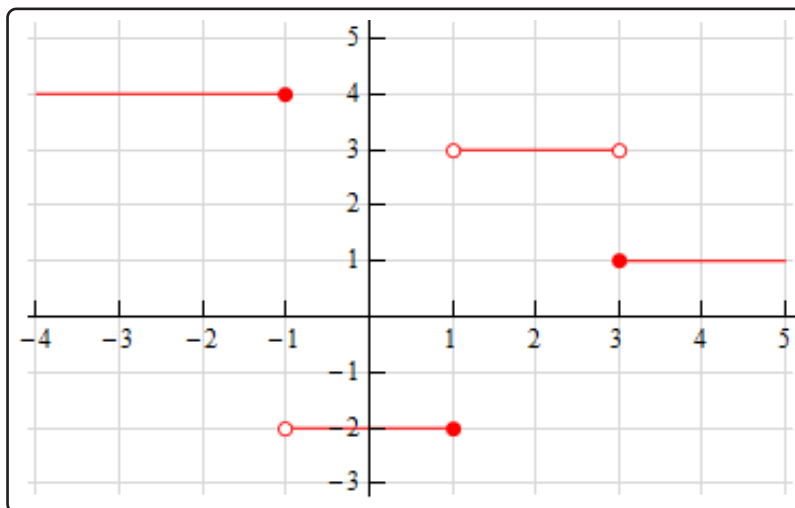

3. Below is the graph of $f(x)$. For each of the given points determine the value of $f(a)$, $\lim_{x \rightarrow a^-} f(x)$, $\lim_{x \rightarrow a^+} f(x)$, and $\lim_{x \rightarrow a} f(x)$. If any of the quantities do not exist clearly explain why.

(a) $a = -3$

(b) $a = -1$

(c) $a = 1$

(d) $a = 2$

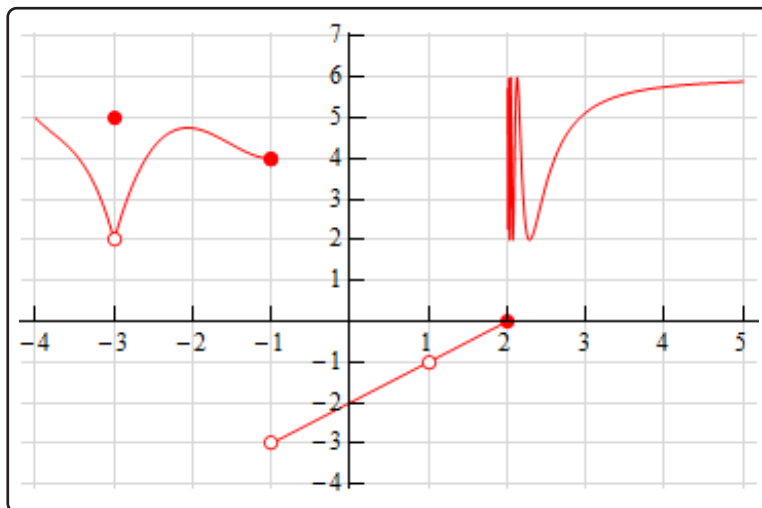

4. Sketch a graph of a function that satisfies each of the following conditions.

$$\lim_{x \rightarrow 1^-} f(x) = -2$$

$$\lim_{x \rightarrow 1^+} f(x) = 3$$

$$f(1) = 6$$

5. Sketch a graph of a function that satisfies each of the following conditions.

$$\lim_{x \rightarrow -3^-} f(x) = 1$$

$$\lim_{x \rightarrow -3^+} f(x) = 1$$

$$f(-3) = 4$$

6. Sketch a graph of a function that satisfies each of the following conditions.

$$\lim_{x \rightarrow -5^-} f(x) = -1$$

$$\lim_{x \rightarrow -5^+} f(x) = 7$$

$$f(-5) = 4$$

$$\lim_{x \rightarrow 4} f(x) = 6 \quad f(4) \text{ does not exist}$$

7. Explain in your own words what each of the following equations mean.

$$\lim_{x \rightarrow 8^-} f(x) = 3$$

$$\lim_{x \rightarrow 8^+} f(x) = -1$$

8. Suppose we know that $\lim_{x \rightarrow -7} f(x) = 18$. If possible, determine the value of $\lim_{x \rightarrow -7^-} f(x)$ and the value of $\lim_{x \rightarrow -7^+} f(x)$. If it is not possible to determine one or both of these values explain why not.

9. Suppose we know that $f(6) = -53$. If possible, determine the value of $\lim_{x \rightarrow 6^-} f(x)$ and the value of $\lim_{x \rightarrow 6^+} f(x)$. If it is not possible to determine one or both of these values explain why not.

2.4 Limit Properties

1. Given $\lim_{x \rightarrow 0} f(x) = 5$, $\lim_{x \rightarrow 0} g(x) = -1$ and $\lim_{x \rightarrow 0} h(x) = -3$ use the limit properties given in this section to compute each of the following limits. If it is not possible to compute any of the limits clearly explain why not.

(a) $\lim_{x \rightarrow 0} [11 + 7f(x)]$

(b) $\lim_{x \rightarrow 0} [6 - 4g(x) - 10h(x)]$

(c) $\lim_{x \rightarrow 0} [4g(x) - 12f(x) + 3h(x)]$

(d) $\lim_{x \rightarrow 0} [g(x)(1 + 2f(x))]$

2. Given $\lim_{x \rightarrow 12} f(x) = 2$, $\lim_{x \rightarrow 12} g(x) = 6$ and $\lim_{x \rightarrow 12} h(x) = 9$ use the limit properties given in this section to compute each of the following limits. If it is not possible to compute any of the limits clearly explain why not.

(a) $\lim_{x \rightarrow 12} \left[h(x)f(x) + \frac{1 + g(x)}{g(x)} \right]$

(b) $\lim_{x \rightarrow 12} [(3 - f(x))(1 + 2g(x))]$

(c) $\lim_{x \rightarrow 12} \frac{f(x) + 1}{3g(x) - 2h(x)}$

(d) $\lim_{x \rightarrow 12} \frac{f(x) - 2g(x)}{7 + h(x)f(x)}$

3. Given $\lim_{x \rightarrow -1} f(x) = 0$, $\lim_{x \rightarrow -1} g(x) = 9$ and $\lim_{x \rightarrow -1} h(x) = -7$ use the limit properties given in this section to compute each of the following limits. If it is not possible to compute any of the limits clearly explain why not.

(a) $\lim_{x \rightarrow -1} [(g(x))^2 - (h(x))^3]$

(b) $\lim_{x \rightarrow -1} \sqrt{3 + 6f(x) - h(x)}$

(c) $\lim_{x \rightarrow -1} \sqrt{f(x) - g(x)h(x)}$

(d) $\lim_{x \rightarrow -1} \sqrt[4]{\frac{2 + g(x)}{1 - 10h(x)}}$

For each of the following limits use the limit properties given in this section to compute the limit. At each step clearly indicate the property being used. If it is not possible to compute any of the limits clearly explain why not.

4. $\lim_{x \rightarrow 4} (3x^2 - 9x + 2)$

5. $\lim_{w \rightarrow -1} (w - (w^2 + 3)^2)$

6. $\lim_{t \rightarrow 0} (t^4 - 4t^2 + 12t - 8)$

7. $\lim_{z \rightarrow 2} \frac{10 + z^2}{3 - 4z}$

8. $\lim_{x \rightarrow 7} \frac{8x}{x^2 - 14x + 49}$

9. $\lim_{y \rightarrow -3} \frac{y^3 - 20y + 4}{y^2 + 8y - 1}$

10. $\lim_{w \rightarrow -6} \sqrt[3]{8 + 7w}$

11. $\lim_{t \rightarrow 1} (4t^2 - \sqrt{8t + 1})$

12. $\lim_{x \rightarrow 8} (\sqrt[4]{3x - 8} + \sqrt{9 + 2x})$

2.5 Computing Limits

For problems 1 - 20 evaluate the limit, if it exists.

1. $\lim_{x \rightarrow -9} (1 - 4x^3)$

2. $\lim_{y \rightarrow 1} (6y^4 - 7y^3 + 12y + 25)$

3. $\lim_{t \rightarrow 0} \frac{t^2 + 6}{t^2 - 3}$

4. $\lim_{z \rightarrow 4} \frac{6z}{2 + 3z^2}$

5. $\lim_{w \rightarrow -2} \frac{w + 2}{w^2 - 6w - 16}$

6. $\lim_{t \rightarrow -5} \frac{t^2 + 6t + 5}{t^2 + 2t - 15}$

7. $\lim_{x \rightarrow 3} \frac{5x^2 - 16x + 3}{9 - x^2}$

8. $\lim_{z \rightarrow 1} \frac{10 - 9z - z^2}{3z^2 + 4z - 7}$

9. $\lim_{x \rightarrow -2} \frac{x^3 + 8}{x^2 + 8x + 12}$

10. $\lim_{t \rightarrow 8} \frac{t(t - 5) - 24}{t^2 - 8t}$

11. $\lim_{w \rightarrow -4} \frac{w^2 - 16}{(w - 2)(w + 3) - 6}$

12. $\lim_{h \rightarrow 0} \frac{(2 + h)^3 - 8}{h}$

13. $\lim_{h \rightarrow 0} \frac{(1 + h)^4 - 1}{h}$

14. $\lim_{t \rightarrow 25} \frac{5 - \sqrt{t}}{t - 25}$

15. $\lim_{x \rightarrow 2} \frac{x - 2}{\sqrt{2} - \sqrt{x}}$

16. $\lim_{z \rightarrow 6} \frac{z - 6}{\sqrt{3z - 2} - 4}$

$$17. \lim_{z \rightarrow -2} \frac{3 - \sqrt{1 - 4z}}{2z + 4}$$

$$18. \lim_{t \rightarrow 3} \frac{3 - t}{\sqrt{t + 1} - \sqrt{5t - 11}}$$

$$19. \lim_{x \rightarrow 7} \frac{\frac{1}{7} - \frac{1}{x}}{x - 7}$$

$$20. \lim_{y \rightarrow -1} \frac{\frac{1}{4+3y} + \frac{1}{y}}{y + 1}$$

21. Given the function

$$f(x) = \begin{cases} 15 & x < -4 \\ 6 - 2x & x \geq -4 \end{cases}$$

Evaluate the following limits, if they exist.

$$(a) \lim_{x \rightarrow -7} f(x)$$

$$(b) \lim_{x \rightarrow -4} f(x)$$

22. Given the function

$$g(t) = \begin{cases} t^2 - t^3 & t < 2 \\ 5t - 14 & t \geq 2 \end{cases}$$

Evaluate the following limits, if they exist.

$$(a) \lim_{t \rightarrow -3} g(t)$$

$$(b) \lim_{t \rightarrow 2} g(t)$$

23. Given the function

$$h(w) = \begin{cases} 2w^2 & w \leq 6 \\ w - 8 & w > 6 \end{cases}$$

Evaluate the following limits, if they exist.

$$(a) \lim_{w \rightarrow 6} h(w)$$

$$(b) \lim_{w \rightarrow 2} h(w)$$

24. Given the function

$$g(x) = \begin{cases} 5x + 24 & x < -3 \\ x^2 & -3 \leq x < 4 \\ 1 - 2x & x \geq 4 \end{cases}$$

Evaluate the following limits, if they exist.

$$(a) \lim_{x \rightarrow -3} g(x)$$

$$(b) \lim_{x \rightarrow 0} g(x)$$

$$(c) \lim_{x \rightarrow 4} g(x)$$

$$(d) \lim_{x \rightarrow 12} g(x)$$

For problems 25 - 30 evaluate the limit, if it exists.

25. $\lim_{z \rightarrow -10} (|t + 10| + 3)$

26. $\lim_{x \rightarrow 4} (9 + |8 - 2x|)$

27. $\lim_{h \rightarrow 0} \frac{|h|}{h}$

28. $\lim_{t \rightarrow 2} \frac{2 - t}{|t - 2|}$

29. $\lim_{w \rightarrow -5} \frac{|2w + 10|}{w + 5}$

30. $\lim_{x \rightarrow 4} \frac{|x - 4|}{x^2 - 16}$

31. Given that $3 + 2x \leq f(x) \leq x - 1$ for all x determine the value of $\lim_{x \rightarrow -4} f(x)$.

32. Given that $\sqrt{x+7} \leq f(x) \leq \frac{x-1}{2}$ for all x determine the value of $\lim_{x \rightarrow 9} f(x)$.

33. Use the Squeeze Theorem to determine the value of $\lim_{x \rightarrow 0} x^4 \cos\left(\frac{3}{x}\right)$.

34. Use the Squeeze Theorem to determine the value of $\lim_{x \rightarrow 0} x \cos\left(\frac{1}{x}\right)$.

35. Use the Squeeze Theorem to determine the value of $\lim_{x \rightarrow 1} (x - 1)^2 \cos\left(\frac{1}{x - 1}\right)$.

2.6 Infinite Limits

For problems 1 - 8 evaluate the indicated limits, if they exist.

1. For $g(x) = \frac{-4}{(x-1)^2}$ evaluate,

(a) $\lim_{x \rightarrow 1^-} g(x)$

(b) $\lim_{x \rightarrow 1^+} g(x)$

(c) $\lim_{x \rightarrow 1} g(x)$

2. For $h(z) = \frac{17}{(4-z)^3}$ evaluate,

(a) $\lim_{z \rightarrow 4^-} h(z)$

(b) $\lim_{z \rightarrow 4^+} h(z)$

(c) $\lim_{z \rightarrow 4} h(z)$

3. For $g(t) = \frac{4t^2}{(t+3)^7}$ evaluate,

(a) $\lim_{t \rightarrow -3^-} g(t)$

(b) $\lim_{t \rightarrow -3^+} g(t)$

(c) $\lim_{t \rightarrow -3} g(t)$

4. For $f(x) = \frac{1+x}{x^3+8}$ evaluate,

(a) $\lim_{x \rightarrow -2^-} f(x)$

(b) $\lim_{x \rightarrow -2^+} f(x)$

(c) $\lim_{x \rightarrow -2} f(x)$

5. For $f(x) = \frac{x-1}{(x^2-9)^4}$ evaluate,

(a) $\lim_{x \rightarrow 3^-} f(x)$

(b) $\lim_{x \rightarrow 3^+} f(x)$

(c) $\lim_{x \rightarrow 3} f(x)$

6. For $W(t) = \ln(t+8)$ evaluate,

(a) $\lim_{t \rightarrow -8^-} W(t)$

(b) $\lim_{t \rightarrow -8^+} W(t)$

(c) $\lim_{t \rightarrow -8} W(t)$

7. For $h(z) = \ln|z|$ evaluate,

(a) $\lim_{z \rightarrow 0^-} h(z)$

(b) $\lim_{z \rightarrow 0^+} h(z)$

(c) $\lim_{z \rightarrow 0} h(z)$

8. For $R(y) = \cot(y)$ evaluate,

(a) $\lim_{y \rightarrow \pi^-} R(y)$

(b) $\lim_{y \rightarrow \pi^+} R(y)$

(c) $\lim_{y \rightarrow \pi} R(y)$

For problems 9 - 12 find all the vertical asymptotes of the given function.

$$9. h(x) = \frac{-6}{9-x}$$

$$10. f(x) = \frac{x+8}{x^2(5-2x)^3}$$

$$11. g(t) = \frac{5t}{t(t+7)(t-12)}$$

$$12. g(z) = \frac{z^2+1}{(z^2-1)^5(z+15)^6}$$

2.7 Limits at Infinity, Part I

1. For $f(x) = 8x + 9x^3 - 11x^5$ evaluate each of the following limits.

(a) $\lim_{x \rightarrow -\infty} f(x)$

(b) $\lim_{x \rightarrow \infty} f(x)$

2. For $h(t) = 10t^2 + t^4 + 6t - 2$ evaluate each of the following limits.

(a) $\lim_{x \rightarrow -\infty} f(x)$

(b) $\lim_{x \rightarrow \infty} f(x)$

3. For $g(z) = 7 + 8z + \sqrt[3]{z^4}$ evaluate each of the following limits.

(a) $\lim_{x \rightarrow -\infty} f(x)$

(b) $\lim_{x \rightarrow \infty} f(x)$

For problems 4 - 17 answer each of the following questions.

(a) Evaluate $\lim_{x \rightarrow -\infty} f(x)$

(b) Evaluate $\lim_{x \rightarrow \infty} f(x)$

(c) Write down the equation(s) of any horizontal asymptotes for the function.

4. $f(x) = \frac{10x^3 - 6x}{7x^3 + 9}$

5. $f(x) = \frac{12 + x}{3x^2 - 8x + 23}$

6. $f(x) = \frac{5x^8 - 9}{x^3 + 10x^5 - 3x^8}$

7. $f(x) = \frac{2 - 6x - 9x^2}{15x^2 + x - 4}$

8. $f(x) = \frac{5x + 7x^4}{4 - x^2}$

9. $f(x) = \frac{4x^3 - 3x^2 + 2x - 1}{10 - 5x + x^3}$

10. $f(x) = \frac{5 - x^8}{2x^3 - 7x + 1}$

11. $f(x) = \frac{1 + 4\sqrt[3]{x^2}}{9 + 10x}$

$$12. f(x) = \frac{25x + 7}{\sqrt{5x^2 + 2}}$$

$$13. f(x) = \frac{\sqrt{8 + 11x^2}}{-9 - x}$$

$$14. f(x) = \frac{\sqrt{9x^4 + 2x^2 + 3}}{5x - 2x^2}$$

$$15. f(x) = \frac{6 + x^3}{\sqrt{8 + 4x^6}}$$

$$16. f(x) = \frac{\sqrt[3]{2 - 8x^3}}{4 + 7x}$$

$$17. f(x) = \frac{1 + x}{\sqrt[4]{5 + 2x^4}}$$

2.8 Limits at Infinity, Part II

For problems 1 - 11 evaluate (a) $\lim_{x \rightarrow -\infty} f(x)$ and (b) $\lim_{x \rightarrow \infty} f(x)$.

1. $f(x) = e^{x^4+8x}$

2. $f(x) = e^{2x+4x^2+2x^5}$

3. $f(x) = e^{\frac{3-x^3}{x+x^2}}$

4. $f(x) = e^{\frac{5-9x}{7+3x}}$

5. $f(x) = e^{\frac{5+2x^6}{x-8x^4}}$

6. $f(x) = e^x + 12e^{-3x} - 2e^{-10x}$

7. $f(x) = 9e^{2x} - 7e^{-14x} - e^x$

8. $f(x) = 20e^{-8x} - e^{5x} + 3e^{2x} - e^{-7x}$

9. $f(x) = \frac{6e^{4x} + e^{-15x}}{11e^{4x} + 6e^{-15x}}$

10. $f(x) = \frac{e^{3x} + 9e^{-x} - 4e^{10x}}{2e^{7x} - e^{-x}}$

11. $f(x) = \frac{3e^{-14x} - e^{18x}}{e^{-x} - 2e^{20x} - e^{-9x}}$

For problems 12 - 20 evaluate the given limit.

12. $\lim_{x \rightarrow \infty} \ln(5x^2 + 12x - 6)$

13. $\lim_{y \rightarrow -\infty} \ln(5 - 7y^5)$

14. $\lim_{x \rightarrow \infty} \ln\left(\frac{3+x}{1+5x^3}\right)$

15. $\lim_{t \rightarrow -\infty} \ln\left(\frac{2t - 5t^3}{4 + 3t^2}\right)$

16. $\lim_{z \rightarrow \infty} \ln\left(\frac{10z + 8z^2}{z^2 - 1}\right)$

17. $\lim_{x \rightarrow -\infty} \tan^{-1}(7 + 4x - x^3)$

$$18. \lim_{w \rightarrow \infty} \tan^{-1}(4w^2 - w^6)$$

$$19. \lim_{t \rightarrow \infty} \tan^{-1}\left(\frac{4t^3 + t^2}{1 + 3t}\right)$$

$$20. \lim_{z \rightarrow -\infty} \tan^{-1}\left(\frac{z^4 + 4}{3z^2 + 5z^3}\right)$$

2.9 Continuity

1. The graph of $f(x)$ is given below. Based on this graph determine where the function is discontinuous.

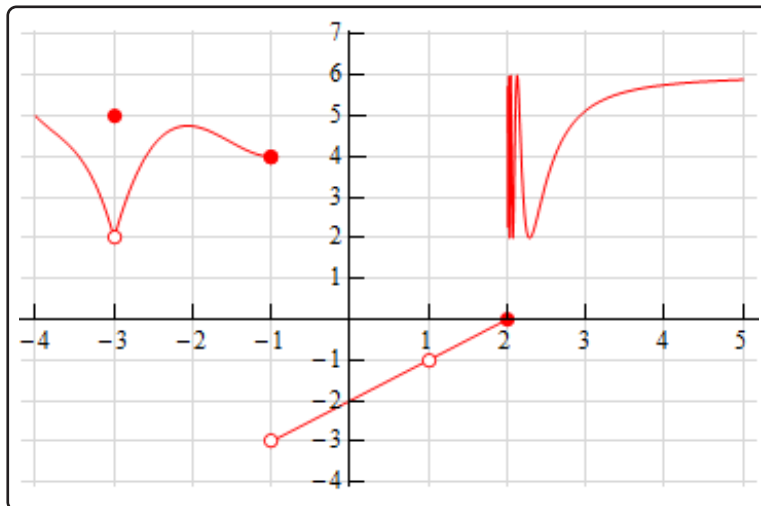

2. The graph of $f(x)$ is given below. Based on this graph determine where the function is discontinuous.

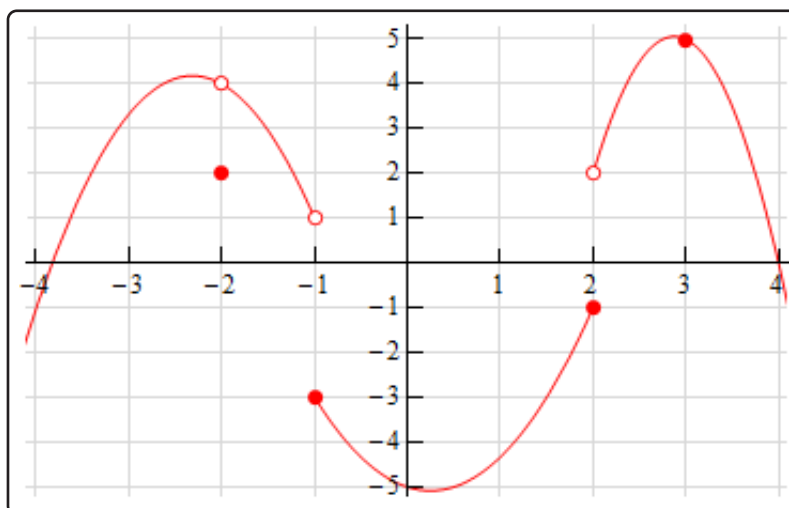

3. The graph of $f(x)$ is given below. Based on this graph determine where the function is discontinuous.

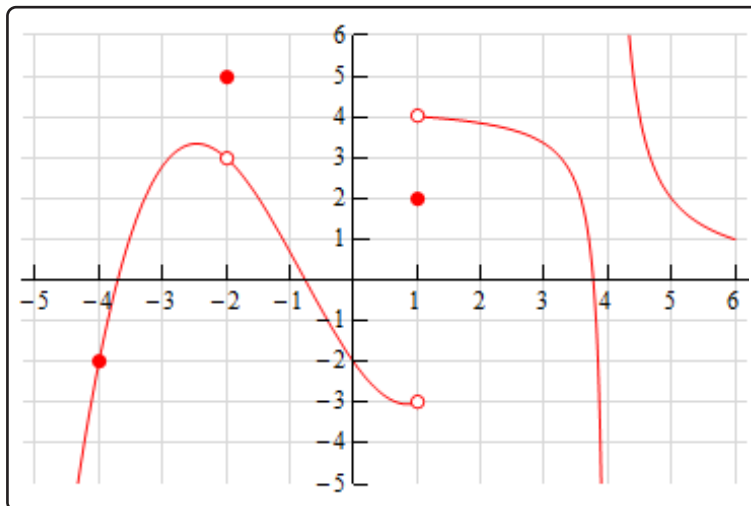

For problems 4 - 13 using only Properties 1- 9 from the [Limit Properties](#) section, one-sided limit properties (if needed) and the definition of continuity determine if the given function is continuous or discontinuous at the indicated points.

4. $f(x) = \frac{6 + 2x}{7x - 14}$

(a) $x = -3$

(b) $x = 0$

(c) $x = 2$

5. $R(y) = \frac{2y}{y^2 - 25}$

(a) $y = -5$

(b) $y = -1$

(c) $y = 3$

6. $g(z) = \frac{5z - 20}{z^2 - 12z}$

(a) $z = -1$

(b) $z = 0$

(c) $z = 4$

7. $W(x) = \frac{2 + x}{x^2 + 6x - 7}$

(a) $x = -7$

(b) $x = 0$

(c) $x = 1$

8. $h(z) = \begin{cases} 2z^2 & z < -1 \\ 4z + 6 & z \geq -1 \end{cases}$

(a) $z = -6$

(b) $z = -1$

$$9. g(x) = \begin{cases} x + e^x & x < 0 \\ x^2 & x \geq 0 \end{cases}$$

(a) $x = 0$

(b) $x = 4$

$$10. Z(t) = \begin{cases} 8 & t < 5 \\ 1 - 6t & t \geq 5 \end{cases}$$

(a) $t = 0$

(b) $t = 5$

$$11. h(z) = \begin{cases} z + 2 & z < -4 \\ 0 & z = -4 \\ 18 - z^2 & z > -4 \end{cases}$$

(a) $z = -4$

(b) $z = 2$

$$12. f(x) = \begin{cases} 1 - x^2 & x < 2 \\ -3 & x = 2 \\ 2x - 7 & 2 < x < 7 \\ 0 & x = 7 \\ x^2 & x > 7 \end{cases}$$

(a) $x = 2$

(b) $x = 7$

$$13. g(w) = \begin{cases} 3w & w < 0 \\ 0 & w = 0 \\ w + 6 & 0 < w < 8 \\ 14 & w = 8 \\ 22 - w & w > 8 \end{cases}$$

(a) $w = 0$

(b) $w = 8$

For problems 14 - 22 determine where the given function is discontinuous.

$$14. f(x) = \frac{11 - 2x}{2x^2 - 13x - 7}$$

$$15. Q(z) = \frac{3}{2z^2 + 3z - 4}$$

$$16. h(t) = \frac{t^2 - 1}{t^3 + 6t^2 + t}$$

$$17. f(z) = \frac{4z + 1}{5 \cos\left(\frac{z}{2}\right) + 1}$$

18. $h(x) = \frac{1-x}{x \sin(x-1)}$

19. $f(x) = \frac{3}{4e^{x-7} - 1}$

20. $R(w) = \frac{e^{w^2+1}}{e^w - 2e^{1-w}}$

21. $g(x) = \cot(4x)$

22. $f(t) = \sec(\sqrt{t})$

For problems 23 - 27 use the Intermediate Value Theorem to show that the given equation has at least one solution in the indicated interval. Note that you are NOT asked to find the solution only show that at least one must exist in the indicated interval.

23. $1 + 7x^3 - x^4 = 0$ on $[4, 8]$

24. $z^2 + 11z = 3$ on $[-15, -5]$

25. $\frac{t^2 + t - 15}{t - 8} = 0$ on $[-5, 1]$

26. $\ln(2t^2 + 1) - \ln(t^2 + 4) = 0$ on $[-1, 2]$

27. $10 = w^3 + w^2e^{-w} - 5$ on $[0, 4]$

For problems 28 - 33 assume that $f(x)$ is continuous everywhere unless otherwise indicated in some way. From the given information is it possible to determine if there is a root of $f(x)$ in the given interval?

If it is possible to determine that there is a root in the given interval clearly explain how you know that a root must exist. If it is not possible to determine if there is a root in the interval sketch a graph of two functions each of which meets the given information and one will have a root in the given interval and the other will not have a root in the given interval.

28. $f(-5) = 12$ and $f(0) = -3$ on the interval $[-5, 0]$.

29. $f(1) = 30$ and $f(9) = 6$ on the interval $[1, 9]$.

30. $f(20) = -100$ and $f(40) = -100$ on the interval $[20, 40]$.

31. $f(-4) = -10$, $f(5) = 17$, $\lim_{x \rightarrow 1^-} f(x) = -2$, and $\lim_{x \rightarrow 1^+} f(x) = 4$ on the interval $[-4, 5]$.

32. $f(-8) = 2$, $f(1) = 23$, $\lim_{x \rightarrow -4^-} f(x) = 35$, and $\lim_{x \rightarrow -4^+} f(x) = 1$ on the interval $[-8, 1]$.

33. $f(0) = -1$, $f(9) = 10$, $\lim_{x \rightarrow 2^-} f(x) = -12$, and $\lim_{x \rightarrow 2^+} f(x) = -3$ on the interval $[0, 9]$.

2.10 The Definition of the Limit

Use the definition of the limit to prove the following limits.

1. $\lim_{x \rightarrow -4} (2x) = -8$

2. $\lim_{x \rightarrow 1} (-7x) = -7$

3. $\lim_{x \rightarrow 3} (2x + 8) = 14$

4. $\lim_{x \rightarrow 2} (5 - x) = 3$

5. $\lim_{x \rightarrow -2} x^2 = 4$

6. $\lim_{x \rightarrow 4} x^2 = 16$

7. $\lim_{x \rightarrow 1} (x^2 + x + 6) = 8$

8. $\lim_{x \rightarrow -2} (x^2 + 3x - 1) = -3$

9. $\lim_{x \rightarrow 1} x^4 = 1$

10. $\lim_{x \rightarrow -6} \frac{1}{(x + 6)^2} = \infty$

11. $\lim_{x \rightarrow 0} \frac{-3}{x^2} = -\infty$

12. $\lim_{x \rightarrow 0^+} \frac{1}{x} = \infty$

13. $\lim_{x \rightarrow 1^-} \frac{1}{x - 1} = -\infty$

14. $\lim_{x \rightarrow -\infty} \frac{1}{x^2} = 0$

15. $\lim_{x \rightarrow \infty} \frac{1}{x^3} = 0$

3 Derivatives

In this chapter we will start looking at the next major topic in a calculus class, derivatives. This chapter is devoted almost exclusively to finding/computing derivatives. We will, however, take a look at a single application of derivatives in this chapter. We will be leaving most of the applications of derivatives that we will be discussing to the next chapter.

This chapter will start out with defining just what a derivative is as well as look at a couple of the main interpretations. In the process we will start to understand just how interconnected the main topics of first Calculus course are. In particular, we will see that, in theory, we can't do derivatives unless we can also do limits.

However, having said that we'll also see that using limits to compute derivatives can be a fairly long process that is prone to inadvertent errors if we get in a hurry and, in some cases, will be all but impossible to do. Therefore, after discussing the definition of the derivative we'll move off to looking at some formulas for computing derivatives that will allow us to avoid having to use limits to compute derivatives. Note however that won't mean that we can just forget all about using limits to compute derivatives. That is still something that will, on occasion, come up so we can't forget about that.

We will discuss formulas for the following functions.

- Functions involving polynomials, roots and more generally, terms involving variables raised to a power.
- Trigonometric functions.
- Exponential and Logarithm functions.
- Inverse Trigonometric functions.
- Hyperbolic functions.

We'll also see very quickly that while the formulas for the functions above are nice they won't actually allow us to differentiate just any function that involved them. So, we will also discuss the Product and Quotient Rules allowing us to differentiate, oddly enough, products and quotients involving the functions listed above. We will also take a long look at something called the Chain Rule which will again greatly expand the number of functions we can differentiate. In fact, the Chain Rule may be the most important of the formulas we discuss as easily the majority of derivatives will be taking eventually will involve the Chain Rule at least partially.

In addition we will also take a look at implicit differentiation. This will, again, expand the number of derivatives that we can find, including allowing us to find derivatives that we would not be able to find otherwise. Implicit differentiation will also allow us to look at the only application of derivatives that we will look at in this chapter, Related Rates. Related Rates problems will allow us to determine the rate of change of a quantity provided we know something about the rates of change for the other quantities in the problem.

We will also look at higher order derivatives. Or, in other words, we will take the derivative of a derivative and discuss an application of at least one of the higher order derivatives.

We will then close out the chapter with a quick discussion of Logarithmic Differentiation. Logarithmic Differentiation is an alternative method of differentiation that can be used instead of the Product and Quotient Rule (sometimes easier sometimes not...). More importantly logarithmic differentiation will allow us to differentiate a class of functions that none of the formulas we will have discussed in this chapter up to this point would allow us to differentiate.

The following sections are the assignment problems (no solutions available) for this material.

If you are looking for some practice problems (with solutions available) please check out the [Practice Problems](#). There you will find a set of problems that should give you quite a bit of practice.

3.1 The Definition of the Derivative

Use the definition of the derivative to find the derivative of the following functions.

1. $g(x) = 10$

2. $T(y) = -8$

3. $f(x) = 5x + 7$

4. $Q(t) = 1 - 12t$

5. $f(z) = z^2 + 3$

6. $R(w) = w^2 - 8w + 20$

7. $V(t) = 6t - t^2$

8. $Q(t) = 2t^2 - 8t + 10$

9. $g(z) = 1 + 10z - 7z^2$

10. $f(x) = 5x - x^3$

11. $Y(t) = 2t^3 + 9t + 5$

12. $Z(x) = 2x^3 - x^2 - x$

13. $f(t) = \frac{2}{t-3}$

14. $g(x) = \frac{x+2}{1-x}$

15. $Q(t) = \frac{t^2}{t+2}$

16. $f(w) = \sqrt{w+8}$

17. $V(t) = \sqrt{14+3t}$

18. $G(x) = \sqrt{2-5x}$

19. $Q(t) = \sqrt{1+4t}$

20. $f(x) = \sqrt{x^2+1}$

21. $W(t) = \frac{1}{\sqrt{t}}$

22. $g(x) = \frac{4}{\sqrt{1-x}}$

23. $f(x) = x + \sqrt{x}$

24. $f(x) = x + \frac{1}{x}$

3.2 Interpretation of the Derivative

For problems 1 - 3 use the graph of the function, $f(x)$, estimate the value of $f'(a)$ for the given values of a .

1.

(a) $a = -5$

(b) $a = 1$

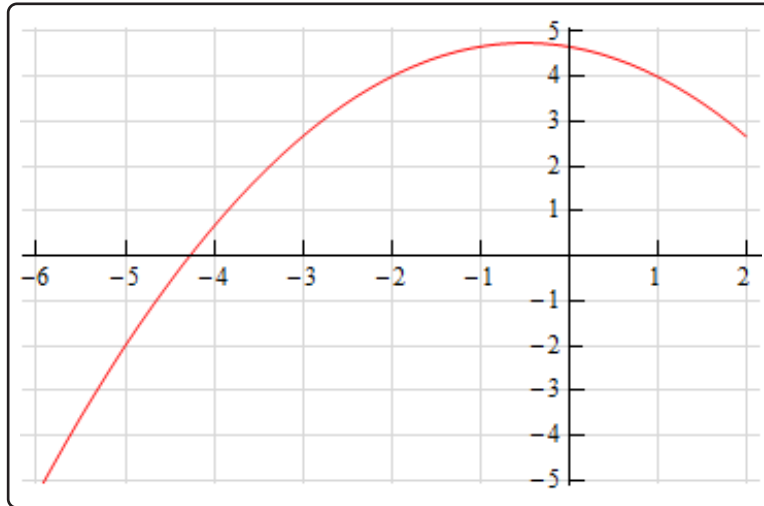

2.

(a) $a = -2$

(b) $a = 3$

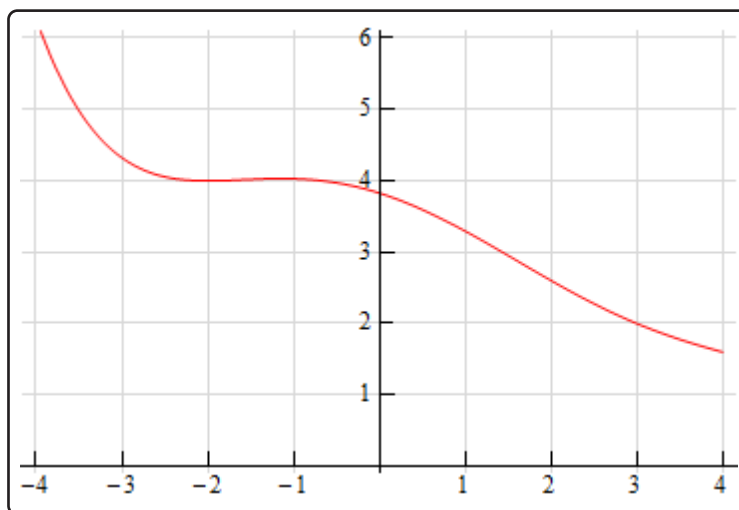

3.

(a) $a = -3$

(b) $a = 4$

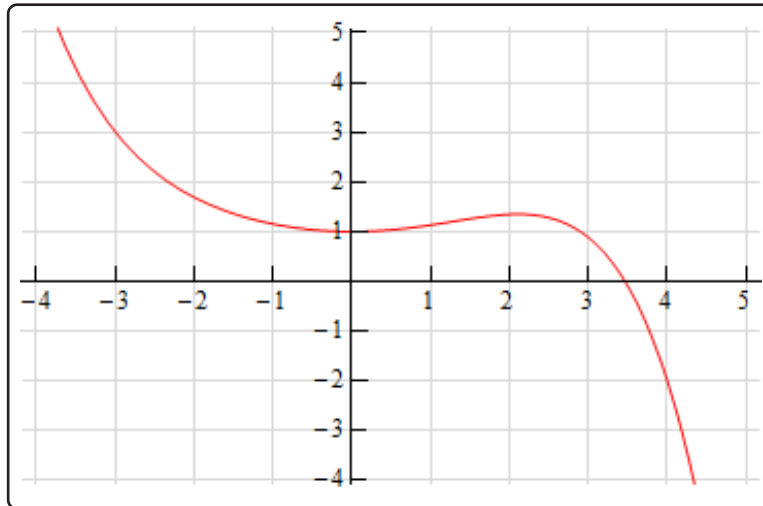

For problems 4 - 6 sketch the graph of a function that satisfies the given conditions.

4. $f(-7) = 5$, $f'(-7) = -3$, $f(4) = -1$, $f'(4) = 1$

5. $f(1) = 2$, $f'(1) = 4$, $f(6) = 2$, $f'(6) = 3$

6. $f(-1) = -9$, $f'(-1) = 0$, $f(2) = -1$, $f'(2) = 3$, $f(5) = 4$, $f'(5) = -1$

For problems 7 - 9 the graph of a function, $f(x)$, is given. Use this to sketch the graph of the derivative, $f'(x)$.

7.

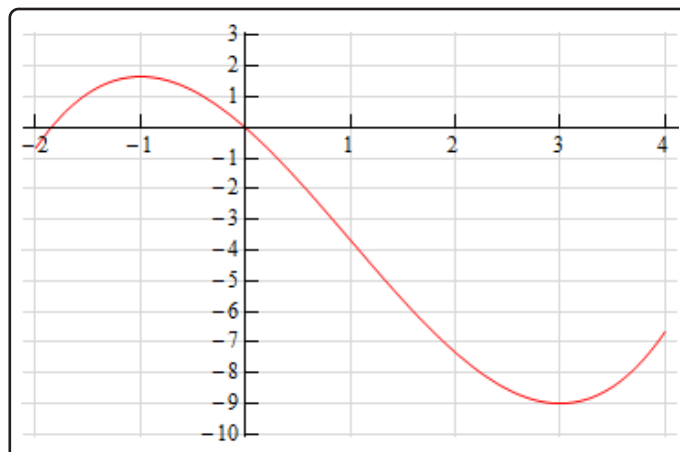

8.

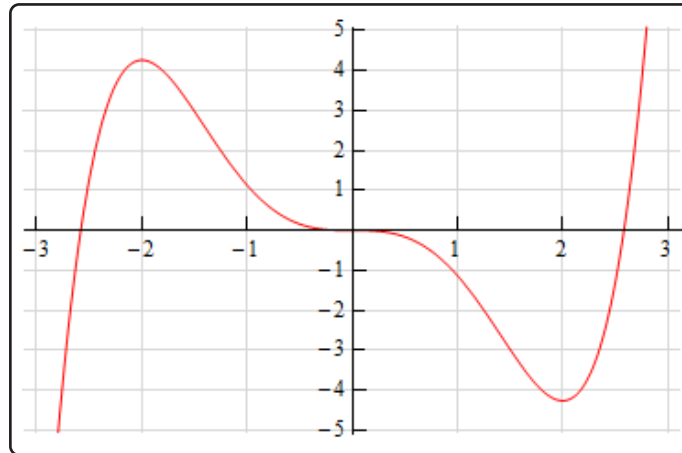

9.

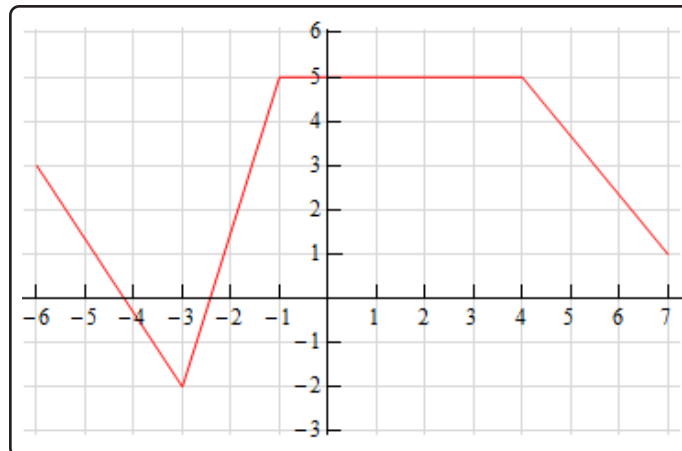

10. Answer the following questions about the function $g(z) = 1 + 10z - 7z^2$.

(a) Is the function increasing or decreasing at $z = 0$?

(b) Is the function increasing or decreasing at $z = 2$?

(c) Does the function ever stop changing? If yes, at what value(s) of z does the function stop changing?

11. What is the equation of the tangent line to $f(x) = 5x - x^3$ at $x = 1$.

12. The position of an object at any time t is given by $s(t) = 2t^2 - 8t + 10$.
- (a) Determine the velocity of the object at any time t .
 - (b) Is the object moving to the right or left at $t = 1$?
 - (c) Is the object moving to the right or left at $t = 4$?
 - (d) Does the object ever stop moving? If so, at what time(s) does the object stop moving?
13. Does the function $R(w) = w^2 - 8w + 20$ ever stop changing? If yes, at what value(s) of w does the function stop changing?
14. Suppose that the volume of air in a balloon for $0 \leq t \leq 6$ is given by $V(t) = 6t - t^2$.
- (a) Is the volume of air increasing or decreasing at $t = 2$?
 - (b) Is the volume of air increasing or decreasing at $t = 5$?
 - (c) Does the volume of air ever stop changing? If yes, at what times(s) does the volume stop changing?
15. What is the equation of the tangent line to $f(x) = 5x + 7$ at $x = -4$?
16. Answer the following questions about the function $Z(x) = 2x^3 - x^2 - x$.
- (a) Is the function increasing or decreasing at $x = -1$?
 - (b) Is the function increasing or decreasing at $x = 2$?
 - (c) Does the function ever stop changing? If yes, at what value(s) of x does the function stop changing?
17. Determine if the function $V(t) = \sqrt{14 + 3t}$ increasing or decreasing at the given points.
- (a) $t = 0$
 - (b) $t = 5$
 - (c) $t = 100$

18. Suppose that the volume of water in a tank for $t \geq 0$ is given by $Q(t) = \frac{t^2}{t+2}$.
- (a) Is the volume of water increasing or decreasing at $t = 0$?
 - (b) Is the volume of water increasing or decreasing at $t = 3$?
 - (c) Does the volume of water ever stop changing? If so, at what times(s) does the volume stop changing?
19. What is the equation of the tangent line to $g(x) = 10$ at $x = 16$?
20. The position of an object at any time t is given by $Q(t) = \sqrt{1+4t}$.
- (a) Determine the velocity of the object at any time t .
 - (b) Does the object ever stop moving? If so, at what time(s) does the object stop moving?
21. Does the function $Y(t) = 2t^3 + 9t + 5$ ever stop changing? If yes, at what value(s) of t does the function stop changing?

3.3 Differentiation Formulas

For problems 1 - 20 find the derivative of the given function.

1. $g(x) = 8 - 4x^3 + 2x^8$

2. $f(z) = z^{10} - 7z^5 + 2z^3 - z^2$

3. $y = 8x^4 - 10x^3 - 9x + 4$

4. $f(x) = 3x^{-4} + x^4 - 3x$

5. $R(t) = 9t^{10} + 8t^{-10} + 12$

6. $h(y) = 3y^{-6} - 8y^{-3} + 9y^{-1}$

7. $g(t) = t^{-7} + 2t^{-3} - 6t^{-2} + 8t^4 - 1$

8. $z = \sqrt[6]{x} - 7\sqrt[4]{x} + 3\sqrt{x}$

9. $f(x) = 7\sqrt[9]{x^4} - 2\sqrt[2]{x^7} + \sqrt[3]{x^4}$

10. $h(y) = 6\sqrt{y} + \sqrt[6]{y^5} + \frac{7}{\sqrt[9]{y^2}}$

11. $g(z) = \frac{4}{z^2} + \frac{1}{7z^5} - \frac{1}{2z}$

12. $y = \frac{2}{3t^9} + \frac{1}{7t^3} - 9t^2 - \sqrt{t^3}$

13. $W(x) = x^3 - \frac{1}{x^6} + \frac{1}{\sqrt[5]{x^2}}$

14. $g(w) = (w - 5)(w^2 + 1)$

15. $h(x) = \sqrt{x}(1 - 9x^3)$

16. $f(t) = (3 - 2t^3)^2$

17. $g(x) = (1 + 2x)(2 - x + x^2)$

18. $y = \frac{4 - 8x + 2x^2}{x}$

19. $Y(t) = \frac{t^4 - 2t^2 + 7t}{t^3}$

20. $S(w) = \frac{w^2(2 - w) + w^5}{3w}$

For problems 21 - 26 determine where, if anywhere, the function is not changing.

21. $f(x) = 2x^3 - 9x^2 - 108x + 14$

22. $u(t) = 45 + 300t^2 + 20t^3 - 3t^4$

23. $Q(t) = t^3 - 9t^2 + t - 10$

24. $h(w) = 2w^3 + 3w^2 + 4w + 5$

25. $g(x) = 9 + 8x^2 + 3x^3 - x^4$

26. $G(z) = z^2(z - 1)^2$

27. Find the tangent line to $f(x) = 3x^5 - 4x^2 + 9x - 12$ at $x = -1$.28. Find the tangent line to $g(x) = \frac{x^2 + 1}{x}$ at $x = 2$.29. Find the tangent line to $h(x) = 2\sqrt{x} - 8\sqrt[4]{x}$ at $x = 16$.30. The position of an object at any time t is given by $s(t) = 3t^4 - 44t^3 + 108t^2 + 20$.(a) Determine the velocity of the object at any time t .

(b) Does the position of the object ever stop changing?

(c) When is the object moving to the right and when is the object moving to the left?

31. The position of an object at any time t is given by $s(t) = 1 - 150t^3 + 45t^4 - 2t^5$.(a) Determine the velocity of the object at any time t .

(b) Does the position of the object ever stop changing?

(c) When is the object moving to the right and when is the object moving to the left?

32. Determine where the function $f(x) = 4x^3 - 18x^2 - 336x + 27$ is increasing and decreasing.33. Determine where the function $g(w) = w^4 + 2w^3 - 15w^2 - 9$ is increasing and decreasing.34. Determine where the function $V(t) = t^3 - 24t^2 + 192t - 50$ is increasing and decreasing.35. Determine the percentage of the interval $[-6, 4]$ on which $f(x) = 7 + 10x^3 - 5x^4 - 2x^5$ is increasing.36. Determine the percentage of the interval $[-5, 2]$ on which $f(x) = 3x^4 - 8x^3 - 144x^2$ is decreasing.

37. Is $h(x) = 3 - x + x^2 + 2x^3$ increasing or decreasing more on the interval $[-1, 1]$?
38. Determine where, if anywhere, the tangent line to $f(x) = 12x^2 - 9x + 3$ is parallel to the line $y = 1 - 7x$.
39. Determine where, if anywhere, the tangent line to $f(x) = 8 + 4x + x^2 - 2x^3$ is perpendicular to the line $y = -\frac{1}{4}x + \frac{8}{3}$.
40. Determine where, if anywhere, the tangent line to $f(x) = \sqrt[3]{x} - 8x$ is perpendicular to the line $y = 2x - 11$.
41. Determine where, if anywhere, the tangent line to $f(x) = \frac{13x}{9} + \frac{1}{x}$ is parallel to the line $y = x$.

3.4 Product and Quotient Rule

For problems 1 - 7 use the Product Rule or the Quotient Rule to find the derivative of the given function.

$$1. h(z) = (2 - \sqrt{z}) (3 + 8 \sqrt[3]{z^2})$$

$$2. f(x) = \left(x - \frac{2}{x}\right) (7 - 2x^3)$$

$$3. y = (x^2 - 5x + 1) (12 + 2x - x^3)$$

$$4. g(x) = \frac{\sqrt[3]{x}}{1 + x^2}$$

$$5. Z(y) = \frac{4y - y^2}{6 - y}$$

$$6. V(t) = \frac{1 - 10t + t^2}{5t + 2t^3}$$

$$7. f(w) = \frac{(1 - 4w)(2 + w)}{3 + 9w}$$

For problems 8 - 12 use the fact that $f(-3) = 12$, $f'(-3) = 9$, $g(-3) = -4$, $g'(-3) = 7$, $h(-3) = -2$ and $h'(-3) = 5$ determine the value of the indicated derivative.

$$8. (fg)'(-3)$$

$$9. \left(\frac{h}{g}\right)'(-3)$$

$$10. \left(\frac{fg}{h}\right)'(-3)$$

$$11. \text{ If } y = [x - f(x)] h(x) \text{ determine } \left.\frac{dy}{dx}\right|_{x=-3}.$$

$$12. \text{ If } y = \frac{1 - g(x)h(x)}{x + f(x)} \text{ determine } \left.\frac{dy}{dx}\right|_{x=-3}.$$

$$13. \text{ Find the equation of the tangent line to } f(x) = (8 - x^2)(1 + x + x^2) \text{ at } x = -2.$$

$$14. \text{ Find the equation of the tangent line to } f(x) = \frac{4 - x^3}{x + 2x^2} \text{ at } x = 1.$$

$$15. \text{ Determine where } g(z) = \frac{2 - z}{12 + z^2} \text{ is increasing and decreasing.}$$

16. Determine where $R(x) = (3 - x)(1 - 2x + x^2)$ is increasing and decreasing.
17. Determine where $h(t) = \frac{7t - t^2}{1 + 2t^2}$ is increasing and decreasing.
18. Determine where $f(x) = \frac{1 + x}{1 - x}$ is increasing and decreasing.
19. Derive the formula for the Product Rule for four functions.

$$(fghw)' = f'ghw + fg'hw + fgh'w + fghw'$$

3.5 Derivatives of Trig Functions

For problems 1 - 6 evaluate the given limit.

1. $\lim_{t \rightarrow 0} \frac{3t}{\sin(t)}$

2. $\lim_{w \rightarrow 0} \frac{\sin(9w)}{10w}$

3. $\lim_{\theta \rightarrow 0} \frac{\sin(2\theta)}{\sin(17\theta)}$

4. $\lim_{x \rightarrow -4} \frac{\sin(x+4)}{3x+12}$

5. $\lim_{x \rightarrow 0} \frac{\cos(x) - 1}{9x}$

6. $\lim_{z \rightarrow 0} \frac{\cos(8z) - 1}{2z}$

For problems 7 - 16 differentiate the given function.

7. $h(x) = x^4 - 9 \sin(x) + 2 \tan(x)$

8. $g(t) = 8 \sec(t) + \cos(t) - 4 \csc(t)$

9. $y = 6 \cot(w) - 8 \cos(w) + 9$

10. $f(x) = 8 \sec(x) \csc(x)$

11. $h(t) = 8 - t^9 \tan(t)$

12. $R(x) = 6 \sqrt[5]{x^2} + 8x \sin(x)$

13. $h(z) = 3z - \frac{\cos(z)}{z^3}$

14. $Y(x) = \frac{1 + \cos(x)}{1 - \sin(x)}$

15. $f(w) = 3w - \frac{\sec(w)}{1 + 9 \tan(w)}$

16. $g(t) = \frac{t \cot(t)}{t^2 + 1}$

17. Find the tangent line to $f(x) = 2 \tan(x) - 4x$ at $x = 0$.

18. Find the tangent line to $f(x) = x \sec(x)$ at $x = 2\pi$.
19. Find the tangent line to $f(x) = \cos(x) + \sec(x)$ at $x = \pi$.
20. The position of an object is given by $s(t) = 9 \sin(t) + 2 \cos(t) - 7$ determine all the points where the object is not changing.
21. The position of an object is given by $s(t) = 8t + 10 \sin(t)$ determine where in the interval $[0, 12]$ the object is moving to the right and moving to the left.
22. Where in the range $[-6, 6]$ is the function $f(z) = 3z - 8 \cos(z)$ is increasing and decreasing.
23. Where in the range $[-3, 5]$ is the function $R(w) = 7 \cos(w) - \sin(w) + 3$ is increasing and decreasing.
24. Where in the range $[0, 10]$ is the function $h(t) = 9 - 15 \sin(t)$ is increasing and decreasing.
25. Using the definition of the derivative prove that $\frac{d}{dx}(\cos(x)) = -\sin(x)$.
26. Prove that $\frac{d}{dx}(\sec(x)) = \sec(x) \tan(x)$.
27. Prove that $\frac{d}{dx}(\cot(x)) = -\csc^2(x)$.
28. Prove that $\frac{d}{dx}(\csc(x)) = -\csc(x) \cot(x)$.

3.6 Derivatives of Exponential and Logarithm Functions

For problems 1 - 12 differentiate the given function.

1. $g(z) = 10^z - 9^z$
2. $f(x) = 9 \log_4(x) + 12 \log_{11}(x)$
3. $h(t) = 6^t - 4e^t$
4. $R(x) = 20 \ln(x) + \log_{123}(x)$
5. $Q(t) = (t^2 - 6t + 3) e^t$
6. $y = v + 8^v 9^v$
7. $U(z) = \log_4(z) - z^6 \ln(z)$
8. $h(x) = \log_3(x) \log(x)$
9. $f(w) = \frac{1 - e^w}{1 + 7e^w}$
10. $f(t) = \frac{1 + 4 \ln(t)}{5t^3}$
11. $g(r) = \frac{r^2 + \log_7(r)}{7^r}$
12. $V(t) = \frac{t^4 e^t}{\ln(t)}$
13. Find the tangent line to $f(x) = (1 - 8x) e^x$ at $x = -1$.
14. Find the tangent line to $f(x) = 3x^2 \ln(x)$ at $x = 1$.
15. Find the tangent line to $f(x) = 3e^x + 8 \ln(x)$ at $x = 2$.
16. Determine if $U(y) = 4^y - 3e^y$ is increasing or decreasing at the following points.
(a) $y = -2$ **(b)** $y = 0$ **(c)** $y = 3$
17. Determine if $y(z) = \frac{z^2}{\ln(z)}$ is increasing or decreasing at the following points.
(a) $z = \frac{1}{2}$ **(b)** $z = 2$ **(c)** $z = 6$
18. Determine if $h(x) = x^2 e^x$ is increasing or decreasing at the following points.
(a) $x = -1$ **(b)** $x = 0$ **(c)** $x = 2$

3.7 Derivatives of Inverse Trig Functions

For each of the following problems differentiate the given function.

1. $f(x) = \sin(x) + 9\sin^{-1}(x)$

2. $C(t) = 5\sin^{-1}(t) - \cos^{-1}(t)$

3. $g(z) = \tan^{-1}(z) + 4\cos^{-1}(z)$

4. $h(t) = \sec^{-1}(t) - t^3\cos^{-1}(t)$

5. $f(w) = (w - w^2)\sin^{-1}(w)$

6. $y = (x - \cot^{-1}(x))(1 + \csc^{-1}(x))$

7. $Q(z) = \frac{z + 1}{\tan^{-1}(z)}$

8. $A(t) = \frac{1 + \sin^{-1}(t)}{1 - \cos^{-1}(t)}$

3.8 Derivatives of Hyperbolic Functions

For each of the following problems differentiate the given function.

1. $h(w) = w^2 - 3 \sinh(w)$

2. $g(x) = \cos(x) + \cosh(x)$

3. $H(t) = 3 \operatorname{csch}(t) + 7 \sinh(t)$

4. $A(r) = \tan(r) \tanh(r)$

5. $f(x) = e^x \cosh(x)$

6. $f(z) = \frac{\operatorname{sech}(z) + 1}{1 - z}$

7. $Q(w) = \frac{\operatorname{coth}(w)}{w + \sinh(w)}$

3.9 Chain Rule

For problems 1 - 51 differentiate the given function.

1. $g(x) = (3 - 8x)^{11}$
2. $g(z) = \sqrt[7]{9z^3}$
3. $h(t) = (9 + 2t - t^3)^6$
4. $y = \sqrt{w^3 + 8w^2}$
5. $R(v) = (14v^2 - 3v)^{-2}$
6. $H(w) = \frac{2}{(6 - 5w)^8}$
7. $f(x) = \sin(4x + 7x^4)$
8. $T(x) = \tan(1 - 2e^x)$
9. $g(z) = \cos(\sin(z) + z^2)$
10. $h(u) = \sec(u^2 - u)$
11. $y = \cot(1 + \cot(x))$
12. $f(t) = e^{1-t^2}$
13. $J(z) = e^{12z-z^6}$
14. $f(z) = e^{z+\ln(z)}$
15. $B(x) = 7^{\cos(x)}$
16. $z = 3^{x^2-9x}$
17. $R(z) = \ln(6z + e^z)$
18. $h(w) = \ln(w^7 - w^5 + w^3 - w)$
19. $g(t) = \ln(1 - \csc(t))$
20. $f(v) = \tan^{-1}(3 - 2v)$
21. $h(t) = \sin^{-1}(9t)$
22. $A(t) = \cos(t) - \sqrt[6]{1 - \sin(t)}$
23. $H(z) = \ln(6z) - 4 \sec(z)$

24. $f(x) = \tan^4(x) + \tan(x^4)$

25. $f(u) = e^{4u} - 6e^{-u} + 7e^{u^2-8u}$

26. $g(z) = \sec^8(z) + \sec(z^8)$

27. $k(w) = (w^4 - 1)^5 + \sqrt{2 + 9w}$

28. $h(x) = \sqrt[3]{x^2 - 5x + 1} + (9x + 4)^{-7}$

29. $T(x) = (2x^3 - 1)^5(5 - 3x)^4$

30. $w = (z^2 + 4z) \sin(1 - 2z)$

31. $Y(t) = t^8 \cos^4(t)$

32. $f(x) = \sqrt{6 - x^4} \ln(10x + 3)$

33. $A(z) = \sec(4z) \tan(z^2)$

34. $h(v) = \sqrt{5v} + \ln(v^4) e^{6+9v}$

35. $f(x) = \frac{e^{x^2+8x}}{\sqrt{x^4+7}}$

36. $g(x) = \frac{(4x+1)^3}{(x^2-x)^6}$

37. $g(t) = \frac{\csc(1-t)}{1+e^{-t}}$

38. $V(z) = \frac{\sin^2(z)}{1+\cos(z^2)}$

39. $U(w) = \ln(e^w \cos(w))$

40. $h(t) = \tan((5-t^2) \ln(t))$

41. $z = \ln\left(\frac{3+x}{2-x^2}\right)$

42. $g(v) = \sqrt{\frac{e^v}{7+2v}}$

43. $f(x) = \sqrt{x^2 + \sqrt{1+4x}}$

44. $u = (6 + \cos(8w))^5$

45. $h(z) = (7z - z^2 + e^{5z^2+z})^{-4}$

46. $A(y) = \ln(7y^3 + \sin^2(y))$
47. $g(x) = \csc^6(8x)$
48. $V(w) = \sqrt[4]{\cos(9 - w^2) + \ln(6w + 5)}$
49. $h(t) = \sin(t^3 e^{-6t})$
50. $B(r) = (e^{\sin(r)} - \sin(e^r))^8$
51. $f(z) = \cos^2(1 + \cos^2(z))$
52. Find the tangent line to $f(x) = (2 - 4x^2)^5$ at $x = 1$.
53. Find the tangent line to $f(x) = e^{2x+4} - 8 \ln(x^2 - 3)$ at $x = -2$.
54. Determine where $A(t) = t^3(9 - t)^4$ is increasing and decreasing.
55. Is $h(x) = (2x + 1)^4(2 - x)^5$ increasing or decreasing more in the interval $[-2, 3]$?
56. Determine where $U(w) = 3 \cos\left(\frac{w}{2}\right) + w - 3$ is increasing and decreasing in the interval $[-10, 10]$.
57. If the position of an object is given by $s(t) = 4 \sin(3t) - 10t + 7$. Determine where, if anywhere, the object is not moving in the interval $[0, 4]$.
58. Determine where $f(x) = 6 \sin(2x) - 7 \cos(2x) - 3$ is increasing and decreasing in the interval $[-3, 2]$.
59. Determine where $H(w) = (w^2 - 1)e^{2-w^2}$ is increasing and decreasing.
60. What percentage of $[-3, 5]$ is the function $g(z) = e^{z^2-8} + 3e^{1-2z^2}$ decreasing?
61. The position of an object is given by $s(t) = \ln(2t^3 - 21t^2 + 36t + 200)$. During the first 10 hours of motion (assuming the motion starts at $t = 0$) what percentage of the time is the object moving to the right?
62. For the function $f(x) = 1 - \frac{x}{2} - \ln(2 + 9x - x^2)$ determine each of the following.
- (a) The interval on which the function is defined.
- (b) Where the function is increasing and decreasing.

3.10 Implicit Differentiation

For problems 1 - 6 do each of the following.

- (a) Find y' by solving the equation for y and differentiating directly.
- (b) Find y' by implicit differentiation.
- (c) Check that the derivatives in (a) and (b) are the same.

1. $x^2y^9 = 2$

2. $\frac{6x}{y^7} = 4$

3. $1 = x^4 + 5y^3$

4. $8x - y^2 = 3$

5. $4x - 6y^2 = xy^2$

6. $\ln(xy) = x$

For problems 7 - 21 find y' by implicit differentiation.

7. $y^2 - 12x^3 = 8y$

8. $3y^7 + x^{10} = y^{-2} - 6x^3 + 2$

9. $y^{-3} + 4x^{-1} = 8y^{-1}$

10. $10x^4 - y^{-6} = 7y^3 + 4x^{-3}$

11. $\sin(x) + \cos(y) = e^{4y}$

12. $x + \ln(y) = \sec(y)$

13. $y^2(4 - x^2) = y^7 + 9x$

14. $6x^{-2} - x^3y^2 + 4x = 0$

15. $8xy + 2x^4y^{-3} = x^3$

16. $yx^3 - \cos(x)\sin(y) = 7x$

17. $e^x \cos(y) + \sin(xy) = 9$

18. $x^2 + \sqrt{x^3 + 2y} = y^2$

19. $\tan(3x + 7y) = 6 - 4x^{-1}$

20. $e^{x^2+y^2} = e^{x^2y^2} + 1$

21. $\sin\left(\frac{x}{y}\right) + x^3 = 2 - y^4$

For problems 22 - 24 find the equation of the tangent line at the given point.

22. $3x + y^2 = x^2 - 19$ at $(-4, 3)$

23. $x^2y = y^2 - 6x$ at $(2, 6)$

24. $2 \sin(x) \cos(y) = 1$ at $\left(\frac{\pi}{4}, -\frac{\pi}{4}\right)$

For problems 25 - 27 determine if the function is increasing, decreasing or not changing at the given point.

25. $x^2 - y^3 = 4y + 9$ at $(2, -1)$

26. $e^{1-x}e^{y^2} = x^3 + y$ at $(1, 0)$

27. $\sin(\pi - x) + y^2 \cos(x) = y$ at $\left(\frac{\pi}{2}, 1\right)$

For problems 28 - 31 assume that $x = x(t)$, $y = y(t)$ and $z = z(t)$ and differentiate the given equation with respect to t .

28. $x^4 - 6z = 3 - y^2$

29. $xy^4 = y^2z^3$

30. $z^7e^{6y} = (y^2 - 8x)^{10} + z^{-4}$

31. $\cos(z^2x^3) + \sqrt{y^2 + x^2} = 0$

3.11 Related Rates

1. In the following assume that x and y are both functions of t . Given $x = 3$, $y = 2$ and $y' = 7$ determine x' for the following equation.

$$x^3 - y^4 = x^2y - 7$$

2. In the following assume that x and y are both functions of t . Given $x = \frac{\pi}{6}$, $y = -4$ and $x' = 12$ determine y' for the following equation.

$$x^2 (y^2 - 16) - 6 \cos (2x) = 1 + y$$

3. In the following assume that x , y and z are all functions of t . Given $x = -1$, $y = 8$, $z = 2$, $x' = -4$ and $y' = 7$ determine z' for the following equation.

$$x^4 + \frac{y}{z} = 2x^2z^2 - 3$$

4. In the following assume that x , y and z are all functions of t . Given $x = -2$, $y = 3$, $z = 4$, $y' = 6$ and $z' = 0$ determine x' for the following equation.

$$xy^2z^2 = x^3 - z^4 - 8y$$

5. The sides of a square are increasing at a rate of 10 cm/sec. How fast is the area enclosed by the square increasing when the area is 150 cm².
6. The sides of an equilateral triangle are decreasing at a rate of 3 in/hr. How fast is the area enclosed by the triangle decreasing when the sides are 2 feet long?
7. A spherical balloon is being filled in such a way that the surface area is increasing at a rate of 20 cm²/sec when the radius is 2 meters. At what rate is air being pumped in the balloon when the radius is 2 meters?
8. A cylindrical tank of radius 2.5 feet is being drained of water at a rate of 0.25 ft³/sec. How fast is the height of the water decreasing?

9. A hot air balloon is attached to a spool of rope that is 125 feet away from the balloon when it is on the ground. The hot air balloon rises straight up in such a way that the length of rope increases at a rate of 15 ft/sec. How fast is the hot air balloon rising 20 seconds after it lifts off?

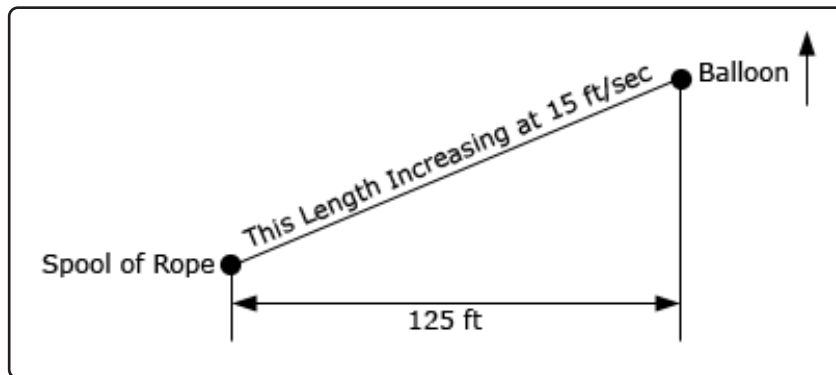

10. A rock is dropped straight off a bridge that is 50 meters above the ground and falls at a speed of 10 m/sec. Another person is 7 meters away on the same bridge. At what rate is the distance between the rock and the second person increasing just as the rock hits the ground?

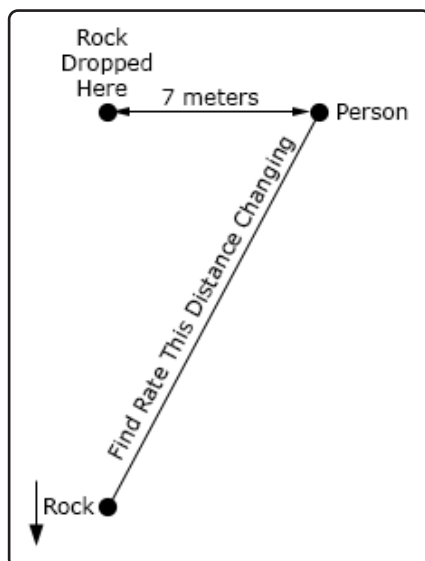

11. A person is 550 meters away from a road and there is a car that is initially 800 meters away approaching the person at a speed of 45 m/sec. At what rate is the distance between the person and the car changing **(a)** 5 seconds after the start, **(b)** when the car is directly in front of the person and **(c)** 10 seconds after the car has passed the person.

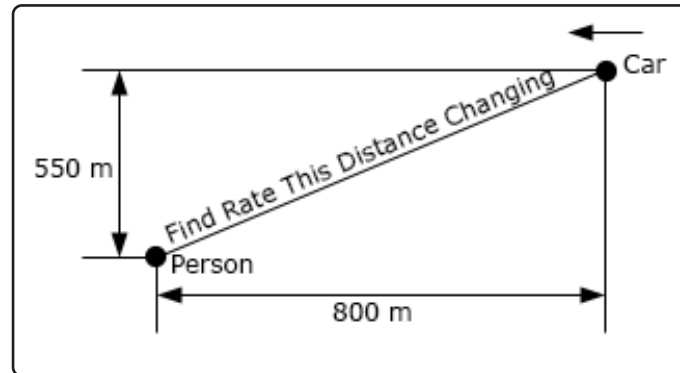

12. Two cars are initially 1200 miles apart. At the same time Car A starts driving at 35 mph to the east while Car B starts driving at 55 mph to the north (see sketch below for this initial setup). At what rate is the distance between the two cars changing after **(a)** 5 hours of travel, **(b)** 20 hours of travel and **(c)** 40 hours of travel?

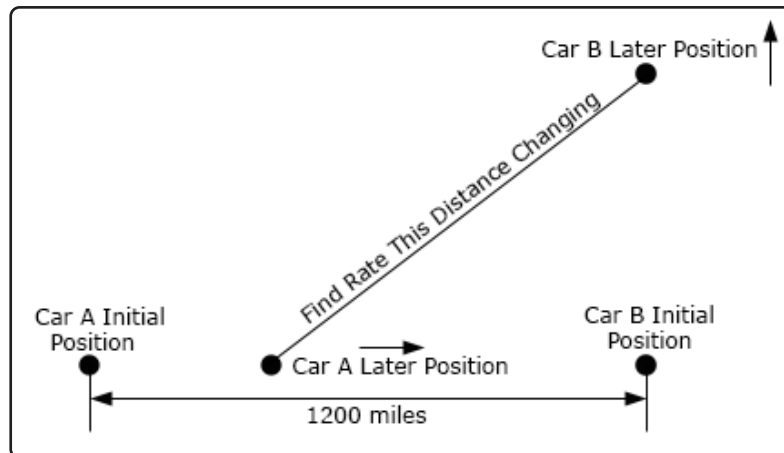

13. Repeat problem 12 above except for this problem assume that Car A starts traveling 4 hours after Car B starts traveling. For parts **(a)**, **(b)** and **(c)** assume that these are travel times for Car B.

14. Two people are on a city block. See the sketch below for placement and distances. Person A is on the northeast corner and Person B is on the southwest corner. Person A starts walking towards the southeast corner at a rate of 3 ft/sec. Four seconds later Person B starts walking towards the southeast corner at a rate of 2 ft/sec. At what rate is the distance between them changing (a) 10 seconds after Person A starts walking and (b) after Person A has covered half the distance?

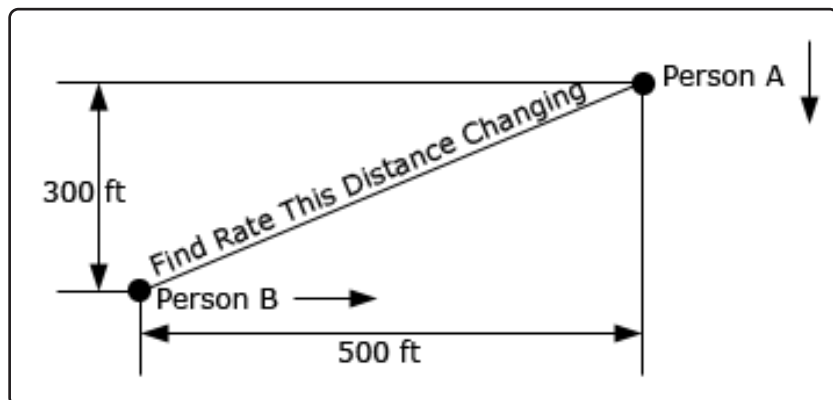

15. A person is standing 75 meters away from a kite and has a pool of string attached to the kite. The kite starts to rise straight up in the air at a rate of 2 m/sec and at the same time the person starts to move towards the kites launch point at a rate of 0.75 m/sec. Is the length string increasing or decreasing after (a) 4 seconds and (b) 20 seconds.
16. A person lights the fuse on a model rocket and starts to move away from the rocket at a rate of 3 ft/sec. Five seconds after lighting the fuse the rocket launches straight up into the air at a rate of 10 ft/sec. Is the distance between the person and the rocket increasing or decreasing (a) 6 seconds after launch and (b) 12 seconds after launch?

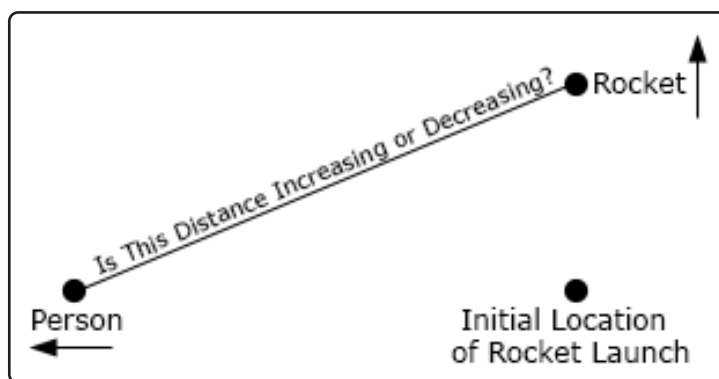

17. A light is on a pole and is being lowered towards the ground at a rate of 9 in/sec. A 6 foot tall person is on the ground and 8 feet away from the pole. At what rate is the persons shadow increasing then the light is 15 feet above the ground?

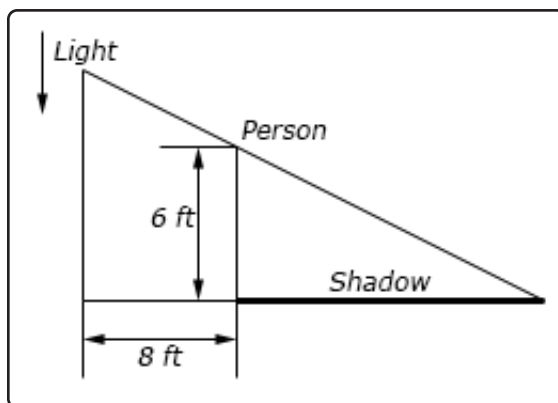

18. A light is fixed on a wall 10 meters above the floor. Twelve meters away from the wall a pole is being raised straight up at a rate of 45 cm/sec. When the pole is 6 meters tall at what rate is the tip of the shadow moving (a) away from the pole and (b) away from the wall? Note the sketch below is not to scale...

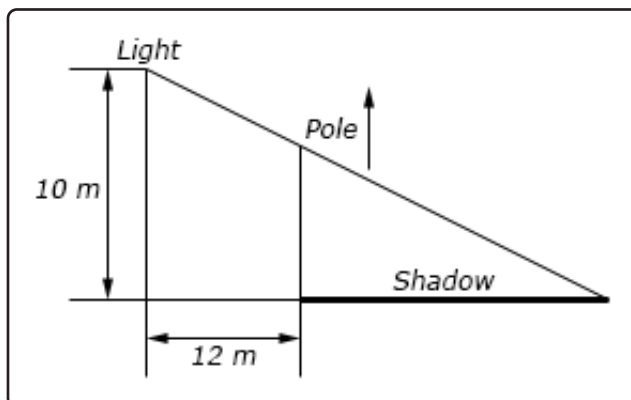

19. A light is on the top of a 15 foot tall pole. A 5 foot tall person starts at the pole and moves away from the pole at a rate of 2.5 ft/sec. After moving for 8 seconds at what rate is the tip of the shadow moving (a) away from the person and (b) away from the pole?

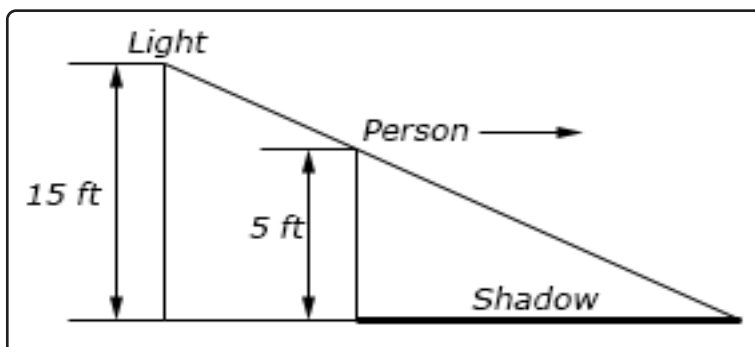

20. A tank of water is in the shape of a cone (assume the “point” of the cone is pointing downwards) and is leaking water at a rate of $35 \text{ cm}^3/\text{sec}$. The base radius of the tank is 1 meter and the height of the tank is 2.5 meters. When the depth of the water is 1.25 meters at what rate is the **(a)** depth changing and **(b)** the radius of the top of the water changing?

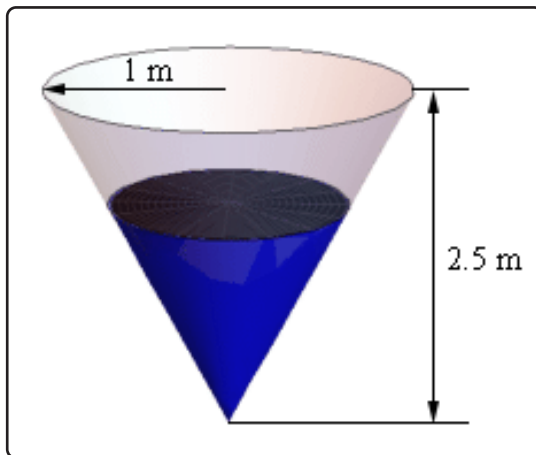

21. A trough of water is 20 meters in length and its ends are in the shape of an isosceles triangle whose width is 7 meters and height is 10 meters. Assume that the two equal length sides of the triangle are the sides of the water tank and the other side of the triangle is the top of the tank and is parallel to the ground. Water is being pumped into the tank at a rate of $2 \text{ m}^3/\text{min}$. When the water is 6 meters deep at what rate is **(a)** depth changing and **(b)** the width of the top of the water changing? Note the sketch below is not to scale...

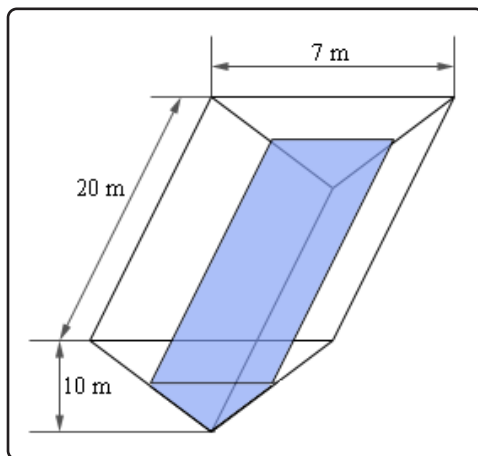

22. A trough of water is 9 feet long and its ends are in the shape of an equilateral triangle whose sides are 1.5 feet long. Assume that the top of the tank is parallel to the ground. If water is being pumped out of the tank at a rate of $2 \text{ ft}^3/\text{s}$ at what rate is the depth of the water changing when the depth is 0.75 feet?

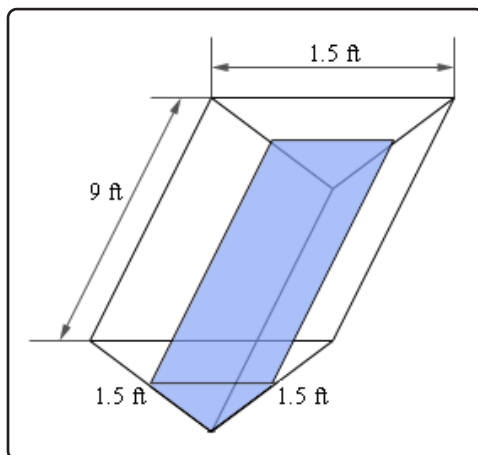

23. The angle of elevation (depression) is the angle formed by a horizontal line and a line joining the observer's eye to an object above (below) the horizontal line. Two people are on the roof of buildings separated by a 25 foot wide road. Person A is 100 feet above Person B and drops a rock off the roof of their building and it falls at a rate of $3 \text{ ft}/\text{sec}$. The sketches below are not to scale....

- (a) At what rate is the angle of elevation changing as Person B watches the rock fall when the rock is 35 feet above Person B?

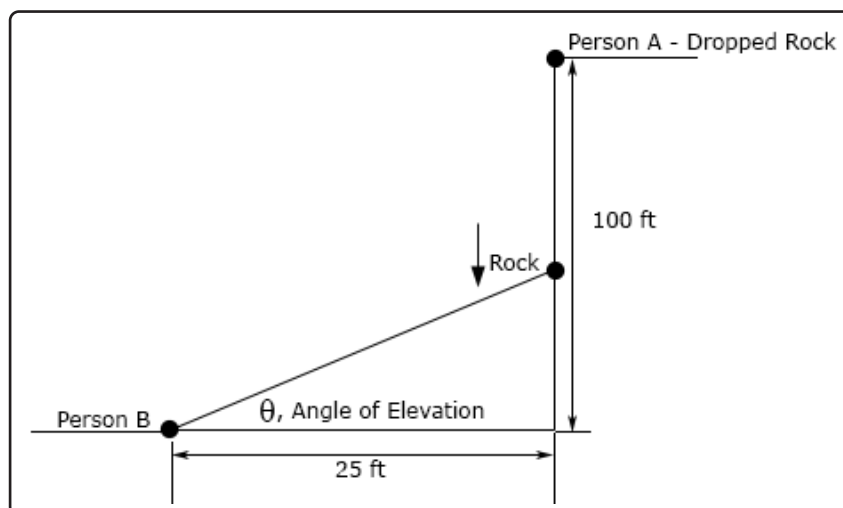

- (b) At what rate is the angle of depression changing as Person B watches the rock fall when the rock is 65 feet below Person B? See figure on next page.

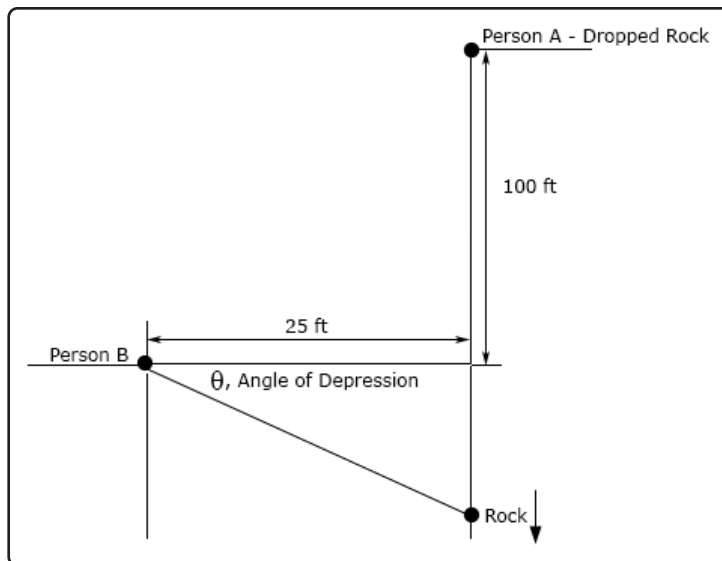

24. The angle of elevation is the angle formed by a horizontal line and a line joining the observer's eye to an object above the horizontal line. A person is standing 15 meters away from a building and watching an outside elevator move down the face of the building. When the angle of elevation is 1 radians it is changing at a rate of 0.15 radians/sec. At this point in time what is the speed of the elevator?

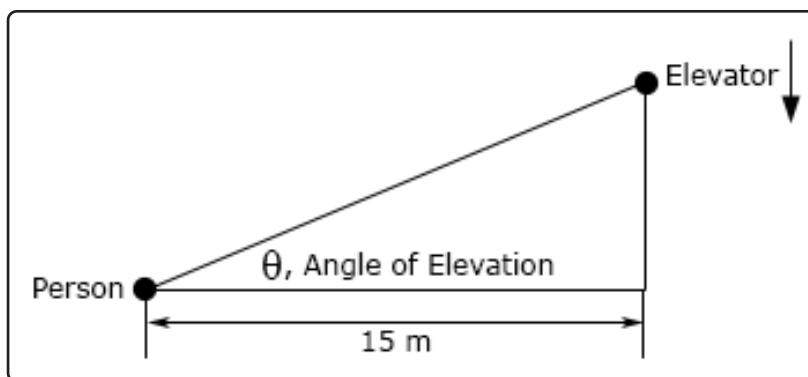

25. The angle of elevation is the angle formed by a horizontal line and a line joining the observer's eye to an object above the horizontal line. A person is 24 feet away from a building and watching an outside elevator move up the face of the building. The elevator is moving up at a rate of 4 ft/sec and the person is moving towards the building at a rate of 0.75 ft/sec. Assuming that the elevator started moving from the ground at the same time that the person started walking is the angle of elevation increasing or decreasing after 10 seconds?

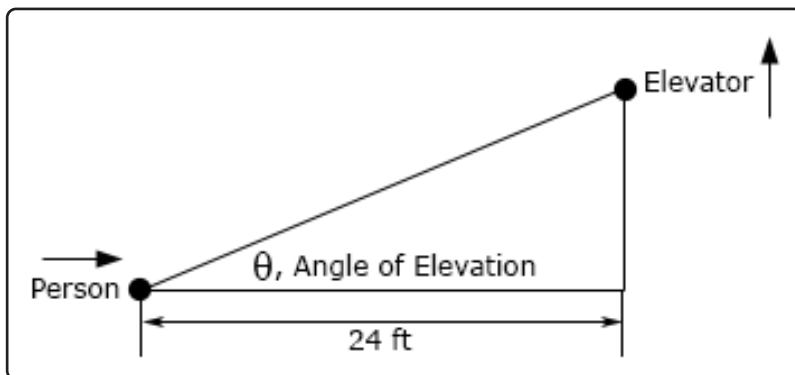

3.12 Higher Order Derivatives

For problems 1 - 9 determine the fourth derivative of the given function.

1. $f(z) = z^8 + 2z^6 - 7z^4 + 20z^2 - 3$

2. $y = 6t^4 - 5t^3 + 4t^2 - 3t + 2$

3. $V(t) = 6t^{-2} + 7t^{-3} - t^{-4}$

4. $g(x) = \frac{3}{x} - \frac{1}{4x^3} + \frac{3}{2x^5}$

5. $h(x) = 8\sqrt{x} - \sqrt[3]{x} + 5\sqrt[4]{x^9}$

6. $h(y) = \sqrt[3]{y^2} - \frac{32}{\sqrt[4]{y}} + \frac{1}{3\sqrt[5]{y^5}}$

7. $y = 9\sin(z) - \sin(4z) + 7\cos\left(\frac{2x}{3}\right)$

8. $R(x) = 2e^{-x} - 3e^{1+8x} + 9\ln(6x)$

9. $f(t) = \ln(t^6) - \cos(4t) + 9\sin(2t) + e^{7t}$

For problems 10 - 20 determine the second derivative of the given function.

10. $Q(w) = \cos(2 - 7w^2)$

11. $f(z) = \sin(1 + e^{2x})$

12. $y = \tan(3x)$

13. $z = \csc(8w)$

14. $f(u) = e^{4u^2+9u}$

15. $h(x) = \ln(x^2 - 3x)$

16. $g(z) = \ln(3 + \cos(z))$

17. $f(x) = \frac{1}{\sqrt{6x + x^4}}$

18. $f(x) = [3\sin(x) + 8\cos(2x)]^{-3}$

19. $f(t) = \sin^3(2t)$

20. $A(w) = \tan^4(w)$

For problems 21 - 23 determine the third derivative of the given function.

21. $g(x) = \sec(3x)$

22. $y = e^{1-2t^3}$

23. $h(w) = \cos(w - w^2)$

For problems 24 - 27 determine the second derivative of the given function.

24. $6y - y^2 = 3x^4 + 9x$

25. $y^3 - 4x^2 = 11x - 2y^2$

26. $e^y + 4x = y^3 - 1$

27. $y \cos(x) = 3 + 4y^2$

3.13 Logarithmic Differentiation

For problems 1 - 6 use logarithmic differentiation to find the first derivative of the given function.

1. $h(x) = x^8 \cos(3x) (6 + 3x^2)^4$

2. $f(w) = \sqrt{4 + 2w - 9w^2} \sqrt[5]{7w + 2w^3 + w^5}$

3. $h(z) = \frac{(1 + 7z^2)^3}{(2 + 3z + 4z^2)^4}$

4. $g(x) = \frac{\sqrt{1 + \sin(2x)}}{2x - \tan(x)}$

5. $h(t) = \frac{(9 - 3t)^{10}}{t^2 \sin(7t)}$

6. $y = \frac{3 + 8x}{(1 + 2x^2)^4} \frac{\cos(1 - x)}{(5x + x^2)^7}$

For problems 7 - 10 find the first derivative of the given function.

7. $y = x^{\ln(x)}$

8. $R(t) = [\sin(4t)]^{6t}$

9. $h(w) = (6 - w^2)^{2+8w+w^3}$

10. $g(z) = z^2[3 + z]^{1-z^2}$

4 Derivative Applications

In the previous chapter we focused almost exclusively, with the exception of Related Rates, on the computation and interpretation of derivatives. In this chapter will focus on applications of derivatives and it is important to always remember that we didn't spend a whole chapter talking about how to compute derivatives just to be talking about them. Each of the applications here will require us to compute at least one derivative and that computation will often be the very first step in the problem. So, if you are rusty with your differentiation skills you will need to go back to the previous chapter and scrap some of that rust off, so to speak, or you will find yourself struggling a lot in this chapter.

There are quite a few important applications to derivatives but almost all of them require the use of something called a critical point. So, we will first need to define just what a critical point is and make sure we are comfortable with finding critical points.

Once we have a good understanding of critical points we will turn our focus to the first application that we'll be spending quite bit of time on in this chapter. Namely, how we can use derivatives to find some important information about a function. We already know how to determine if a function is increasing or decreasing as we discussed that and worked a few problems on that in the last chapter. We will work some more problems involving increasing and decreasing functions to make sure we are clear on how that works. As we know from the last chapter we use the first derivative to determine where a function is increasing and decreasing. So we will then move on to see what the second derivative can tell us about a function. As we will see the second derivative can be used to determine the concavity of a function. The concavity of a function gives, in some way, the "curvature" of a function.

Once we have discussed all the information that derivatives can tell us about a function we'll use that information to get a sketch of the graph of a function without any kind of computational aid outside of occasionally needing a calculator to compute the value of the function at a few points. As we'll see we will often get a fairly good sketch of the graph from just this information.

The other topic that we will focus on in this chapter will be optimizing functions. By optimizing a function we mean finding the minimum and maximum value that a function can take. In addition, we will, on occasion, include a constraint on the function we are trying to optimize. The constraint will be an additional equation that the variable(s) in the function we are optimizing must also satisfy.

We will also take a quick look at a couple of other applications. These will include linear approximations (*i.e.* find a linear function that can approximate the function for at least a range of variables),

Chapter 4 : Derivative Applications

Newton's Method (*i.e.* approximating the solution to an equation) as well as a couple of applications of derivatives to some business applications.

We will also briefly revisit limits to discuss L'Hospital's Rule. This is a method of computing some limits of functions that are of "indeterminate form" (defined later) that we cannot, at this point, compute. A valid question is why did we not discuss L'Hospital's Rule back in the Limits chapter? That is a valid question and it has a simple answer. We couldn't discuss L'Hospital's Rule until this point because it involved taking some derivatives which we (clearly) did not yet know when we first looked at limits.

The following sections are the assignment problems (no solutions available) for this material.

If you are looking for some practice problems (with solutions available) please check out the [Practice Problems](#). There you will find a set of problems that should give you quite a bit practice.

4.1 Rates of Change

As noted in the text for this section the purpose of this section is only to remind you of certain types of applications that were discussed in the previous chapter. As such there aren't any problems written for this section. Instead here is a list of links (note that these will only be active links in the web version and not the pdf version) to problems from the relevant sections from the previous chapter.

Each of the following sections has a selection of increasing/decreasing problems towards the bottom of the problem set.

[Differentiation Formulas](#)

[Product & Quotient Rules](#)

[Derivatives of Trig Functions](#)

[Derivatives of Exponential and Logarithm Functions](#)

[Chain Rule](#)

Related Rates problems are in the [Related Rates](#) section.

4.2 Critical Points

For problems 1 - 43 determine the critical points of each of the following functions. Note that a couple of the problems involve equations that may not be easily solved by hand and as such may require some computational aids. These are marked are noted below.

1. $R(x) = 8x^3 - 18x^2 - 240x + 2$

2. $f(z) = 2z^4 - 16z^3 + 20z^2 - 7$

3. $g(z) = 8 - 12z^5 - 25z^6 + \frac{90}{7}z^7$

4. $g(t) = 3t^4 - 20t^3 - 132t^2 + 672t - 4$

Note : Depending upon your factoring skills this may require some computational aids.

5. $h(x) = 10x^2 - 15x^3 + \frac{15}{2}x^4 - x^5$

Note : Depending upon your factoring skills this may require some computational aids.

6. $P(w) = w^3 - 4w^2 - 7w - 1$

7. $A(t) = 7t^3 - 3t^2 + t - 15$

8. $a(t) = 4 - 2t^2 - 6t^3 - 3t^4$

9. $f(x) = 3x^4 - 20x^3 + 6x^2 + 120x + 5$

Note : This problem will require some computational aids.

10. $h(v) = v^5 + v^4 + 10v^3 - 15$

11. $g(z) = (z - 3)^5(2z + 1)^4$

12. $R(q) = (q + 2)^4(q^2 - 8)^2$

13. $f(t) = (t - 2)^3(t^2 + 1)^2$

14. $f(w) = \frac{w^2 + 2w + 1}{3w - 5}$

15. $h(t) = \frac{3 - 4t}{t^2 + 1}$

16. $R(y) = \frac{y^2 - y}{y^2 + 3y + 8}$

17. $Y(x) = \sqrt[3]{x - 7}$

18. $f(t) = (t^3 - 25t)^{\frac{2}{3}}$

19. $h(x) = \sqrt[5]{x} (2x + 8)^2$

20. $Q(w) = (6 - w^2) \sqrt[3]{w^2 - 4}$

21. $Q(t) = 7 \sin\left(\frac{t}{4}\right) - 2$

22. $g(x) = 3 \cos(2x) - 5x$

23. $f(x) = 7 \cos(x) + 2x$

24. $h(t) = 6 \sin(2t) + 12t$

25. $w(z) = \cos^3\left(\frac{z}{5}\right)$

26. $U(z) = \tan(z) - 4z$

27. $h(x) = x \cos(x) - \sin(x)$

28. $h(x) = 2 \cos(x) - \cos(2x)$

29. $f(w) = \cos^2(w) - \cos^4(w)$

30. $F(w) = e^{14w+3}$

31. $g(z) = z^2 e^{1-z}$

32. $A(x) = (3 - 2x) e^{x^2}$

33. $P(t) = (6t + 1) e^{8t-t^2}$

34. $f(x) = e^{3+x^2} - e^{2x^2-4}$

35. $f(z) = e^{z^2-4z} + e^{8z-2z^2}$

36. $h(y) = e^{6y^3-8y^2}$

37. $g(t) = e^{2t^3+4t^2-t}$

38. $Z(t) = \ln(t^2 + t + 3)$

39. $G(r) = r - \ln(r^2 + 1)$

40. $A(z) = 2 - 6z + \ln(8z + 1)$

41. $f(x) = x - 4 \ln(x^2 + x + 2)$

42. $g(x) = \ln(4x + 2) - \ln(x + 4)$

43. $h(t) = \ln(t^2 - t + 1) + \ln(4 - t)$

44. The graph of some function, $f(x)$, is shown. Based on the graph, estimate the location of all the critical points of the function.

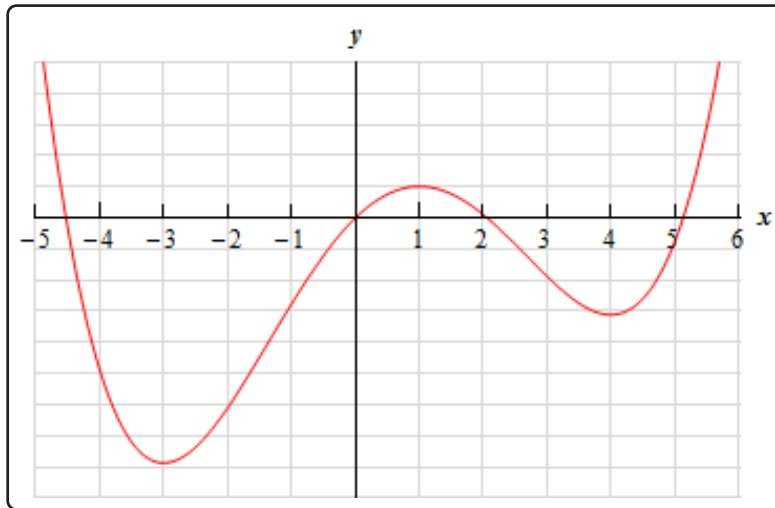

45. The graph of some function, $f(x)$, is shown. Based on the graph, estimate the location of all the critical points of the function.

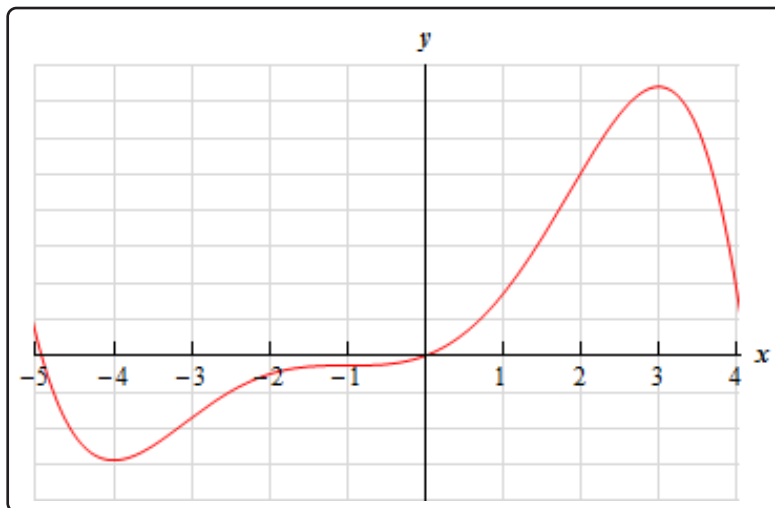

46. The graph of some function, $f(x)$, is shown. Based on the graph, estimate the location of all the critical points of the function.

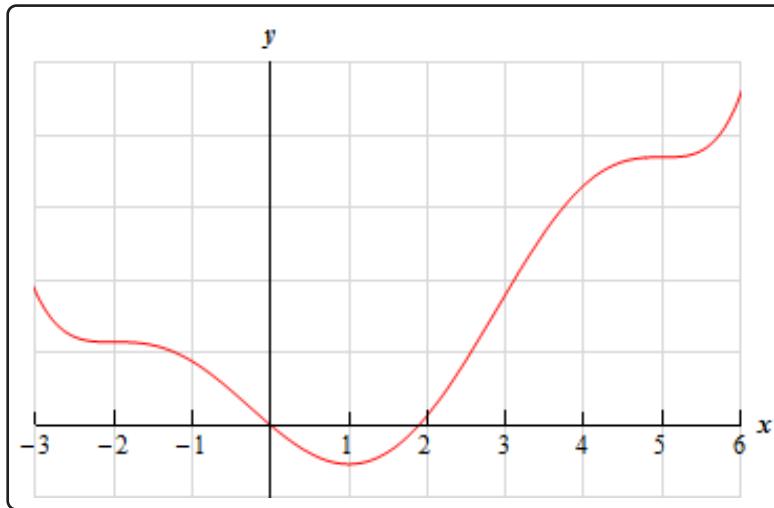

4.3 Minimum and Maximum Values

1. Below is the graph of some function, $f(x)$. Identify all of the relative extrema and absolute extrema of the function.

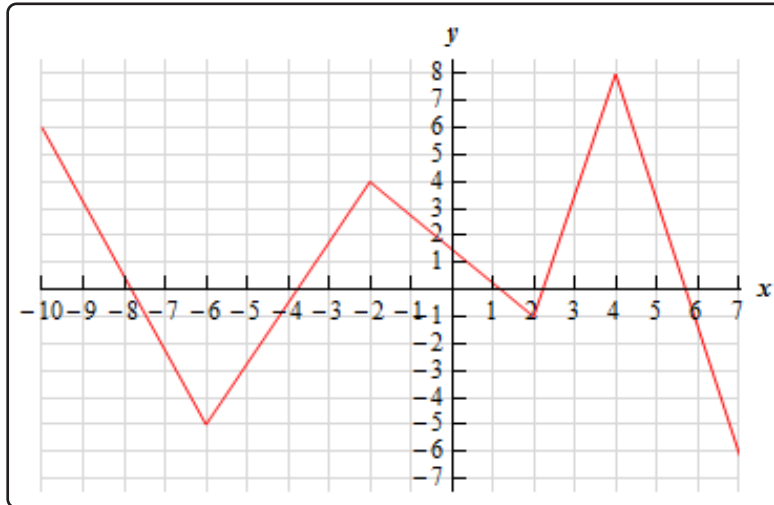

2. Below is the graph of some function, $f(x)$. Identify all of the relative extrema and absolute extrema of the function.

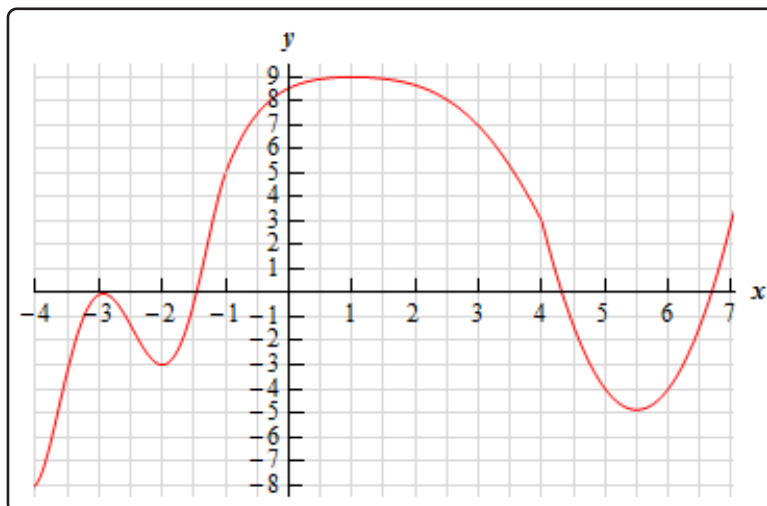

3. Below is the graph of some function, $f(x)$. Identify all of the relative extrema and absolute extrema of the function.

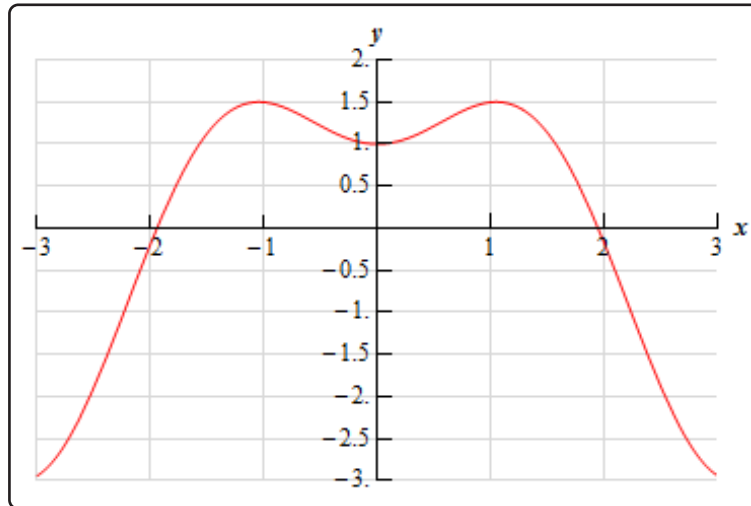

4. Below is the graph of some function, $f(x)$. Identify all of the relative extrema and absolute extrema of the function.

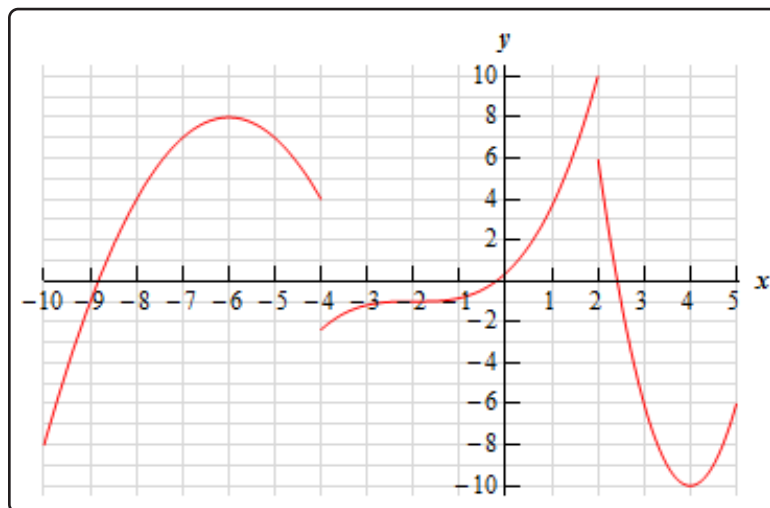

5. Sketch the graph of $f(x) = 3 - \frac{1}{2}x$ and identify all the relative extrema and absolute extrema of the function on each of the following intervals.

(a) $(-\infty, \infty)$

(b) $[-3, 2]$

(c) $[-4, 1]$

(d) $(0, 5)$

6. Sketch the graph of $g(x) = (x - 2)^2 + 1$ and identify all the relative extrema and absolute extrema of the function on each of the following intervals.
- (a) $(-\infty, \infty)$
 - (b) $[0, 3]$
 - (c) $[-1, 5]$
 - (d) $[-1, 1]$
 - (e) $[1, 3]$
 - (f) $(2, 4)$
7. Sketch the graph of $h(x) = e^{3-x}$ and identify all the relative extrema and absolute extrema of the function on each of the following intervals.
- (a) $(-\infty, \infty)$
 - (b) $[-1, 3]$
 - (c) $[-6, -1]$
 - (d) $(1, 4]$
8. Sketch the graph of $h(x) = \cos(x) + 2$ and identify all the relative extrema and absolute extrema of the function on each of the following intervals. Do, all work for this problem in radians.
- (a) $(-\infty, \infty)$
 - (b) $\left[-\frac{\pi}{3}, \frac{\pi}{4}\right]$
 - (c) $\left[-\frac{\pi}{2}, 2\pi\right]$
 - (d) $\left[\frac{1}{2}, 1\right]$
9. Sketch the graph of a function on the interval $[3, 9]$ that has an absolute maximum at $x = 5$ and an absolute minimum at $x = 4$.
10. Sketch the graph of a function on the interval $[0, 10]$ that has an absolute minimum at $x = 5$ and an absolute maximums at $x = 0$ and $x = 10$.

11. Sketch the graph of a function on the interval $(-\infty, \infty)$ that has a relative minimum at $x = -7$, a relative maximum at $x = 2$ and no absolute extrema.
12. Sketch the graph of a function that meets the following conditions :
 - (a) Has at least one absolute maximum.
 - (b) Has one relative minimum.
 - (c) Has no absolute minimum.
13. Sketch the graph of a function that meets the following conditions :
 - (a) Graphed on the interval $[2, 9]$.
 - (b) Has a discontinuity at some point interior to the interval.
 - (c) Has an absolute maximum at the discontinuity in part (b).
 - (d) Has an absolute minimum at the discontinuity in part (b).
14. Sketch the graph of a function that meets the following conditions :
 - (a) Graphed on the interval $[-4, 10]$.
 - (b) Has no relative extrema.
 - (c) Has an absolute maximum at one end point.
 - (d) Has an absolute minimum at the other end point.
15. Sketch the graph of a function that meets the following conditions :
 - (a) Has a discontinuity at some point.
 - (b) Has an absolute maximum and an absolute minimum.
 - (c) Neither absolute extrema occurs at the discontinuity.

4.4 Finding Absolute Extrema

For each of the following problems determine the absolute extrema of the given function on the specified interval.

1. $f(z) = 2z^4 - 16z^3 + 20z^2 - 7$ on $[-2, 6]$

2. $f(z) = 2z^4 - 16z^3 + 20z^2 - 7$ on $[-2, 4]$

3. $f(z) = 2z^4 - 16z^3 + 20z^2 - 7$ on $[0, 2]$

4. $Q(w) = 20 + 280w^3 + 75w^4 - 12w^5$ on $[-3, 2]$

5. $Q(w) = 20 + 280w^3 + 75w^4 - 12w^5$ on $[-1, 8]$

6. $g(z) = 8 - 12z^5 - 25z^6 + \frac{90}{7}z^7$ on $[-1, 1]$

7. $g(t) = 3t^4 - 20t^3 - 132t^2 + 672t - 4$ on $[-5, 8]$

Note : Depending upon your factoring skills this may require some computational aids.

8. $g(t) = 3t^4 - 20t^3 - 132t^2 + 672t - 4$ on $[-2, 8]$

Note : Depending upon your factoring skills this may require some computational aids.

9. $V(x) = 14x^3 + 11x^2 - 4x + 3$ on $[-1, 1]$

10. $a(t) = 4 - 2t^2 - 6t^3 - 3t^4$ on $[-2, 1]$

11. $h(x) = 8 + 3x + 7x^2 - x^3$ on $[-1, 5]$

12. $f(x) = 3x^4 - 20x^3 + 6x^2 + 120x + 5$ on $[-1, 5]$

Note : This problem will require some computational aids.

13. $h(v) = v^5 + v^4 + 10v^3 - 15$ on $[-3, 2]$

14. $g(z) = (z - 3)^5(2z + 1)^4$ on $[-1, 3]$

15. $R(q) = (q + 2)^4(q^2 - 8)^2$ on $[-4, 1]$

16. $h(t) = \frac{3 - 4t}{t^2 + 1}$ on $[-2, 4]$

17. $g(x) = \frac{6 + 9x + x^2}{1 + x + x^2}$ on $[-6, 0]$

18. $f(t) = (t^3 - 25t)^{\frac{2}{3}}$ on $[2, 6]$

19. $F(t) = 2 + t^{\frac{2}{5}}(1 + t + t^2)$ on $[-2, 1]$

20. $Q(w) = (6 - w^2) \sqrt[3]{w^2 - 4}$ on $\left[-5, \frac{1}{2}\right]$
21. $g(x) = 3 \cos(2x) - 5x$ on $[0, 6]$
22. $s(w) = 3w - 10 \sin\left(\frac{w}{3}\right)$ on $[10, 38]$
23. $f(x) = 7 \cos(x) + 2x$ on $[-5, 4]$
24. $h(x) = x \cos(x) - \sin(x)$ on $[-15, -5]$
25. $g(z) = z^2 e^{1-z}$ on $\left[-\frac{1}{2}, \frac{5}{2}\right]$
26. $P(t) = (6t + 1) e^{8t-t^2}$ on $[-1, 3]$
27. $f(x) = e^{5+9x} + e^{1-3x} + 6$ on $[-1, 0]$
28. $h(y) = e^{6y^3-8y^2}$ on $\left[-\frac{1}{2}, 1\right]$
29. $Z(t) = \ln(t^2 + t + 3)$ on $[-2, 2]$
30. $f(x) = x - 4 \ln(x^2 + x + 2)$ on $[-1, 9]$
31. $h(t) = \ln(t^2 - t + 1) + \ln(4 - t)$ on $[1, 3]$

4.5 The Shape of a Graph, Part I

For problems 1 - 4 the graph of a function is given. Determine the intervals on which the function increases and decreases.

1.

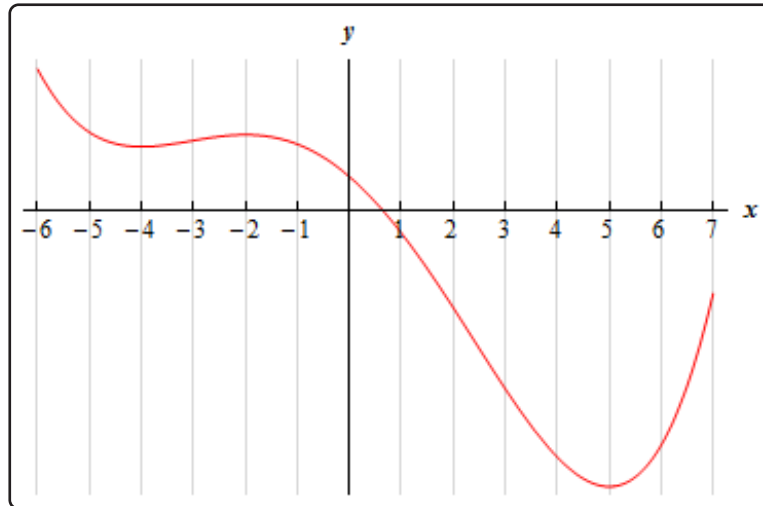

2.

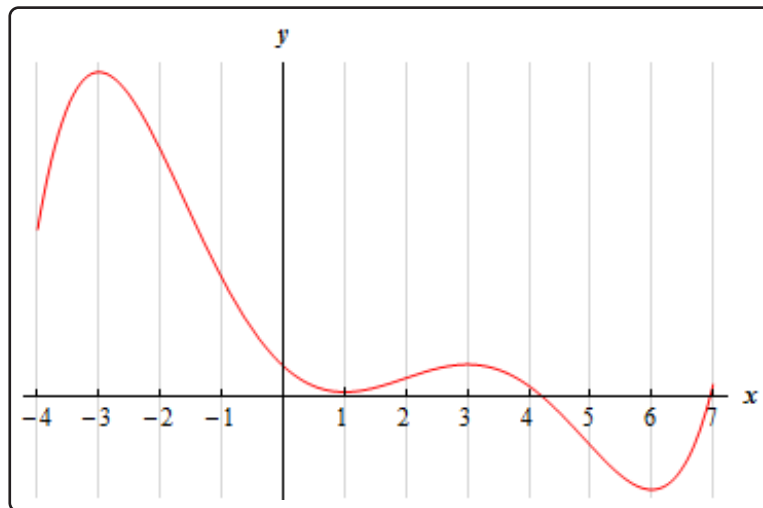

3.

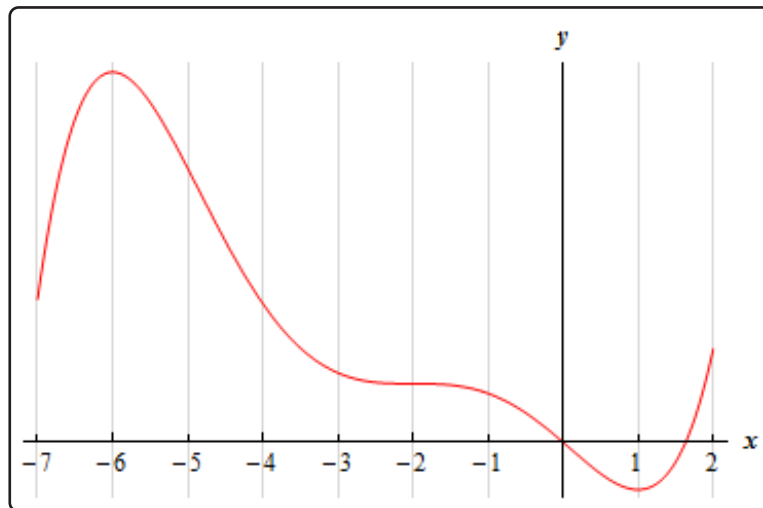

4.

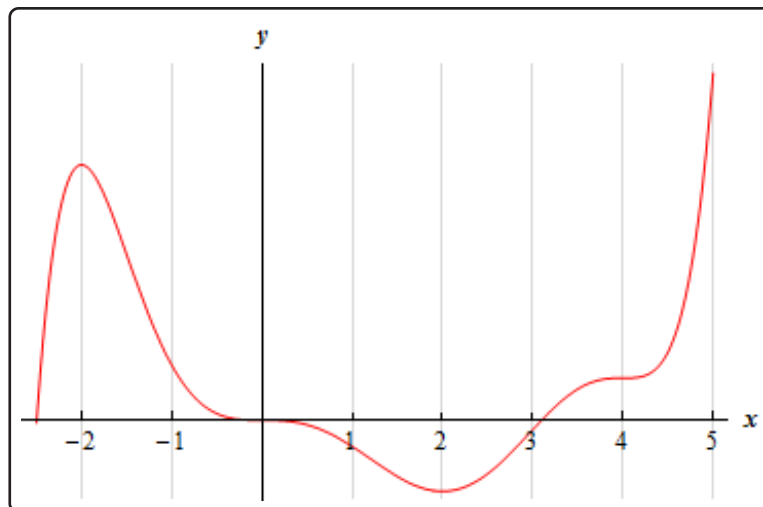

For problems 5 - 7 the graph of the **derivative** of a function is given. From this graph determine the intervals in which the **function** increases and decreases.

5.

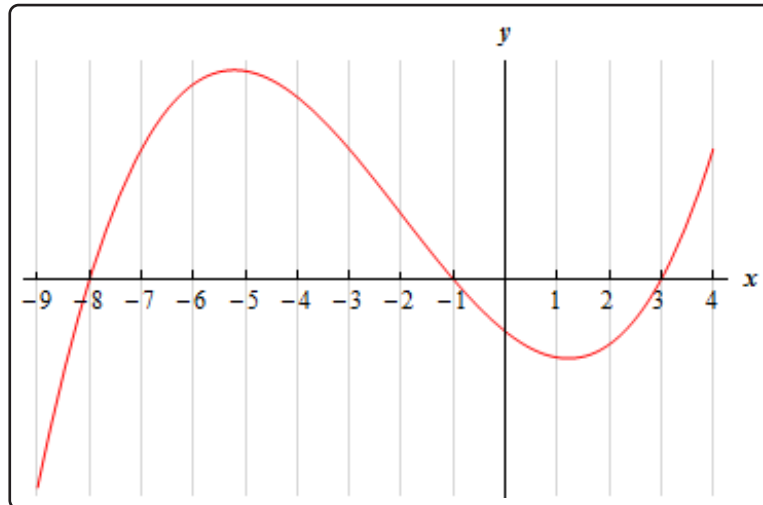

6.

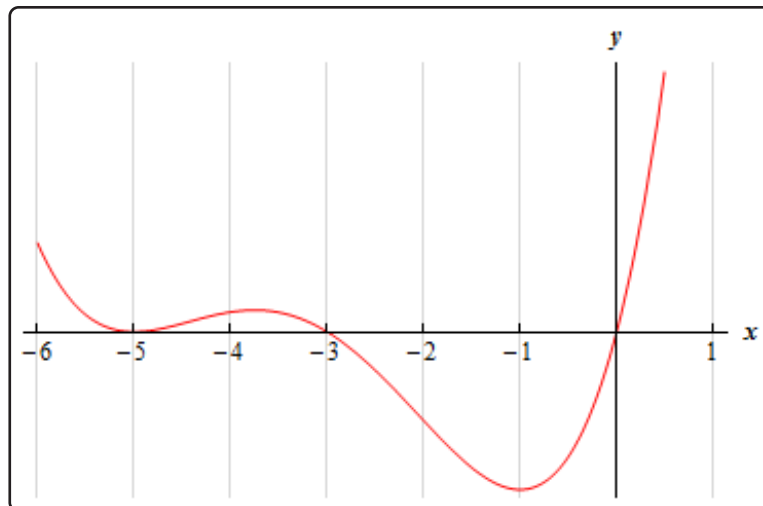

7.

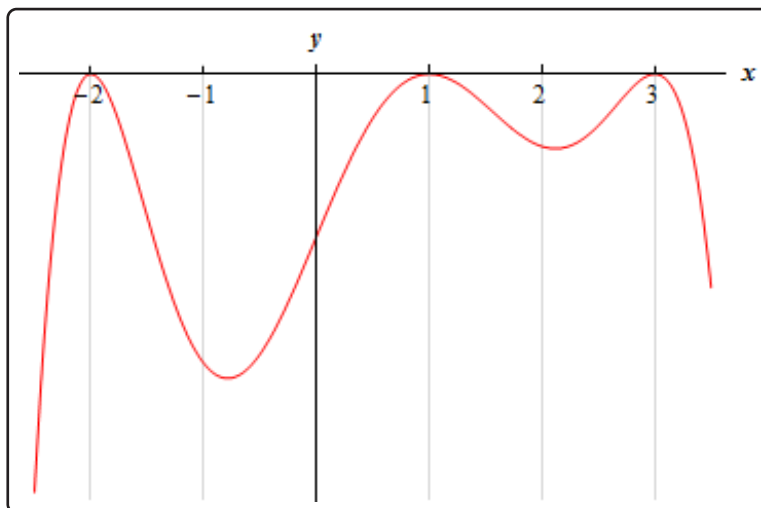

For problems 8 - 10 The known information about the derivative of a function is given. From this information answer each of the following questions.

- (a) Identify the critical points of the function.
 (b) Determine the intervals on which the function increases and decreases.
 (c) Classify the critical points as relative maximums, relative minimums or neither.

8.

$$f'(1) = 0 \quad f'(3) = 0 \quad f'(8) = 0$$

$$f'(x) < 0 \text{ on } (-\infty, 1), (3, 8) \quad f'(x) > 0 \text{ on } (1, 3), (8, \infty)$$

9.

$$g'(-2) = 0 \quad g'(0) = 0 \quad g'(3) = 0 \quad g'(6) = 0$$

$$g'(x) < 0 \text{ on } (0, 3), (6, \infty) \quad g'(x) > 0 \text{ on } (-\infty, -2), (-2, 0), (3, 6)$$

10.

$$h'(-1) = 0 \quad h'(2) = 0 \quad h'(5) = 0$$

$$h'(x) < 0 \text{ on } (-\infty, -1), (-1, 2) \quad h'(x) > 0 \text{ on } (2, 5), (5, \infty)$$

For problems 11 - 28 answer each of the following.

- (a) Identify the critical points of the function.
 (b) Determine the intervals on which the function increases and decreases.
 (c) Classify the critical points as relative maximums, relative minimums or neither.

11. $f(t) = t^3 - 15t^2 + 63t + 3$
12. $g(x) = 20 + 8x^2 + 4x^3 - x^4$
13. $Q(w) = 8w^3 - 18w^2 - 24w - 10$
14. $f(x) = x^5 + \frac{5}{4}x^4 - 20x^3 - 7$
15. $P(x) = 5 - 4x - 9x^2 - 3x^3$
16. $R(z) = z^5 + z^4 - 6z^3 + 5$
17. $h(z) = 1 - 12z^2 - 9z^3 - 2z^4$
18. $Q(t) = 7 - t + \sin(4t)$ on $\left[-\frac{3}{2}, \frac{3}{2}\right]$
19. $f(z) = 6z - 20 \cos\left(\frac{z}{2}\right)$ on $[0, 22]$
20. $g(x) = 24 \cos\left(\frac{x}{3}\right) + 8x + 2$ on $[-30, 25]$
21. $h(w) = 9w - 5 \sin(2w)$ on $[-5, 0]$
22. $h(x) = \sqrt[5]{x}(x + 7)$
23. $W(z) = (10 - w^2)(w + 2)^{\frac{2}{3}}$
24. $f(t) = (t^2 - 8) \sqrt[3]{t^2 - 4}$
25. $f(x) = e^{\frac{1}{3}x^3 - x^2 - 3x}$
26. $h(z) = (z^2 - 8) e^{3-z}$
27. $A(t) = \ln(t^2 + 5t + 8)$
28. $g(x) = x - 3 + \ln(1 + x + x^2)$
29. Answer each of the following questions.
 - (a) What is the minimum degree of a polynomial that has exactly one relative extrema?
 - (b) What is the minimum degree of a polynomial that has exactly two relative extrema?
 - (c) What is the minimum degree of a polynomial that has exactly three relative extrema?
 - (d) What is the minimum degree of a polynomial that has exactly n relative extrema?

30. For some function, $f(x)$, it is known that there is a relative minimum at $x = -4$. Answer each of the following questions about this function.

(a) What is the simplest form that the derivative of this function?

Note : There really are many possible forms of the derivative so to make the rest of this problem as simple as possible you will want to use the simplest form of the derivative.

(b) Using your answer from (a) determine the most general form of the function.

(c) Given that $f(-4) = 6$ find a function that will have a relative minimum at $x = -4$.

Note : There are many possible answers here so just give one of them.

31. For some function, $f(x)$, it is known that there is a relative maximum at $x = -1$. Answer each of the following questions about this function.

(a) What is the simplest form that the derivative of this function?

Note : There really are many possible forms of the derivative so to make the rest of this problem as simple as possible you will want to use the simplest form of the derivative.

(b) Using your answer from (a) determine the most general form of the function.

(c) Given that $f(-1) = 3$ find a function that will have a relative maximum at $x = -1$.

Note : There are many possible answers here so just give one of them.

32. For some function, $f(x)$, it is known that there is a critical point at $x = 3$ that is neither a relative minimum or a relative maximum. Answer each of the following questions about this function.

(a) What is the simplest form that the derivative of this function?

Note : There really are many possible forms of the derivative so to make the rest of this problem as simple as possible you will want to use the simplest form of the derivative.

(b) Using your answer from (a) determine the most general form of the function.

(c) Given that $f(3) = 2$ find a function that will have a critical point at $x = 3$ that is neither a relative minimum or a relative maximum.

Note : There are many possible answers here so just give one of them.

33. For some function, $f(x)$, it is known that there is a relative maximum at $x = 1$ and a relative minimum at $x = 4$. Answer each of the following questions about this function.

(a) What is the simplest form that the derivative of this function?

Note : There really are many possible forms of the derivative so to make the rest of this problem as simple as possible you will want to use the simplest form of the derivative.

(b) Using your answer from (a) determine the most general form form of the function.

(c) Given that $f(1) = 6$ and $f(4) = -2$ find a function that will have a relative maximum at $x = 1$ and a relative minimum at $x = 4$.

Note : There are many possible answers here so just give one of them.

34. Given that $f(x)$ and $g(x)$ are increasing functions will $h(x) = f(x) - g(x)$ always be an increasing function? If so, prove that $h(x)$ will be an increasing function. If not, find increasing functions, $f(x)$ and $g(x)$, so that $h(x)$ will be a decreasing function and find a different set of increasing functions so that $h(x)$ will be an increasing function.

35. Given that $f(x)$ is an increasing function. There are several possible conditions that we can impose on $g(x)$ so that $h(x) = f(x) - g(x)$ will be an increasing function. Determine as many of these possible conditions as you can.

36. For a function $f(x)$ determine a set of conditions on $f(x)$, different from those given in #15 in the practice problems, for which $h(x) = [f(x)]^2$ will be an increasing function.

37. For a function $f(x)$ determine a single condition on $f(x)$ for which $h(x) = [f(x)]^3$ will be an increasing function.

38. Given that $f(x)$ and $g(x)$ are positive functions. Determine a set of conditions on them for which $h(x) = f(x)g(x)$ will be an increasing function. Note that there are several possible sets of conditions here but try to determine the "simplest" set of conditions.

39. Repeat #38 for $h(x) = \frac{f(x)}{g(x)}$.

40. Given that $f(x)$ and $g(x)$ are increasing functions prove that $h(x) = f(g(x))$ will also be an increasing function.

4.6 The Shape of a Graph, Part II

For problems 1 & 2 the graph of a function is given. Determine the intervals on which the function is concave up and concave down.

1.

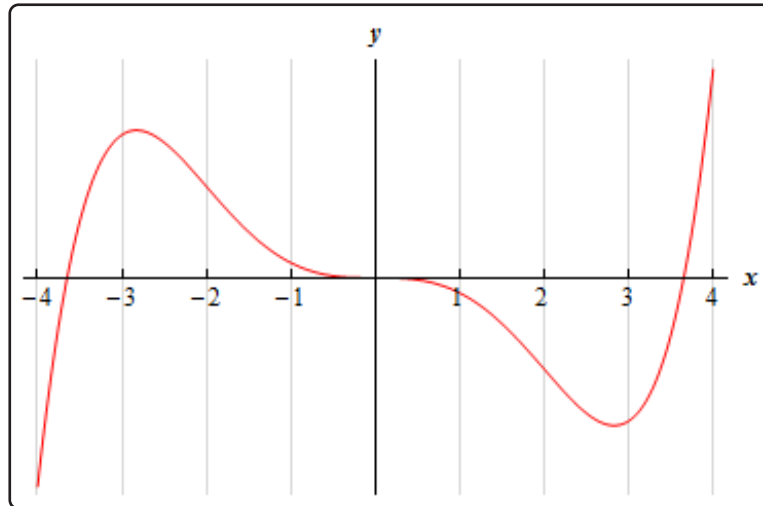

2.

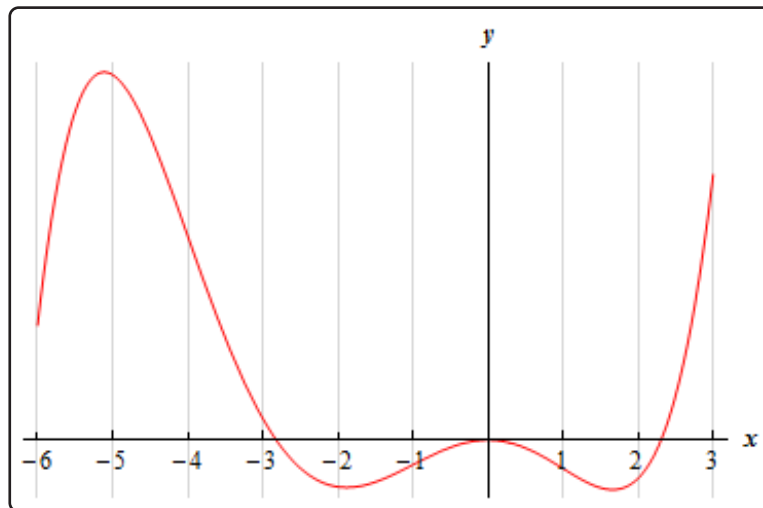

For problems 3 - 5 the graph of the 2^{nd} **derivative** of a function is given. From this graph determine the intervals in which the **function** is concave up and concave down.

3.

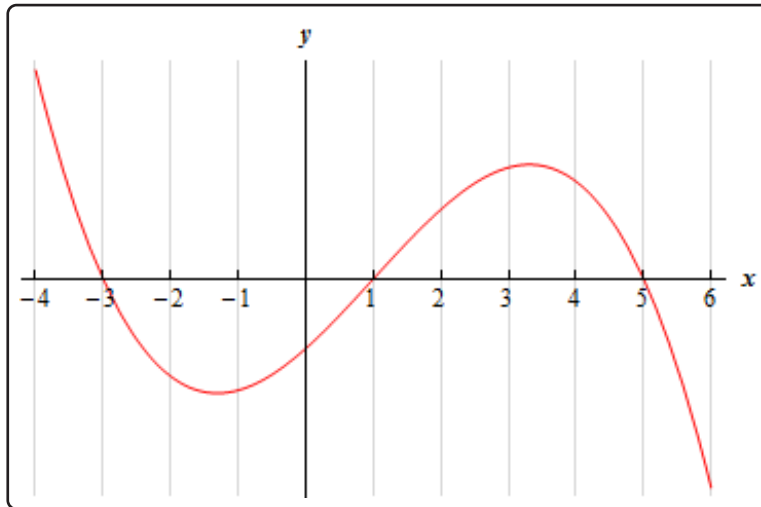

4.

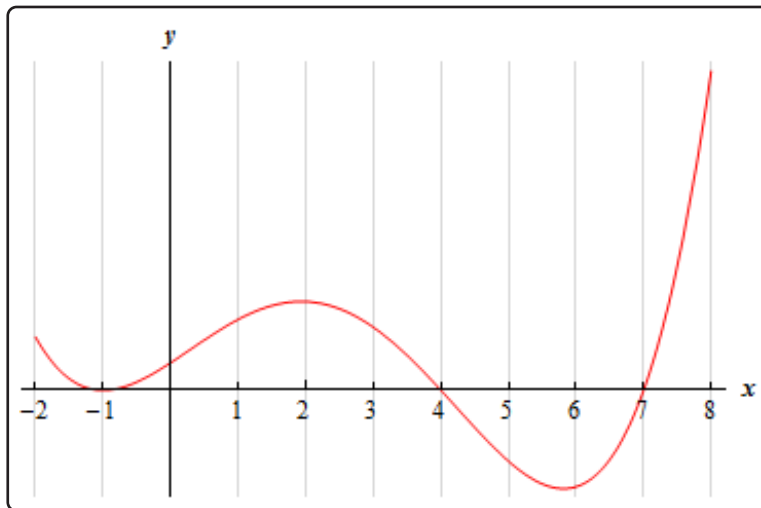

5.

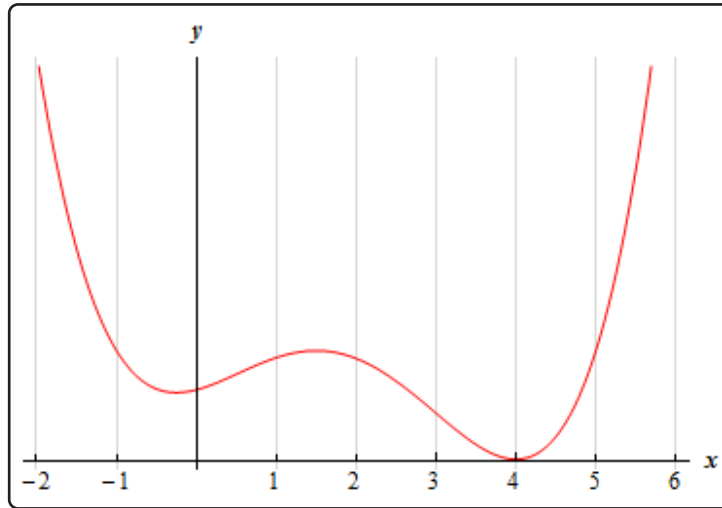

For problems 6 - 18 answer each of the following.

(a) Determine the intervals on which the function is concave up and concave down.

(b) Determine the inflection points of the function.

6. $f(x) = x^3 + 9x^2 + 24x - 6$

7. $Q(t) = t^4 - 2t^3 - 120t^2 - 84t + 35$

8. $h(z) = 3z^5 - 20z^4 + 40z^3$

9. $g(w) = 5w^4 - 2w^3 - 18w^2 + 108w - 12$

10. $g(x) = 10 + 360x + 20x^4 + 3x^5 - x^6$

11. $A(x) = 9x - 3x^2 - 160 \sin\left(\frac{x}{4}\right)$ on $[-20, 11]$

12. $f(x) = 3 \cos(2x) - x^2 - 14$ on $[0, 6]$

13. $h(t) = 1 + 2t^2 - \sin(2t)$ on $[-2, 4]$

14. $R(v) = v(v - 8)^{\frac{1}{3}}$

15. $g(x) = (x - 1)(x + 3)^{\frac{2}{5}}$

16. $f(x) = e^{4x} - e^{-x}$

17. $h(w) = w^2 e^{-w}$

18. $A(w) = w^2 - \ln(w^2 + 1)$

For problems 19 - 33 answer each of the following.

- (a) Identify the critical points of the function.
- (b) Determine the intervals on which the function increases and decreases.
- (c) Classify the critical points as relative maximums, relative minimums or neither.
- (d) Determine the intervals on which the function is concave up and concave down.
- (e) Determine the inflection points of the function.
- (f) Use the information from steps (a) - (e) to sketch the graph of the function.

19. $f(x) = 10 - 30x^2 + 2x^3$

20. $G(t) = 14 + 4t^3 - t^4$

21. $h(w) = w^4 + 4w^3 - 18w^2 - 9$

22. $g(z) = 10z^3 + 10z^4 + 3z^5$

23. $f(z) = z^6 - 9z^5 + 20z^4 + 10$

24. $Q(t) = 3t - 5 \sin(2t)$ on $[-1, 4]$

25. $g(x) = \frac{1}{2}x + \cos\left(\frac{1}{3}x\right)$ on $[-25, 0]$

26. $h(x) = x(x - 4)^{\frac{1}{3}}$

27. $f(t) = t \sqrt{t^2 + 1}$

28. $A(z) = z^{\frac{4}{5}}(z - 27)$

29. $g(w) = e^{4w} - e^{6w}$

30. $P(t) = 3te^{1 - \frac{1}{4}t^2}$

31. $g(x) = (x + 1)^3 e^{-x}$

32. $h(z) = \ln(z^2 + z + 1)$

33. $f(w) = 2w - 8 \ln(w^2 + 4)$

34. Answer each of the following questions.
- (a) What is the minimum degree of a polynomial that has exactly two inflection points.
 - (b) What is the minimum degree of a polynomial that has exactly three inflection points.
 - (c) What is the minimum degree of a polynomial that has exactly n inflection points.
35. For some function, $f(x)$, it is known that there is an inflection point at $x = 3$. Answer each of the following questions about this function.
- (a) What is the simplest form that the 2^{nd} derivative of this function?
 - (b) Using your answer from (a) determine the most general form of the function.
 - (c) Given that $f(0) = -6$ and $f(3) = 1$ find a function that will have an inflection point at $x = 3$.

For problems 36 - 39 $f(x)$ is a polynomial. Given the 2^{nd} derivative of the function, classify, if possible, each of the given critical points as relative minimums or relative maximum. If it is not possible to classify the critical point(s) clearly explain why they cannot be classified.

36. $f''(x) = 3x^2 - 4x - 15$. The critical points are : $x = -3$, $x = 0$ and $x = 5$.
37. $f''(x) = 4x^3 - 21x^2 - 24x + 68$. The critical points are : $x = -2$, $x = 4$ and $x = 7$.
38. $f''(x) = 23 + 18x - 9x^2 - 4x^3$. The critical points are : $x = -4$, $x = -1$ and $x = 3$.
39. $f''(x) = 216 - 410x + 249x^2 - 60x^3 + 5x^4$. The critical points are : $x = 1$, $x = 4$ and $x = 5$.
40. Use $f(x) = (x + 1)^3(x - 1)^4$ for this problem.
- (a) Determine the critical points for the function.
 - (b) Use the 2^{nd} derivative test to classify the critical points as relative minimums or relative maximums. If it is not possible to classify the critical point(s) clearly explain why they cannot be classified.
 - (c) Use the 1^{st} derivative test to classify the critical points as relative minimums, relative maximums or neither.
41. Given that $f(x)$ and $g(x)$ are concave down functions. If we define $h(x) = f(x) + g(x)$ show that $h(x)$ is a concave down function.
42. Given that $f(x)$ is a concave up function. Determine a condition on $g(x)$ for which $h(x) = f(x) + g(x)$ will be a concave up function.
43. For a function $f(x)$ determine conditions on $f(x)$ for which $h(x) = [f(x)]^2$ will be a concave up function. Note that there are several sets of conditions that can be used here. How many of them can you find?

4.7 The Mean Value Theorem

For problems 1 - 4 determine all the number(s) c which satisfy the conclusion of Rolle's Theorem for the given function and interval.

1. $f(x) = x^3 - 4x^2 + 3$ on $[0, 4]$
2. $Q(z) = 15 + 2z - z^2$ on $[-2, 4]$
3. $h(t) = 1 - e^{t^2-9}$ on $[-3, 3]$
4. $g(w) = 1 + \cos[\pi w]$ on $[5, 9]$

For problems 5 - 8 determine all the number(s) c which satisfy the conclusion of the Mean Value Theorem for the given function and interval.

5. $f(x) = x^3 - x^2 + x + 8$ on $[-3, 4]$
6. $g(t) = 2t^3 + t^2 + 7t - 1$ on $[1, 6]$
7. $P(t) = e^{2t} - 6t - 3$ on $[-1, 0]$
8. $h(x) = 9x - 8 \sin\left(\frac{x}{2}\right)$ on $[-3, -1]$
9. Suppose we know that $f(x)$ is continuous and differentiable on the interval $[-2, 5]$, that $f(5) = 14$ and that $f'(x) \leq 10$. What is the smallest possible value for $f(-2)$?
10. Suppose we know that $f(x)$ is continuous and differentiable on the interval $[-6, -1]$, that $f(-6) = -23$ and that $f'(x) \geq -4$. What is the smallest possible value for $f(-1)$?
11. Suppose we know that $f(x)$ is continuous and differentiable on the interval $[-3, 4]$, that $f(-3) = 7$ and that $f'(x) \leq -17$. What is the largest possible value for $f(4)$?
12. Suppose we know that $f(x)$ is continuous and differentiable on the interval $[1, 9]$, that $f(9) = 0$ and that $f'(x) \geq 8$. What is the largest possible value for $f(1)$?
13. Show that $f(x) = x^7 + 2x^5 + 3x^3 + 14x + 1$ has exactly one real root.
14. Show that $f(x) = 6x^3 - 2x^2 + 4x - 3$ has exactly one real root.
15. Show that $f(x) = 20x - e^{-4x}$ has exactly one real root.

4.8 Optimization

1. Find two positive numbers whose sum of six times one of them and the second is 250 and whose product is a maximum.
2. Find two positive numbers whose sum of twice the first and seven times the second is 600 and whose product is a maximum.
3. Let x and y be two positive numbers whose sum is 175 and $(x + 3)(y + 4)$ is a maximum. Determine x and y .
4. Find two positive numbers such that the sum of the one and the square of the other is 200 and whose product is a maximum.
5. Find two positive numbers whose product is 400 and such that the sum of twice the first and three times the second is a minimum.
6. Find two positive numbers whose product is 250 and such that the sum of the first and four times the second is a minimum.
7. Let x and y be two positive numbers such that $y(x + 2) = 100$ and whose sum is a minimum. Determine x and y .
8. Find a positive number such that the sum of the number and its reciprocal is a minimum.
9. We are going to fence in a rectangular field and have 200 feet of material to construct the fence. Determine the dimensions of the field that will enclose the maximum area.
10. We are going to fence in a rectangular field. Starting at the bottom of the field and moving around the field in a counter clockwise manner the cost of material for each side is \$6/ft, \$9/ft, \$12/ft and \$14/ft respectively. If we have \$1000 to buy fencing material determine the dimensions of the field that will maximize the enclosed area.
11. We are going to fence in a rectangular field that encloses 75 ft^2 . Determine the dimensions of the field that will require the least amount of fencing material to be used.
12. We are going to fence in a rectangular field that encloses 200 m^2 . If the cost of the material for of one pair of parallel sides is \$3/m and cost of the material for the other pair of parallel sides is \$8/m determine the dimensions of the field that will minimize the cost to build the fence around the field.
13. Show that a rectangle with a fixed area and minimum perimeter is a square.
14. Show that a rectangle with a fixed perimeter and a maximum area is a square.
15. We have 350 m^2 of material to build a box whose base width is four times the base length. Determine the dimensions of the box that will maximize the enclosed volume.

16. We have \$1000 to buy the materials to build a box whose base length is seven times the base width and has no top. If the material for the sides cost $\$10/\text{cm}^2$ and the material for the bottom cost $\$15/\text{cm}^2$ determine the dimensions of the box that will maximize the enclosed volume.
17. We want to build a box whose base length is twice the base width and the box will enclose 80 ft^3 . The cost of the material of the sides is $\$0.5/\text{ft}^2$ and the cost of the top/bottom is $\$3/\text{ft}^2$. Determine the dimensions of the box that will minimize the cost.
18. We want to build a box whose base is a square, has no top and will enclose 100 m^3 . Determine the dimensions of the box that will minimize the amount of material needed to construct the box.
19. We want to construct a cylindrical can with a bottom but no top that will have a volume of 65 in^3 . Determine the dimensions of the can that will minimize the amount of material needed to construct the can.
20. We want to construct a cylindrical can whose volume is 105 mm^3 . The material for the wall of the can costs $\$3/\text{mm}^2$, the material for the bottom of the can costs $\$7/\text{mm}^2$ and the material for the top of the can costs $\$2/\text{mm}^2$. Determine the dimensions of the can that will minimize the cost of the materials needed to construct the can.
21. We have a piece of cardboard that is 30 cm by 16 cm and we are going to cut out the corners and fold up the sides to form a box. Determine the height of the box that will give a maximum volume.

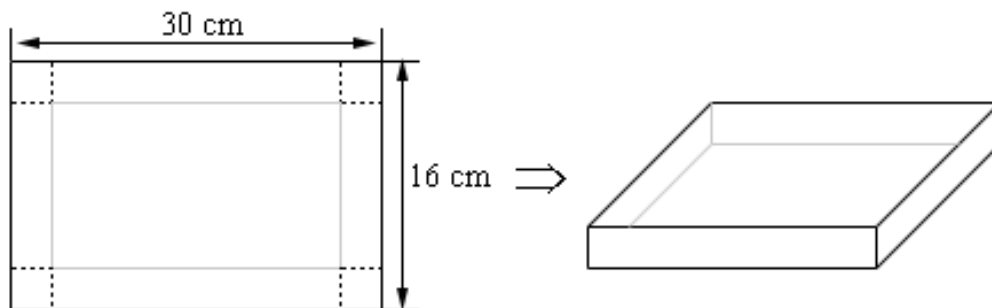

22. We have a piece of cardboard that is 5 in by 20 in and we are going to cut out the corners and fold up the sides to form a box. Determine the height of the box that will give a maximum volume.

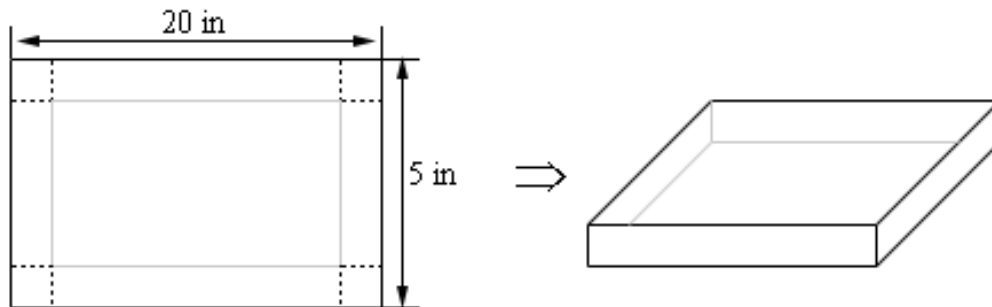

23. A printer needs to make a poster that will have a total of 500 cm^2 that will have 3 cm margins on the sides and 2 cm margins on the top and bottom. What dimensions of the poster will give the largest printed area?

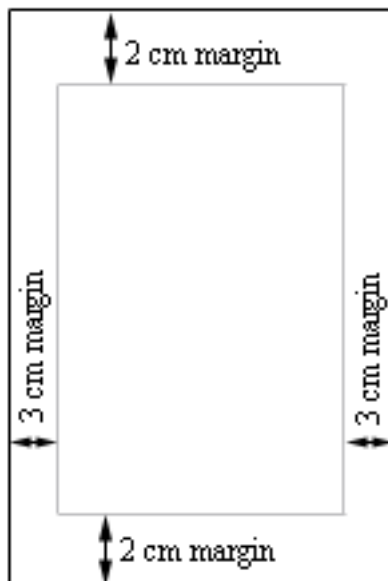

24. A printer needs to make a poster that will have a total of 125 in^2 that will have $\frac{1}{2}$ inch margin on the bottom, 1 inch margin on the right, 2 inch margin on the left and 4 inch margin on the top. What dimensions of the poster will give the largest printed area?

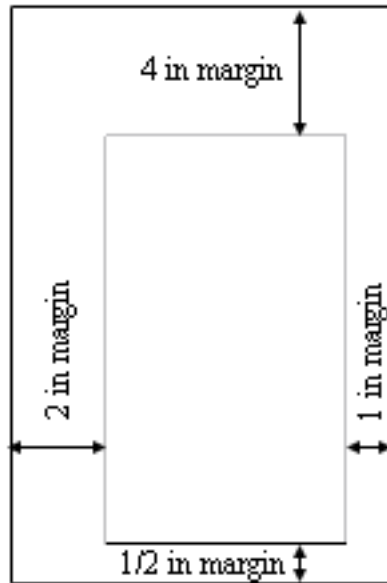

4.9 More Optimization

1. We want to construct a window whose bottom is a rectangle and the top of the window is an equilateral triangle. If we have 75 inches of framing material what are the dimensions of the window that will let in the most light?
2. We want to construct a window whose middle is a rectangle and the top and bottom of the window are equilateral triangles. If we have 4 feet of framing material what are the dimensions of the window that will let in the most light?
3. We want to construct a window whose middle is a rectangle, the top of the window is a semicircle and the bottom of the window is an equilateral triangle. If we have 1500 cm of framing material what are the dimensions of the window that will let in the most light?
4. Determine the area of the largest rectangle that can be inscribed in a circle of radius 5.

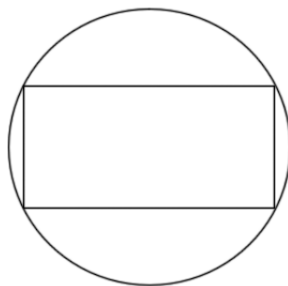

5. Determine the area of the largest rectangle whose base is on the x -axis and the top two corners lie on semicircle of radius 16.

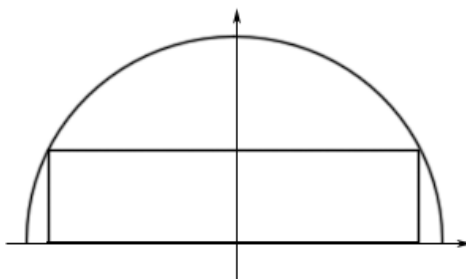

6. Determine the area of the largest rectangle whose base is on the x -axis and the top two corners lie $y = 4 - x^2$.

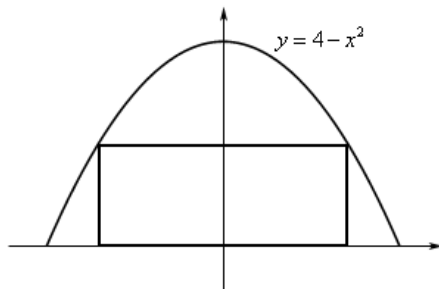

7. Find the point(s) on $\frac{x^2}{4} + \frac{y^2}{36} = 1$ that are closest to $(0, 1)$.
8. Find the point(s) on $x = y^2 - 8$ that are closest to $(5, 0)$.
9. Find the point(s) on $y = 2 - x^2$ that are closest to $(0, -3)$.
10. A 6 ft piece of wire is cut into two pieces. One piece is bent into an equilateral triangle and the other will be bent into a rectangle with one side twice the length of the other side. Determine where, if anywhere, the wire should be cut to minimize the area enclosed by the two figures.
11. A 250 cm piece of wire is cut into two pieces. One piece is bent into an equilateral triangle and the other will be bent into circle. Determine where, if anywhere, the wire should be cut to maximize the area enclosed by the two figures.
12. A 250 cm piece of wire is cut into two pieces. One piece is bent into an equilateral triangle and the other will be bent into circle. Determine where, if anywhere, the wire should be cut to minimize the area enclosed by the two figures.
13. A 4 m piece of wire is cut into two pieces. One piece is bent into a circle and the other will be bent into a rectangle with one side three times the length of the other side. Determine where, if anywhere, the wire should be cut to maximize the area enclosed by the two figures.
14. A line through the point $(-4, 1)$ forms a right triangle with the x -axis and y -axis in the 2^{nd} quadrant. Determine the equation of the line that will minimize the area of this triangle.

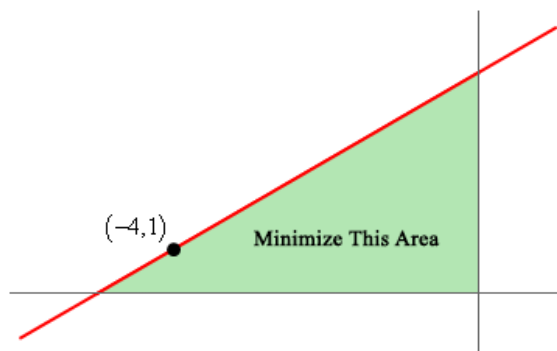

15. A line through the point $(3, 3)$ forms a right triangle with the x -axis and y -axis in the 1st quadrant. Determine the equation of the line that will minimize the area of this triangle.

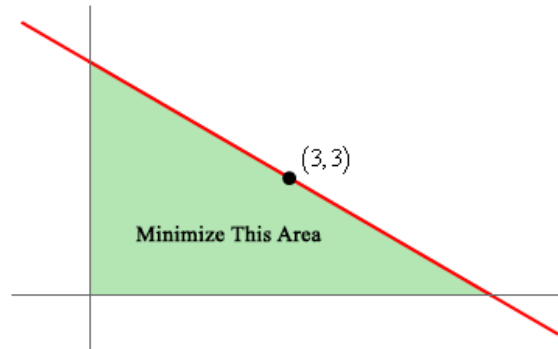

16. A piece of pipe is being carried down a hallway that is 14 feet wide. At the end of the hallway there is a right-angled turn and the hallway narrows down to 6 feet wide. What is the longest pipe (always keeping it horizontal) that can be carried around the turn in the hallway?

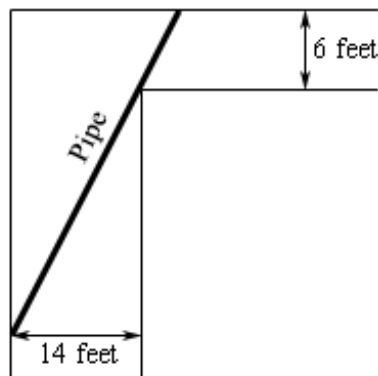

17. A piece of pipe is being carried down a hallway that is 9 feet wide. At the end of the hallway there is a right-angled turn and the hallway widens up to 21 feet wide. What is the longest pipe (always keeping it horizontal) that can be carried around the turn in the hallway?

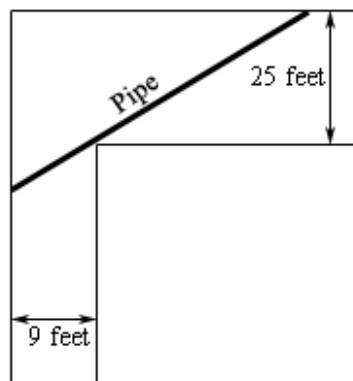

18. Two poles, one 15 meters tall and one 10 meters tall, are 40 meters apart. A length of wire is attached to the top of each pole and it is staked to the ground somewhere between the two poles. Where should the wire be staked so that the minimum amount of wire is used?

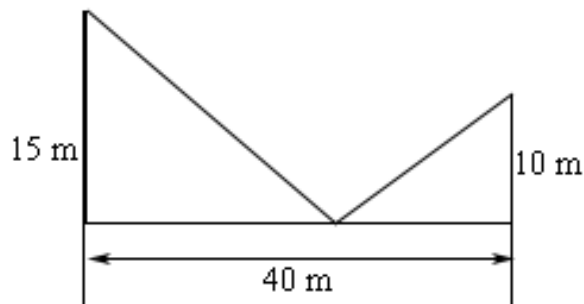

19. Two poles, one 2 feet tall and one 5 feet tall, are 3 feet apart. A length of wire is attached to the top of each pole and it is staked to the ground somewhere between the two poles. Where should the wire be staked so that the minimum amount of wire is used?

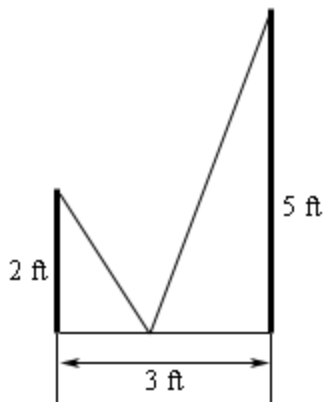

20. Two poles, one 15 meters tall and one 10 meters tall, are 40 meters apart. A length of wire is attached to the top of each pole and it is staked to the ground somewhere between the two poles. Where should the wire be staked so that the angle formed by the two pieces of wire at the stake is a maximum?

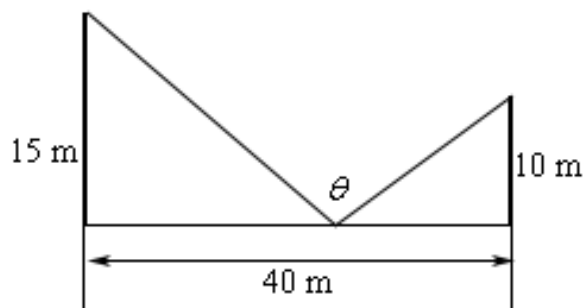

21. Two poles, one 34 inches tall and one 17 inches tall, are 3 feet apart. A length of wire is attached to the top of each pole and it is staked to the ground somewhere between the two poles. Where should the wire be staked so that the angle formed by the two pieces of wire at the stake is a maximum?

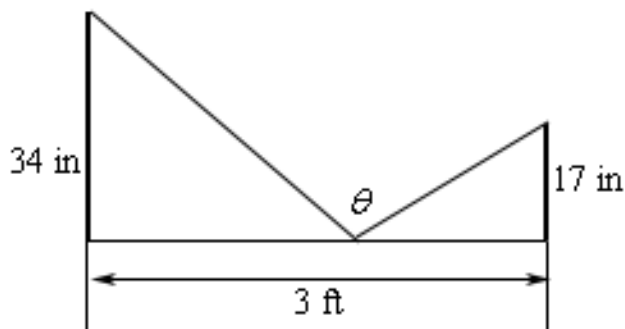

22. A trough for holding water is to be formed as shown in the figure below. Determine the angle θ that will maximize the amount of water that the trough can hold.

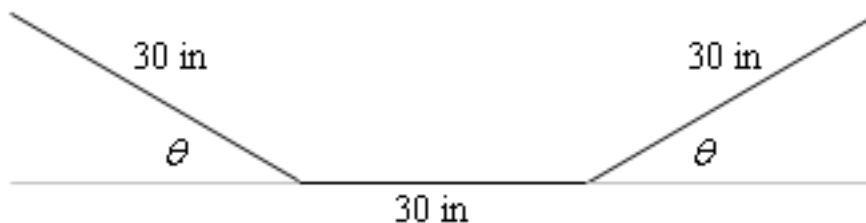

23. A trough for holding water is to be formed as shown in the figure below. Determine the angle θ that will maximize the amount of water that the trough can hold.

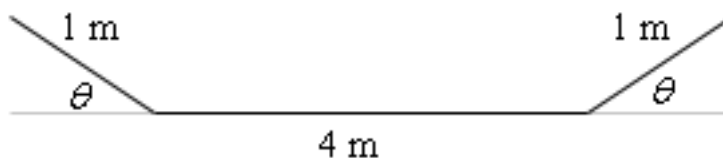

4.10 L'Hospital's Rule and Indeterminate Forms

For problems 1 - 18 use L'Hospital's Rule to evaluate the given limit.

$$1. \lim_{x \rightarrow -4} \frac{x^3 + 6x^2 - 32}{x^3 + 5x^2 + 4x}$$

$$2. \lim_{w \rightarrow -\infty} \frac{e^{-6w}}{4 + e^{-3w}}$$

$$3. \lim_{t \rightarrow 0} \frac{\sin(6t)}{\sin(11t)}$$

$$4. \lim_{x \rightarrow 1} \frac{x^2 + 8x - 9}{x^3 - 2x^2 - 5x + 6}$$

$$5. \lim_{t \rightarrow 2} \frac{t^3 - 7t^2 + 16t - 12}{t^4 - 4t^3 + 4t^2}$$

$$6. \lim_{w \rightarrow -\infty} \frac{w^2 - 4w + 1}{3w^2 + 7w - 4}$$

$$7. \lim_{y \rightarrow \infty} \frac{y^2 - e^{6y}}{4y^2 + e^{7y}}$$

$$8. \lim_{x \rightarrow 0} \frac{2 \cos(4x) - 4x^2 - 2}{\sin(2x) - x^2 - 2x}$$

$$9. \lim_{x \rightarrow -3} \frac{3e^{2x+6} + x^2 - 12}{x^3 + 6x^2 + 9x}$$

$$10. \lim_{z \rightarrow 6} \frac{\sin(\pi z)}{\ln(z - 5)}$$

$$11. \lim_{w \rightarrow \infty} \left[w \ln \left(1 - \frac{2}{3w} \right) \right]$$

$$12. \lim_{t \rightarrow 0^+} [\ln(t) \sin(t)]$$

$$13. \lim_{z \rightarrow -\infty} z^2 e^z$$

$$14. \lim_{x \rightarrow \infty} \left[x \sin \left(\frac{7}{x} \right) \right]$$

$$15. \lim_{z \rightarrow 0^+} [z^2 (\ln z)^2]$$

$$16. \lim_{x \rightarrow 0^+} x^{1/x}$$

$$17. \lim_{t \rightarrow 0^+} [e^t + t]^{1/t}$$

18. $\lim_{x \rightarrow \infty} [e^{-2x} + 3x]^{1/x}$

19. Suppose that we know that $f'(x)$ is a continuous function. Use L'Hospital's Rule to show that,

$$\lim_{h \rightarrow 0} \frac{f(x+h) - f(x-h)}{2h} = f'(x)$$

20. Suppose that we know that $f''(x)$ is a continuous function. Use L'Hospital's Rule to show that,

$$\lim_{h \rightarrow 0} \frac{f(x+h) - 2f(x) + f(x-h)}{h^2} = f''(x)$$

4.11 Linear Approximations

For problems 1 - 4 find a linear approximation to the function at the given point.

1. $f(x) = \cos(2x)$ at $x = \pi$
2. $h(z) = \ln(z^2 + 5)$ at $z = 2$
3. $g(x) = 2 - 9x - 3x^2 - x^3$ at $x = -1$
4. $g(t) = e^{\sin(t)}$ at $t = -4$
5. Find the linear approximation to $h(y) = \sin(y + 1)$ at $y = 0$. Use the linear approximation to approximate the value of $\sin(2)$ and $\sin(15)$. Compare the approximated values to the exact values.
6. Find the linear approximation to $R(t) = \sqrt[5]{t}$ at $t = 32$. Use the linear approximation to approximate the value of $\sqrt[5]{31}$ and $\sqrt[5]{3}$. Compare the approximated values to the exact values.
7. Find the linear approximation to $h(x) = e^{1-x}$ at $x = 1$. Use the linear approximation to approximate the value of e and e^{-4} . Compare the approximated values to the exact values.

For problems 8 - 10 estimate the given value using a linear approximation and without using any kind of computational aid.

8. $\ln(1.1)$
9. $\sqrt{8.9}$
10. $\sec(0.1)$

4.12 Differentials

For problems 1 - 5 compute the differential of the given function.

1. $f(x) = 3x^6 - 8x^3 + x^2 - 9x - 4$
2. $u = t^2 \cos(2t)$
3. $y = e^{\cos(z)}$
4. $g(z) = \sin(3z) - \cos(1 - z)$
5. $R(x) = \sqrt[4]{6x + e^{-x}}$
6. Compute dy and Δy for $y = \sin(x)$ as x changes from 6 radians to 6.05 radians.
7. Compute dy and Δy for $y = \ln(x^2 + 1)$ as x changes from -2 to -2.1.
8. Compute dy and Δy for $y = \frac{1}{x - 2}$ as x changes from 3 to 3.02.
9. Compute dy and Δy for $y = x e^{\frac{1}{4}x}$ as x changes from -10 to -9.99.
10. The sides of a cube are found to be 6 feet in length with a possible error of no more than 1.5 inches. What is the maximum possible error in the surface area of the cube if we use this value of the length of the side to compute the surface area?
11. The radius of a circle is found to be 7 cm in length with a possible error of no more than 0.04 cm. What is the maximum possible error in the area of the circle if we use this value of the radius to compute the area?
12. The radius of a sphere is found to be 22 cm in length with a possible error of no more than 0.07 cm. What is the maximum possible error in the volume of the sphere if we use this value of the radius to compute the volume?
13. The radius of a sphere is found to be $\frac{1}{2}$ foot in length with a possible error of no more than 0.03 inches. What is the maximum possible error in the surface area of the sphere if we use this value of the radius to compute the surface area?

4.13 Newton's Method

For problems 1 - 3 use Newton's Method to determine x_2 for the given function and given value of x_0 .

1. $f(x) = 7x^3 - 8x + 4$, $x_0 = -1$
2. $f(x) = \cos(3x) - \sin(x)$, $x_0 = 0$
3. $f(x) = 7 - e^{2x-3}$, $x_0 = 5$

For problems 4 - 8 use Newton's Method to find the root of the given equation, accurate to six decimal places, that lies in the given interval.

4. $x^5 = 6$ in $[1, 2]$
5. $2x^3 - 9x^2 + 17x + 20 = 0$ in $[-1, 1]$
6. $3 - 12x - 4x^3 - 3x^4 = 0$ in $[-3, -1]$
7. $e^x = 4 \cos(x)$ in $[-1, 1]$
8. $x^2 = e^{2-x^2}$ in $[0, 2]$

For problems 9 - 12 use Newton's Method to find all the roots of the given equation accurate to six decimal places.

9. $2x^3 + 5x^2 - 10x - 4 = 0$
10. $x^4 + 4x^3 - 54x^2 - 92x + 105 = 0$
11. $\frac{3}{2} - e^{-x^2} = \cos(x)$
12. $\ln(x) = 2 \cos(x)$
13. Suppose that we want to find the root to $x^3 - 7x^2 + 8x - 3 = 0$. Is it possible to use $x_0 = 4$ as the initial point? What can you conclude about using Newton's Method to approximate roots from this example?

14. Use the function $f(x) = \cos^2(x) - \sin(x)$ for this problem.
- (a) Plot the function on the interval $[0, 9]$.
 - (b) Use $x_0 = 4$ to find one of the roots of this function to six decimal places. Did you get the root you expected to?
 - (c) Use $x_0 = 5$ to find one of the roots of this function to six decimal places. Did you get the root you expected to?
 - (d) Use $x_0 = 6$ to find one of the roots of this function to six decimal places. Did you get the root you expected to?
 - (e) What can you conclude about choosing values of x_0 to find roots of equations using Newton's Method.
15. Use $x_0 = 0$ to find one of the roots of $2x^5 - 7x^3 + 3x - 1 = 0$ accurate to six decimal places. Did we choose a good value of x_0 for this problem?

4.14 Business Applications

1. A company can produce a maximum of 2500 widgets in a year. If they sell x widgets during the year then their profit, in dollars, is given by,

$$P(x) = 500,000,000 - 1,540,000x + 1450x^2 - \frac{1}{3}x^3$$

How many widgets should they try to sell in order to maximize their profit?

2. A company can produce a maximum of 25 widgets in a day. If they sell x widgets during the day then their profit, in dollars, is given by,

$$P(x) = 3000 - 40x + 11x^2 - \frac{1}{3}x^3$$

How many widgets should they try to sell in order to maximize their profit?

3. A management company is going to build a new apartment complex. They know that if the complex contains x apartments the maintenance costs for the building, landscaping etc. will be,

$$C(x) = 70,000 + \frac{2736}{5}x - \frac{211}{50}x^2 + \frac{1}{150}x^3$$

The land they have purchased can hold a complex of at most 400 apartments. How many apartments should the complex have in order to minimize the maintenance costs?

4. The production costs of producing x widgets is given by,

$$C(x) = 2000 + 4x + \frac{90,000}{x}$$

If the company can produce at most 200 widgets how many should they produce to minimize the production costs?

5. The production costs, in dollars, per day of producing x widgets is given by,

$$C(x) = 400 - 3x + 2x^2 + 0.002x^3$$

What is the marginal cost when $x = 20$ and $x = 75$? What do your answers tell you about the production costs?

6. The production costs, in dollars, per month of producing x widgets is given by,

$$C(x) = 10,000 + 14x - \frac{8,000,000}{x^2}$$

What is the marginal cost when $x = 80$ and $x = 150$? What do your answers tell you about the production costs?

7. The production costs, in dollars, per week of producing x widgets is given by,

$$C(x) = 65,000 + 4x + 0.2x^2 - 0.00002x^3$$

and the demand function for the widgets is given by,

$$p(x) = 5000 - 0.5x$$

What is the marginal cost, marginal revenue and marginal profit when $x = 2000$ and $x = 4800$? What do these numbers tell you about the cost, revenue and profit?

8. The production costs, in dollars, per week of producing x widgets is given by,

$$C(x) = 800 + 0.008x^2 + \frac{56,000}{x}$$

and the demand function for the widgets is given by,

$$p(x) = 350 - 0.05x - 0.001x^2$$

What is the marginal cost, marginal revenue and marginal profit when $x = 175$ and $x = 325$? What do these numbers tell you about the cost, revenue and profit?

5 Integrals

In this chapter we will be looking at the third and final major topic that will be covered in this class, integrals. As with derivatives this chapter will be devoted almost exclusively to finding and computing integrals. Applications will be given in the following chapter. There are really two types of integrals that we'll be looking at in this chapter : Indefinite Integrals and Definite Integrals. The first half of this chapter is devoted to indefinite integrals and the last half is devoted to definite integrals.

As we investigate indefinite integrals we will see that as long as we understand basic differentiation we shouldn't have a lot of problems with basic indefinite integrals. The reason for this is that indefinite integration is basically "undoing" differentiation. In fact, indefinite integrals are sometimes called anti-derivatives to make this idea clear. Having said that however we will be using the phrase indefinite integral instead of anti-derivative as that is the more common phrase used.

We will also spend a fair amount of time learning the substitution rule for integrals. We will see that it is really just "undoing" the chain rule and so, again, if you understand the chain rule it will help when using the substitution rule. In addition, as we'll see as we go through the rest of the calculus course the substitution rule will come up time and again and so it is very important to make sure that we have that down so we don't have issues with it in later topics.

As we move over to investigating definite integrals we will quickly realize just how important it is to be able to do indefinite integrals. As we will see we will not be able to compute definite integrals unless we can first compute indefinite integrals.

We will also take a look at an important interpretation of definite integrals. Namely, a definite integral can be interpreted as the net area between the graph of the function and the x -axis.

The following sections are the assignment problems (no solutions available) for this material.

If you are looking for some practice problems (with solutions available) please check out the [Practice Problems](#). There you will find a set of problems that should give you quite a bit practice.

5.1 Indefinite Integrals

1. Evaluate each of the following indefinite integrals.

(a) $\int 10x^9 - 12x^3 - 5 dx$

(b) $\int 10x^9 - 12x^3 dx - 5$

2. Evaluate each of the following indefinite integrals.

(a) $\int t^7 + 33t^2 + 8t dt$

(b) $\int t^7 dt + 33t^2 + 8t$

3. Evaluate each of the following indefinite integrals.

(a) $\int 6x^5 - 7x^3 + 12x^2 - 10 dx$

(b) $\int 6x^5 - 7x^3 dx + 12x^2 - 10$

(c) $\int 6x^5 dx - 7x^3 + 12x^2 - 10$

4. Evaluate each of the following indefinite integrals.

(a) $\int 21x^6 - 9x^5 - x^3 - x dx$

(b) $\int 21x^6 - 9x^5 - x^3 dx - x$

(c) $\int 21x^6 - 9x^5 dx - x^3 - x$

For problems 5 - 9 evaluate the indefinite integral.

5. $\int 8t^5 - 15t^2 - 1 dt$

6. $\int 120y^9 - 24y^5 - 4y^3 dy$

7. $\int dw$

8. $\int x^9 + 14x^6 - 10x^3 + 13x \, dx$

9. $\int 8x^6 - x^4 - 7x^2 + 11x - 12 \, dx$

10. Determine $f(x)$ given that $f'(x) = 16x^4 - 9x^2 - x$.

11. Determine $g(t)$ given that $g'(t) = 4t^5 + 16t^2 - 18t + 72$.

12. Determine $R(z)$ given that $R'(z) = 4z^{15} + 121z^{10} + 20z^5 + z - 4$.

13. Determine $f(x)$ given that $f''(x) = 8x^3 - 12x + 3$.

5.2 Computing Indefinite Integrals

For problems 1 - 43 evaluate the given integral.

1. $\int 7x^5 - 5x^4 + 6x^2 - 14x + 3 dx$

2. $\int t^4 - 9t^3 + 12t^2 - 7t dt$

3. $\int 4 - 18w^{11} - 9w^9 + 8w^7 + 2w^5 dw$

4. $\int x^9 - 6x^4 - 21x^2 - 1 + 9x dx$

5. $\int -7 dz$

6. $\int 4 dw$

7. $\int 10z^{-6} + 8z^{-5} - z^{-2} + 1 dz$

8. $\int y^{-16} + 24y^{-12} - 14y^{-8} - 2y^{-4} dy$

9. $\int 2x^{-9} + 12x^{-5} + 7x^{-3} - x^{-2} dx$

10. $\int 5z^{-4} + 5z^4 - 9dz$

11. $\int 6t^3 + 8t^{-6} + t^{-10} dt$

12. $\int x^{-3} + 9x^2 + 11x^8 - 7x^{-12} dx$

13. $\int \sqrt[7]{w^2} + 3 - 9 \sqrt[3]{w^7} dw$

14. $\int w^5 + \sqrt{w^5} - \sqrt[5]{w} dw$

15. $\int 6 \sqrt[3]{v^2} - 7 \sqrt[4]{v} dv$

16. $\int \frac{6}{y^3} - \frac{1}{7y^6} + \frac{1}{y^2} dy$

17.
$$\int 8 + u^5 - \frac{1}{u^5} + \frac{1}{6u^5} du$$

18.
$$\int \frac{12}{x^5} + \frac{1}{4x^8} + \frac{6}{7x^2} dx$$

19.
$$\int \sqrt[3]{t^5} - \frac{1}{\sqrt{t^9}} + t^4 dt$$

20.
$$\int \frac{2}{z^6} - \frac{1}{5\sqrt[7]{z^8}} + 9 dz$$

21.
$$\int x^3 + \frac{1}{x^3} - \sqrt{x^3} dx$$

22.
$$\int x^6 (1 - 4x^2 + x^3) dx$$

23.
$$\int (6 - 2u)^2 du$$

24.
$$\int 2 - (3 + y)(4 - y^3) dy$$

25.
$$\int \sqrt{w} (\sqrt[3]{w} - \sqrt[4]{w}) dw$$

26.
$$\int 3v \left(v^2 - \frac{1}{6v^2} + \sqrt[3]{v^2} \right) dv$$

27.
$$\int \frac{8x^5 - 2x^3 + 7}{x^2} dx$$

28.
$$\int \frac{9 - z + 2z^4 + 10z^6}{z^4} dz$$

29.
$$\int \frac{2\sqrt{t} - 4t + \sqrt[3]{t}}{t^2} dt$$

30.
$$\int \frac{(1-x)(2+x)}{x} dx$$

31.
$$\int 6 \sin(t) - 2 \cos(t) dt$$

32.
$$\int \sec^2(u) + 7 \sec(u) \tan(u) du$$

33.
$$\int \csc^2(y) - \sec^2(y) dy$$

34.
$$\int 8 \cos(z) - 3 \csc(z) \cot(z) dz$$

35.
$$\int \tan(x) [\cot(x) - \cos(x)] dx$$

36.
$$\int \frac{\cos^3(v) + \sin(v)}{\cos^2(v)} dv$$

37.
$$\int w^2 + 2e^w dw$$

38.
$$\int e^t + \frac{2}{t} dt$$

39.
$$\int \frac{14}{x} - \frac{3}{x^2} dx$$

40.
$$\int e^{-u} (e^{2u} + e^u) du$$

41.
$$\int \frac{1}{7z} + \frac{1}{e^{-z}} + \frac{1}{4z^8} dz$$

42.
$$\int 1 + w^2 - \frac{6}{1+w^2} dw$$

43.
$$\int \frac{5}{1+t^2} + \frac{1}{10\sqrt{1-t^2}} dt$$

44. Determine $f(x)$ given that $f'(x) = 12x^5 + 30x^2$ and $f(4) = -23$.

45. Determine $h(z)$ given that $h'(z) = 12z^3 - 14z^2 + 10$ and $h(-1) = 8$.

46. Determine $g(v)$ given that $g'(v) = \frac{1}{2}v^{-\frac{1}{2}} - \frac{1}{4}v^{-\frac{3}{4}}$ and $g(16) = 1$.

47. Determine $P(t)$ given that $P'(t) = 6e^t - 4 - 10t$ and $P(0) = -6$.

48. Determine $g(x)$ given that $g''(x) = 12x^2 - 30x + 4$, $g(-1) = 7$ and $g(2) = 3$.

49. Determine $f(u)$ given that $f''(u) = 60u^4 - 60u^2$, $f(-1) = 14$ and $f'(1) = 6$.

50. Determine $h(t)$ given that $h''(t) = 6t - 14 + 9e^t$, $h(0) = 4$ and $h(3) = 9e^3 + 8$.

5.3 Substitution Rule for Indefinite Integrals

For problems 1 - 31 evaluate the given integral.

1. $\int 12v(7 + 6v^2)^9 dv$

2. $\int (4x^3 - 12x)(x^4 - 6x^2)^{-3} dx$

3. $\int (z^2 - 4)(12z - z^3)^4 dz$

4. $\int 7z^2(14 + 8z^3)^{-5} dz$

5. $\int 3(y^6 - 4y^{-3})(y^7 + 14y^{-2} - 7)^6 dy$

6. $\int \left(\frac{1}{2}x^3 - 1\right)\sqrt{8x - x^4} dx$

7. $\int (6w^{-4} + 12w^{-7})\sqrt[4]{w^{-3} + w^{-6}} dw$

8. $\int \cos(7t) dt$

9. $\int (v - 2v^3)\cos(v^2 - v^4) dv$

10. $\int \sqrt{z}\sin(1 + \sqrt{z^3}) dz$

11. $\int \csc^2(1 + 2x) dx$

12. $\int 7w^{-5}\sec(w^{-4})\tan(w^{-4}) dw$

13. $\int (2 - t^2)e^{6t-t^3} dt$

14. $\int 12z^{-2}e^{4+z^{-1}} dz$

15. $\int \frac{1}{4 - 9w} dw$

16. $\int \frac{9y}{y^2 + 3} dy$

17. $\int \frac{6x^2 - 10x^4}{x^5 - x^3} dx$
18. $\int \frac{1}{t} \sin(1 - \ln(t)) dt$
19. $\int [6v - 18 \sin(6v)] \sqrt[5]{v^2 + \cos(6v)} dv$
20. $\int e^{-3z} \sec(e^{-3z}) \tan(e^{-3z}) dz$
21. $\int (\cos(x) + \sin(x)) e^{\sin(x) - \cos(x)} dx$
22. $\int \frac{[\ln(w^2)]^4}{w} dw$
23. $\int \cos(v) \cos(1 + \sin(v)) dv$
24. $\int \frac{y + \sin(2y)}{y^2 - \cos(2y)} dy$
25. $\int \sec^7(t) \tan(t) dt$
26. $\int e^z \sec^2(e^z) [1 + \tan(e^z)]^{-3} dz$
27. $\int \frac{7}{1 + 5x^2} dx$
28. $\int \frac{2}{3 + 4t^2} dt$
29. $\int \frac{1}{\sqrt{16 - y^2}} dy$
30. $\int \frac{3}{\sqrt{7 - 4v^2}} dv$
31. $\int \frac{x}{1 + x^4} dx$

32. Evaluate each of the following integrals.

(a) $\int \frac{1}{3+x} dx$

(b) $\int \frac{x}{3+x^2} dx$

(c) $\int \frac{x}{(3+x^2)^7} dx$

(d) $\int \frac{1}{3+x^2} dx$

33. Evaluate each of the following integrals.

(a) $\int \frac{4w}{25+9w^2} dw$

(b) $\int \frac{4w}{(25+9w^2)^3} dw$

(c) $\int \frac{4}{25+9w^2} dw$

5.4 More Substitution Rule

Evaluate each of the following integrals.

$$1. \int 3x \cos(4 - x^2) - 8x\sqrt{4 - x^2} dx$$

$$2. \int \frac{4}{(9 + 6t)^5} + \frac{13}{9 + 6t} dt$$

$$3. \int (6 - 5w) e^{12w - 5w^2} + (20w - 24) \sec^2(12w - 5w^2) dw$$

$$4. \int \frac{\sin(1 + \ln(2x)) - \sqrt{1 + \ln(2x)}}{x} dx$$

$$5. \int 17(xe^x + e^x) \sin(xe^x) - 14 \sin(x) dx$$

$$6. \int \frac{1}{3t} + \sec(9t) \tan(9t) e^{\sec(9t)} dt$$

$$7. \int 8w^2 + \frac{\sin(w) + \cos(w)}{\sin(w) - \cos(w)} dw$$

$$8. \int 8 + (3 + x^6) \cos(21x + x^7) + 9x^2 - 4\sqrt{x} dx$$

$$9. \int \sin(y) \cos(y) \sqrt{3 + \sin^2(y)} + 5e^y dy$$

$$10. \int \sin(2 - t) + 8 \cos(5t) - e^{3t} dt$$

$$11. \int \frac{4x^2 - 1}{\sqrt[4]{6x - 8x^3}} + 9xe^{x^2} dx$$

$$12. \int z^3 + \sqrt{4 - 3z} - 4 \sec(8z) \tan(8z) dz$$

$$13. \int \frac{17}{6 - w} + \sin(w) \sin[1 + \cos(w)] dw$$

$$14. \int \frac{\sqrt{1 + 2 \ln(7x)}}{x} + \frac{10x^3}{x^4 + 9} dx$$

$$15. \int x \sin(x^2) [\cos^4(x^2) + 8 \cos^2(x^2) - 10] dx$$

$$16. \int \csc\left(\frac{t}{2}\right) \cot\left(\frac{t}{2}\right) \left[\csc^6\left(\frac{t}{2}\right) + 3 \csc^4\left(\frac{t}{2}\right) - 8 \csc\left(\frac{t}{2}\right) \right] dt$$

17.
$$\int \frac{3 + 7y}{y^2 + 3} dy$$

18.
$$\int \frac{15z + 27}{100z^2 + 11} dz$$

19.
$$\int \frac{8x + 1}{\sqrt{16 - x^2}} dx$$

20.
$$\int \frac{2 - w}{\sqrt{25 - 2w^2}} dw$$

21.
$$\int \frac{9z^5}{2 + 3z^3} dz$$

22.
$$\int 4t^{15} \sqrt{1 - t^8} dt$$

23.
$$\int \cot(x) dx$$

24.
$$\int \csc(x) dx$$

25.
$$\int \frac{x}{1 + x^4} dx$$

26.
$$\int \mathbf{e}^{8t} (4 + \mathbf{e}^{4t})^{-3} dt$$

27.
$$\int x^8 \sqrt{2 - x^3} dx$$

5.5 Area Problem

For problems 1 - 5 estimate the area of the region between the function and the x-axis on the given interval using $n = 6$ and using,

- (a) the right end points of the subintervals for the height of the rectangles,
- (b) the left end points of the subintervals for the height of the rectangles and,
- (c) the midpoints of the subintervals for the height of the rectangles.

1. $f(x) = 15 + 4x - x^3$ on $[1, 3]$
2. $g(x) = -3x^2 + 2x - 1$ on $[-4, 0]$
3. $h(x) = 8 \ln(x) - x$ on $[2, 6]$
4. $f(x) = \sin^2\left(\frac{x}{2}\right)$ on $[0, 3]$
5. $g(x) = \sin(x) \cos(x) - 1$ on $[-2, 1]$

For problems 6 - 8 estimate the net area between the function and the x-axis on the given interval using $n = 8$ and the midpoints of the subintervals for the height of the rectangles. Without looking at a graph of the function on the interval does it appear that more of the area is above or below the x-axis?

6. $h(x) = 8x - \sqrt{x+4}$ on $[-3, 2]$
7. $g(x) = 5 + x - x^2$ on $[0, 4]$
8. $f(x) = xe^{-x^2}$ on $[-1, 1]$

5.6 Definition of the Definite Integral

For problems 1 - 4 use the definition of the definite integral to evaluate the integral. Use the right end point of each interval for x_i^* .

1.
$$\int_{-2}^1 7 - 4x \, dx$$

2.
$$\int_0^2 3x^2 + 4x \, dx$$

3.
$$\int_{-1}^1 (x - 3)^2 \, dx$$

4.
$$\int_0^3 8x^3 + 3x - 2 \, dx$$

5. Evaluate :
$$\int_{-123}^{-123} \cos^6(2x) - \sin^8(4x) \, dx$$

For problems 6 - 8 determine the value of the given integral given that $\int_{-2}^5 f(x) \, dx = 1$ and $\int_{-2}^5 g(x) \, dx = 8$.

6.
$$\int_{-2}^5 -3g(x) \, dx$$

7.
$$\int_{-2}^5 7f(x) - \frac{1}{4}g(x) \, dx$$

8.
$$\int_5^{-2} 12g(x) - 3f(x) \, dx$$

9. Determine the value of $\int_7^{-1} f(x) \, dx$ given that $\int_{13}^7 f(x) \, dx = -9$ and $\int_{13}^{-1} f(x) \, dx = -12$.

10. Determine the value of $\int_0^6 4f(x) \, dx$ given that $\int_0^5 f(x) \, dx = 10$ and $\int_5^6 f(x) \, dx = 3$.

11. Determine the value of $\int_2^{10} f(x) \, dx$ given that $\int_2^4 f(x) \, dx = -1$, $\int_4^7 f(x) \, dx = 3$ and $\int_{10}^7 f(x) \, dx = -8$.

12. Determine the value of $\int_{-5}^{-1} f(x) dx$ given that $\int_2^{-5} f(x) dx = 56$, $\int_7^2 f(x) dx = -90$ and $\int_{-1}^7 f(x) dx = 45$.

For problems 13 - 17 sketch the graph of the integrand and use the area interpretation of the definite integral to determine the value of the integral.

13. $\int_{-2}^1 12 - 5x dx$

14. $\int_0^4 \sqrt{16 - x^2} dx$

15. $\int_{-3}^3 5 - \sqrt{9 - x^2} dx$

16. $\int_{-1}^3 8x - 3 dx$

17. $\int_1^6 |x - 3| dx$

For problems 18 - 23 differentiate each of the following integrals with respect to x.

18. $\int_{-8}^x e^{\cos(t)} dt$

19. $\int_2^{x^2} \sqrt{\cos(t) + 3} dt$

20. $\int_0^{e^{3x}} \frac{1}{t^4 + t^2 + 1} dt$

21. $\int_{\sin(9x)}^8 \frac{e^t}{7t} dt$

22. $\int_{x^3}^x \cos^4(t) - \sin^2(t) dt$

23. $\int_{9x}^{\tan(x)} \frac{\cos(t) + 2}{\sin(t) + 4} dt$

24. Evaluate the limit : $\lim_{x \rightarrow 0} \frac{\int_0^x e^{t^2} dt}{x}$

5.7 Computing Definite Integrals

1. Evaluate each of the following integrals.

(a) $\int 3z^2 - 4 + \frac{4}{z^2} dz$

(b) $\int_1^4 3z^2 - 4 + \frac{4}{z^2} dz$

(c) $\int_{-2}^1 3z^2 - 4 + \frac{4}{z^2} dz$

2. Evaluate each of the following integrals.

(a) $\int 6x + \frac{1}{3x} dx$

(b) $\int_0^7 6x + \frac{1}{3x} dx$

(c) $\int_3^7 6x + \frac{1}{3x} dx$

3. Evaluate each of the following integrals.

(a) $\int \sin(y) + \sec^2(y) dy$

(b) $\int_0^{\frac{\pi}{4}} \sin(y) + \sec^2(y) dy$

(c) $\int_0^{\frac{2\pi}{3}} \sin(y) + \sec^2(y) dy$

Evaluate each of the following integrals, if possible. If it is not possible clearly explain why it is not possible to evaluate the integral.

4. $\int_0^3 10t - 6t^2 + 9 dt$

5. $\int_{-1}^4 24z^2 + 5z^4 dz$

6. $\int_1^0 9w - 3w^2 + 4w^3 dw$

7. $\int_{-3}^{-1} 15t^2 - 10t - 2dt$

8.
$$\int_{-2}^4 v^3 - 7v^2 + 3v \, dv$$

9.
$$\int_0^{16} 9\sqrt{x} + 10\sqrt[4]{x} \, dx$$

10.
$$\int_{-1}^2 8\sqrt[3]{z} - 12\sqrt[5]{z} \, dz$$

11.
$$\int_1^4 \sqrt{y^5} - \frac{1}{\sqrt[3]{y}} \, dy$$

12.
$$\int_1^4 \frac{6}{x^3} - \frac{1}{3x^2} \, dx$$

13.
$$\int_6^{-3} 8w^3 - 25w^4 + \frac{4}{3w^5} \, dw$$

14.
$$\int_{-1}^{-3} \frac{4}{3z^2} - \frac{6}{z^3} \, dz$$

15.
$$\int_0^6 (3-t)(2t^2+3) \, dt$$

16.
$$\int_4^1 \sqrt{x}(x-2x^2+1) \, dx$$

17.
$$\int_2^5 \frac{6z^5 - 8z^4 + 2z^2}{z^4} \, dz$$

18.
$$\int_{-2}^{-4} \frac{9x^4 - 8x^3 + x}{3x^2} \, dx$$

19.
$$\int_{-8}^2 \frac{7v^{10} + 4v^6 - 3v^2}{v^5} \, dv$$

20.
$$\int_1^2 \frac{(y-2)(y+2)}{y^2} \, dy$$

21.
$$\int_0^{\frac{\pi}{4}} 8\sec^2(t) + 2\sec(t)\tan(t) \, dt$$

22.
$$\int_{-\frac{\pi}{3}}^{\frac{\pi}{6}} 3\cos(w) + \sin(w) \, dw$$

23.
$$\int_{-\frac{\pi}{4}}^{\frac{\pi}{4}} 12\sec^2(y) - 9\csc^2(y) \, dy$$

24.
$$\int_{\frac{2\pi}{3}}^{\frac{\pi}{4}} 3 \sin(v) + 8 \csc(v) \cot(v) dv$$

25.
$$\int_{-3}^1 4x - 7e^x dx$$

26.
$$\int_{-2}^1 \frac{4e^{2w} + 4w e^w}{e^w} dw$$

27.
$$\int_0^{\frac{1}{2}} \frac{3}{\sqrt{1-x^2}} + \frac{7}{x^2+1} dx$$

28.
$$\int_{-2}^3 5 \sin(t) + \frac{1}{\sqrt{1-t^2}} dt$$

29.
$$\int_6^{10} \frac{4}{z} + \frac{1}{2z^2} dz$$

30.
$$\int_1^6 2x^3 + \frac{3}{8x} dx$$

31.
$$\int_{-4}^{-1} f(t) dt \text{ where } f(t) = \begin{cases} 9 + 6t^2 & t > -3 \\ 8t & t \leq -3 \end{cases}$$

32.
$$\int_{-2}^4 g(x) dx \text{ where } g(x) = \begin{cases} 9 - 2e^x & x > 0 \\ 8 \sin(x) & x \leq 0 \end{cases}$$

33.
$$\int_4^9 h(w) dw \text{ where } h(w) = \begin{cases} 4 & w > 6 \\ 3w + 1 & w \leq 6 \end{cases}$$

34.
$$\int_{-1}^7 f(x) dx \text{ where } f(x) = \begin{cases} 9x^2 & x > 5 \\ -7 & 1 < x \leq 5 \\ 3 - 8x & x \leq 1 \end{cases}$$

35.
$$\int_{-3}^1 |8 + 4x| dx$$

36.
$$\int_2^8 |3v - 12| dv$$

37.
$$\int_0^6 |10 - 2z| dz$$

38.
$$\int_{-3}^6 |t^2 - 4| dt$$

5.8 Substitution Rule for Definite Integrals

Evaluate each of the following integrals, if possible. If it is not possible clearly explain why it is not possible to evaluate the integral.

1.
$$\int_{-2}^3 \frac{4}{(5+2x)^3} dx$$

2.
$$\int_1^0 10(1-2w^2) \sqrt[4]{7-3w+2w^3} dw$$

3.
$$\int_{-1}^4 (t-2)e^{t^2-4t} dt$$

4.
$$\int_1^6 7 \cos\left(\frac{\pi z}{2}\right) \left(4 + \sin\left(\frac{\pi z}{2}\right)\right)^5 dz$$

5.
$$\int_0^1 \frac{w^3}{6w^4+3} dw$$

6.
$$\int_{-1}^1 x^2 \cos(x^3+2) - x^2 e^{x^3+2} dx$$

7.
$$\int_0^{\frac{\pi}{3}} \frac{4 \sin(3t)}{2 + \cos(3t)} + \frac{7 \sin(3t)}{(2 + \cos(3t))^2} dt$$

8.
$$\int_0^{\pi} \sec^2(y) \sqrt{2 + \tan(y)} dy$$

9.
$$\int_1^9 \sqrt{x^5} + \frac{\sin(\sqrt{x})}{\sqrt{x}} dx$$

10.
$$\int_0^1 \sec^2(w) - \frac{2}{4w^2+1} dw$$

11.
$$\int_3^0 e^{-4t} \sqrt{2 + e^{-4t}} + 8e^t dt$$

12.
$$\int_3^7 \frac{9e^x}{e^x+4} + \frac{[\ln(2x)]^2}{x} dx$$

13.
$$\int_0^{\pi} \sin\left(\frac{v}{2}\right) \left[6 + 3\cos^2\left(\frac{v}{2}\right) - 4\cos^4\left(\frac{v}{2}\right)\right] dv$$

14.
$$\int_1^2 e^{-t} + 3te^{5-t^2} dt$$

15.
$$\int_0^6 \frac{8t^3}{2t^4+1} - \frac{7t}{t^2-9} dt$$

16.
$$\int_2^6 \sqrt{1+2y} + (4-y)(y^2-8y+5)^4 dy$$

17.
$$\int_0^1 e^{2z} \sin(e^{2z}-1) + \sin(z) e^{2-\cos(z)} dz$$

6 Applications of Integrals

The previous chapter dealt exclusively with the computation of definite and indefinite integrals as well as some discussion of their properties and interpretations. It is now time to start looking at some applications of integrals. Note as well that we should probably say applications of **definite** integrals as that is really what we'll be looking at in this section.

In addition, we should note that there are a lot of different applications of (definite) integrals out there. We will look at the ones that can easily be done with the knowledge we have at our disposal at this point. Once we have covered the next chapter, [Integration Techniques](#), we will be able to take a look at a few more applications of integrals. At this point we would not be able to compute many of the integrals that arise in those later applications.

In this chapter we'll take a look at using integrals to compute the average value of a function and the work required to move an object over a given distance. In addition we will take a look at a couple of geometric applications of integrals. In particular we will use integrals to compute the area that is between two curves and note that this application should not be too surprising given one of the major interpretations of the definite integral. We will also see how to compute the volume of some solids. We will compute the volume of solids of revolution, *i.e.* a solid obtained by rotating a curve about a given axis. In addition, we will compute the volume of some slightly more general solids in which the cross sections can be easily described with nice 2D geometric formulas (*i.e.* rectangles, triangles, circles, *etc.*).

If you are looking for some practice problems (with solutions available) please check out the [Practice Problems](#). There you will find a set of problems that should give you quite a bit practice.

6.1 Average Function Value

For problems 1 - 4 determine f_{avg} for the function on the given interval.

1. $f(x) = 8x^4 - 7x^3 + 2$ on $[-2, 1]$
2. $f(x) = (4 - x)e^{x^2 - 8x}$ on $[1, 4]$
3. $f(x) = 6x - \frac{4x}{x^2 + 1}$ on $[-3, 0]$
4. $f(x) = \cos(3x)[2 + \sin(3x)]^4$ on $[0, \frac{\pi}{6}]$

For problems 5 - 8 find f_{avg} for the function on the given interval and determine the value of c in the given interval for which $f(c) = f_{\text{avg}}$.

5. $f(x) = 10 - 4x - 6x^2$ on $[2, 6]$
6. $f(x) = 7x^2 + 2x - 3$ on $[-1, 1]$
7. $f(x) = 9 - 2e^{4x+1}$ on $[-1, 2]$
8. $f(x) = 8 - \cos(\frac{x}{4})$ on $[0, 4\pi]$

6.2 Area Between Curves

1. Determine the area below $f(x) = 8x - 2x^2$ and above the x-axis.
2. Determine the area above $f(x) = 3x^2 + 6x - 9$ and below the x-axis.
3. Determine the area to the right of $g(y) = y^2 + 4y - 5$ and to the left of the y-axis.
4. Determine the area to the left of $g(y) = -4y^2 + 24y - 20$ and to the right of the y-axis.
5. Determine the area below $f(x) = 10 - 2x^2$ and above the line $y = 3$.
6. Determine the area above $f(x) = x^2 + 2x + 3$ and below the line $y = 11$.
7. Determine the area to the right of $g(y) = y^2 + 2y - 4$ and to the left of the line $x = -1$.
8. Determine the area to the left of $g(y) = 2 + 4y - y^2$ and to the right of the line $x = -1$.

For problems 9 - 26 determine the area of the region bounded by the given set of curves.

9. $y = x^3 + 2$, $y = 1$ and $x = 2$.
10. $y = x^2 - 6x + 10$ and $y = 5$.
11. $y = x^2 - 6x + 10$, $x = 1$, $x = 5$ and the x-axis.
12. $x = y^2 + 2y + 4$ and $x = 4$.
13. $y = 5 - \sqrt{x}$, $x = 1$, $x = 4$ and the x-axis.
14. $x = e^y$, $x = 1$, $y = 1$ and $y = 2$.
15. $x = 4y - y^2$ and the y-axis.
16. $y = x^2 + 2x + 4$, $y = 3x + 6$, $x = -3$ and $x = 3$.
17. $x = 6y - y^2$, $x = 2y$, $y = -2$ and $y = 5$.
18. $y = x^2 + 8$, $y = 3x^2$, $x = -3$ and $x = 4$.
19. $x = y^2$, $x = y^3$ and $y = 2$.
20. $y = \frac{7}{x}$, $y = \frac{1}{x} - 3$, $x = -1$ and $x = -4$.
21. $y = 2x^2 + 1$, $y = 7 - x$, $x = 4$ and the y-axis.
22. $y = \sin\left(\frac{1}{2}x\right)$, $y = 3 + \cos(2x)$, $x = 0$ and $x = \frac{\pi}{4}$.

23. $x = \sqrt{2y+6}$, $x = y - 1$, $y = 1$ and $y = 6$.

24. $y = 2 - e^{2-x}$, $y = x^2 - 4x + 7$, $x = 3$ and the y-axis. Note : These functions do not intersect.

25. $y = e^{2x-1}$, $y = e^{5-x}$, $x = 0$ and $x = 3$.

26. $x = \cos(\pi y)$, $x = 3$, $y = 0$ and $y = 4$.

6.3 Solids of Revolution / Method of Rings

For problems 1 - 16 use the method disks/rings to determine the volume of the solid obtained by rotating the region bounded by the given curves about the given axis.

1. Rotate the region bounded by $y = 2x^2$, $y = 8$ and the y -axis about the y -axis.
2. Rotate the region bounded by $y = 2x^2$, $y = 8$ and the y -axis about the x -axis.
3. Rotate the region bounded by $y = 2x^2$, $x = 2$ and the x -axis about the x -axis.
4. Rotate the region bounded by $y = 2x^2$, $x = 2$ and the x -axis about the y -axis.
5. Rotate the region bounded by $x = y^3$, $x = 8$ and the x -axis about the x -axis.
6. Rotate the region bounded by $x = y^3$, $x = 8$ and the x -axis about the y -axis.
7. Rotate the region bounded by $x = y^3$, $y = 2$ and the y -axis about the x -axis.
8. Rotate the region bounded by $x = y^3$, $y = 2$ and the y -axis about the y -axis.
9. Rotate the region bounded by $y = \frac{1}{x^2}$, $y = 9$, $x = -2$, $x = -\frac{1}{3}$ about the y -axis.
10. Rotate the region bounded by $y = \frac{1}{x^2}$, $y = 9$, $x = -2$, $x = -\frac{1}{3}$ about the x -axis.
11. Rotate the region bounded by $y = 4 + 3e^{-x}$, $y = 2$, $x = \frac{1}{2}$ and $x = 3$ about the x -axis.
12. Rotate the region bounded by $x = 5 - y^2$ and $x = 4$ about the y -axis.
13. Rotate the region bounded by $y = 6 - 2x$, $y = 3 + x$ and $x = 3$ about the x -axis.
14. Rotate the region bounded by $y = 6 - 2x$, $y = 3 + x$ and $y = 6$ about the y -axis.
15. Rotate the region bounded by $y = x^2 - 2x + 4$ and $y = x + 14$ about the x -axis.
16. Rotate the region bounded by $x = (y - 3)^2$ and $x = 16$ about the y -axis.
17. Use the method of disks/rings to determine the volume of the solid obtained by rotating the region bounded by $y = 2x^2$, $y = 8$ and the y -axis about the

(a) line $x = 3$	(b) line $x = -2$	(c) line $y = 11$	(d) line $y = -4$
-------------------------	--------------------------	--------------------------	--------------------------
18. Use the method of disks/rings to determine the volume of the solid obtained by rotating the region bounded by $x = y^2 - 6y + 9$ and $x = -y^2 + 6y - 1$ about the

(a) line $x = 10$	(b) line $x = -3$
--------------------------	--------------------------

19. Use the method of disks/rings to determine the volume of the solid obtained by rotating the triangle with vertices $(3, 2)$, $(7, 2)$ and $(7, 14)$ about the
- (a) line $x = 12$ (b) line $x = 2$ (c) line $x = -1$
(d) line $y = 14$ (e) line $y = 1$ (f) line $y = -3$
20. Use the method of disks/rings to determine the volume of the solid obtained by rotating the region bounded by $y = 4 + 3e^{-x}$, $y = 2$, $x = \frac{1}{2}$ and $x = 3$ about the
- (a) line $y = 7$ (b) line $y = 1$ (c) line $y = -3$
21. Use the method of disks/rings to determine the volume of the solid obtained by rotating the region bounded by $x = 3 + y^2$ and $x = 2y + 11$ about the
- (a) line $x = 23$ (b) line $x = 2$ (c) line $x = -1$
22. Use the method of disks/rings to determine the volume of the solid obtained by rotating the region bounded by $y = 5 + \sqrt{x}$, $y = 5$ and $x = 4$ about the
- (a) line $y = 8$ (b) line $y = 2$ (c) line $y = -2$
23. Use the method of disks/rings to determine the volume of the solid obtained by rotating the region bounded by $y = 10 - 2x$, $y = x + 1$ and $y = 7$ about the
- (a) line $x = 8$ (b) line $x = 1$ (c) line $x = -4$
24. Use the method of disks/rings to determine the volume of the solid obtained by rotating the region bounded by $y = -x^2 - 2x - 5$ and $y = 2x - 17$ about the
- (a) line $y = 3$ (b) line $y = -1$ (c) line $y = -34$
25. Use the method of disks/rings to determine the volume of the solid obtained by rotating the region bounded by $x = -2y^2 - 3$ and $x = -5$ about the
- (a) line $x = 4$ (b) line $x = -2$ (c) line $x = -9$

6.4 Solids of Revolution / Method of Cylinders

For problems 1 - 14 use the method cylinders to determine the volume of the solid obtained by rotating the region bounded by the given curves about the given axis.

1. Rotate the region bounded by $y = 2x^2$, $y = 8$ and the y -axis about the y -axis.
2. Rotate the region bounded by $y = 2x^2$, $y = 8$ and the y -axis about the x -axis.
3. Rotate the region bounded by $y = 2x^2$, $x = 2$ and the x -axis about the x -axis.
4. Rotate the region bounded by $y = 2x^2$, $x = 2$ and the x -axis about the y -axis.
5. Rotate the region bounded by $x = y^3$, $x = 8$ and the x -axis about the x -axis.
6. Rotate the region bounded by $x = y^3$, $x = 8$ and the x -axis about the y -axis.
7. Rotate the region bounded by $x = y^3$, $y = 2$ and the y -axis about the x -axis.
8. Rotate the region bounded by $x = y^3$, $y = 2$ and the y -axis about the y -axis.
9. Rotate the region bounded by $y = \frac{1}{x}$, $y = \frac{1}{3}$ and $x = \frac{1}{2}$ about the y -axis.
10. Rotate the region bounded by $y = \frac{1}{x}$, $y = \frac{1}{3}$ and $x = \frac{1}{2}$ about the x -axis.
11. Rotate the region bounded by $y = 6 - 2x$, $y = 3 + x$ and $x = 3$ about the y -axis.
12. Rotate the region bounded by $y = 6 - 2x$, $y = 3 + x$ and $y = 6$ about the x -axis.
13. Rotate the region bounded by $y = x^2 - 6x + 11$ and $y = 6$ about the y -axis.
14. Rotate the region bounded by $x = y^2 - 8y + 19$ and $x = 2y + 3$ about the x -axis.
15. Use the method of cylinders to determine the volume of the solid obtained by rotating the region bounded by $y = 2x^2$, $y = 8$ and the y -axis about the
 - (a) line $x = 3$
 - (b) line $x = -2$
 - (c) line $y = 11$
 - (d) line $y = -4$
16. Use the method of cylinders to determine the volume of the solid obtained by rotating the region bounded by $x = y^3$, $x = 8$ and the x -axis about the
 - (a) line $x = 10$
 - (b) line $x = -3$
 - (c) line $y = 3$
 - (d) line $y = -4$
17. Use the method of cylinders to determine the volume of the solid obtained by rotating the region bounded by $x = y^2 - 6y + 9$ and $x = -y^2 + 6y - 1$ about the
 - (a) line $y = 7$
 - (b) line $y = -2$

18. Use the method of cylinders to determine the volume of the solid obtained by rotating the triangle with vertices $(3, 2)$, $(7, 2)$ and $(7, 14)$ about the
- (a) line $x = 12$ (b) line $x = 2$ (c) line $x = -1$
(d) line $y = 14$ (e) line $y = 1$ (f) line $y = -3$
19. Use the method of cylinders to determine the volume of the solid obtained by rotating the region bounded by $y = 4 + 3e^{-x}$, $y = 2$, $x = \frac{1}{2}$ and $x = 3$ about the
- (a) line $x = 5$ (b) line $x = \frac{1}{4}$ (c) line $x = -1$
20. Use the method of cylinders to determine the volume of the solid obtained by rotating the region bounded by $x = y^2 - 8y + 19$ and $x = 2y + 3$ about the
- (a) line $y = 9$ (b) line $y = 1$ (c) line $y = -3$
21. Use the method of cylinders to determine the volume of the solid obtained by rotating the region bounded by $y = 5 + \sqrt{x - 3}$, $y = 5$ and $x = 4$ about the
- (a) line $x = 9$ (b) line $x = 2$ (c) line $x = -1$
22. Use the method of cylinders to determine the volume of the solid obtained by rotating the region bounded by $y = -x^2 - 10x + 6$ and $y = 2x + 26$ about the
- (a) line $x = 2$ (b) line $x = -1$ (c) line $x = 14$
23. Use the method of cylinders to determine the volume of the solid obtained by rotating the region bounded by $x = y^2 - 10y + 27$ and $x = 11$ about the
- (a) line $y = 10$ (b) line $y = 1$ (c) line $y = -3$
24. Use the method of cylinders to determine the volume of the solid obtained by rotating the region bounded by $y = 2x^2 + 1$, $y = 7 - x$, $x = 3$ and $x = \frac{3}{2}$ about the
- (a) line $x = 6$ (b) line $x = 1$ (c) line $x = -2$

6.5 More Volume Problems

1. Use the method of finding volume from this section to determine the volume of a sphere of radius r .
2. Find the volume of the solid whose base is the region bounded by $x = 2 - y^2$ and $x = y^2 - 2$ and whose cross-sections are squares with the base perpendicular to the y -axis. See figure below to see a sketch of the cross-sections.

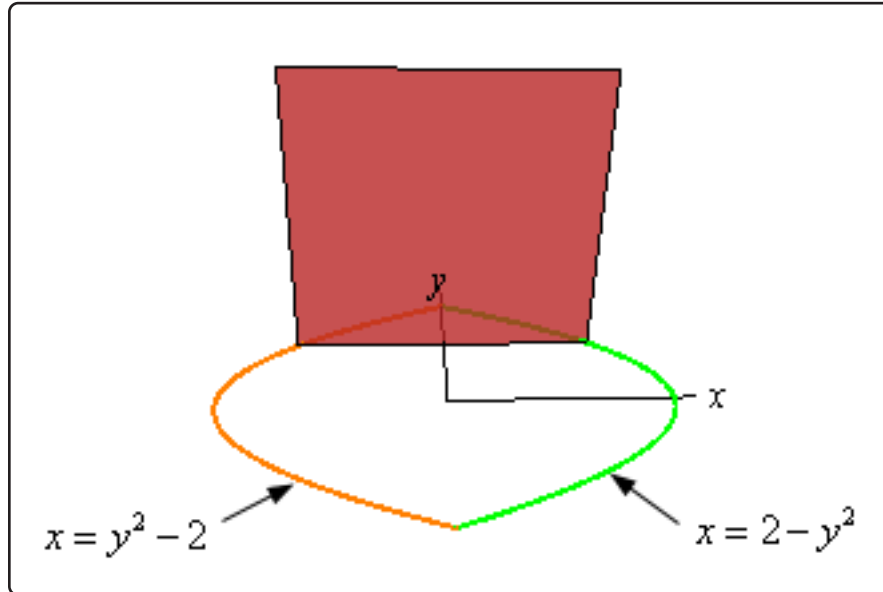

3. Find the volume of the solid whose base is a disk of radius r and whose cross-sections are rectangles whose height is half the length of the base and whose base is perpendicular to the x -axis. See figure below to see a sketch of the cross-sections (the positive x -axis and positive y -axis are shown in the sketch).

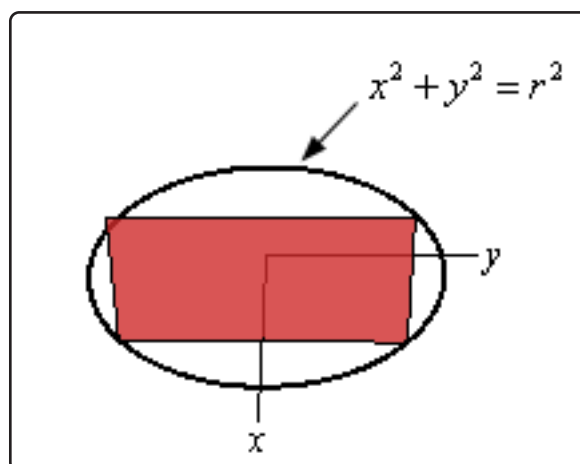

4. Find the volume of the solid whose base is the region bounded by $y = x^2 - 1$ and $y = 3$ and whose cross-sections are equilateral triangles with the base perpendicular to the y -axis. See figure below to see a sketch of the cross-sections.

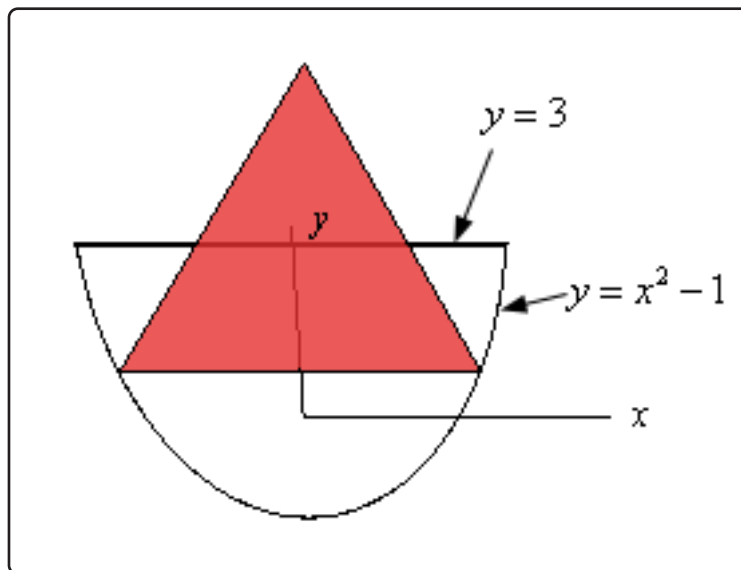

5. Find the volume of the solid whose base is the region bounded by $x = 2 - y^2$ and $x = y^2 - 2$ and whose cross-sections are the upper half of the circle centered on the y -axis. See figure below to see a sketch of the cross-sections.

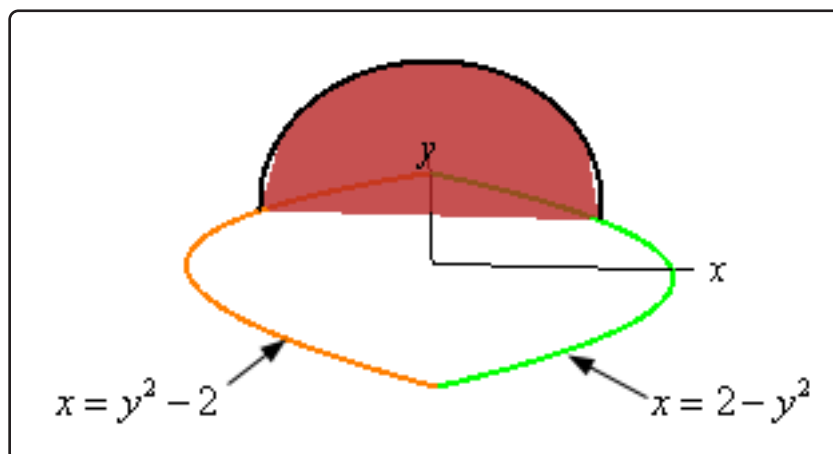

6. Find the volume of a wedge cut out of a “cylinder” whose base is the region bounded by $y = \cos(x)$ and the x -axis between $-\frac{\pi}{2} \leq x \leq \frac{\pi}{2}$. The angle between the top and bottom of the wedge is $\frac{\pi}{4}$. See the figure below for a sketch of the “cylinder” and the wedge (the positive x -axis and positive y -axis are shown in the sketch).

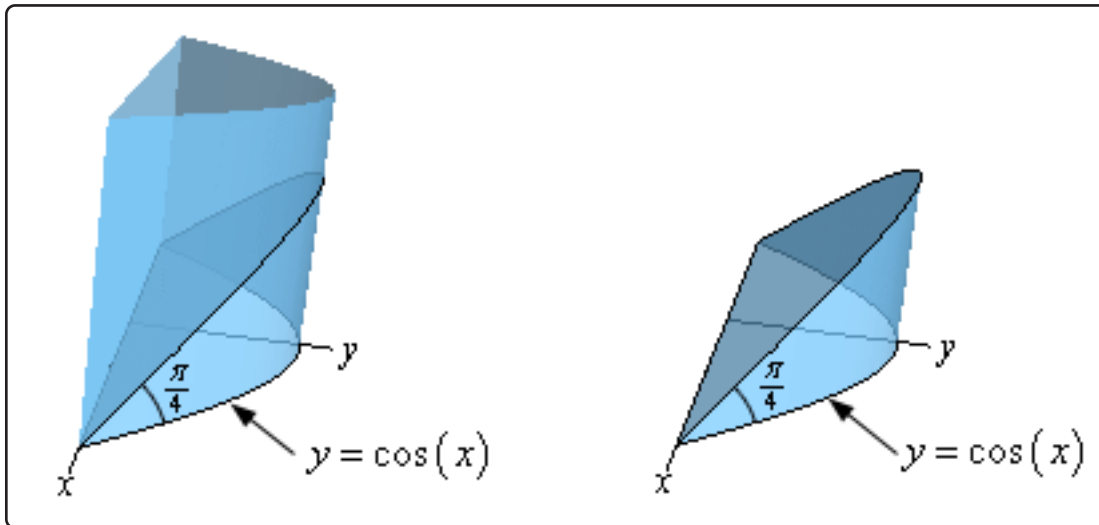

7. For a sphere of radius r find the volume of the cap which is defined by the angle φ where φ is the angle formed by the y -axis and the line from the origin to the bottom of the cap. See the figure below for an illustration of the angle φ .

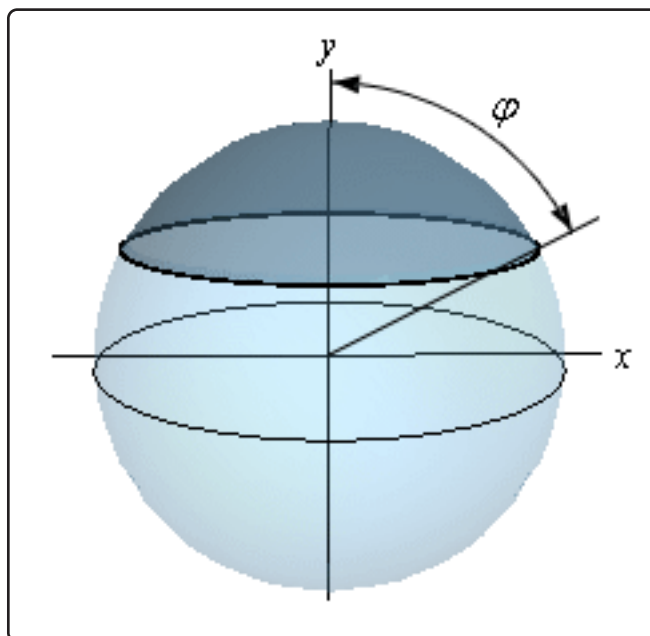

6.6 Work

1. A force of $F(x) = xe^{-2x^2} + 6x - 2$ acts on an object. What is the work required to move the object from $x = 1$ to $x = 4$?
2. A force of $F(x) = 4 \cos(2x) - 7 \sin\left(\frac{1}{2}x\right)$, x is in meters, acts on an object. What is the work required to move the object 10 meters to the right of $x = 2$?
3. A force of $F(x) = \sin(x)e^{\cos(x)} - 4x + 1$, x is in meters, acts on an object. What is the work required to move the object 6.5 meters to the left of $x = 9$?
4. A spring has a natural length of 25 cm and a force of 3.5 N is required to stretch and hold the spring to a length of 32 cm. What is the work required to stretch the spring from a length of 30 cm to a length of 45 cm?
5. A spring has a natural length of 9 inches and a force of 7 lbs is required to stretch and hold the spring to a length of 21 inches. What is the work required to stretch the spring from a length of 12 inches to a length of 30 inches?
6. A cable with mass 2 kg/meter is lifting a load of 50 kg that is initially at the bottom of a 75 meter shaft. How much work is required to lift the load 40 meters?
7. A cable with mass 1.5 kg/meter is attached to a bucket that has mass 75 kg. Initially there is 500 kg of grain in the bucket and as the bucket is raised 2 kg of grain leaks out of a hole in the bucket for every meter the bucket is raised. The bucket is 200 meters below a bridge. How much work is required to raise the bucket to the top of the bridge?
8. A tank of water is in the shape of a cylinder of height 25 meters and radius of 7 meters. If the tank is completely filled with water how much work is required to pump all of the water to the top of the tank. Assume that the density of water is 1000 kg/m^3 .
9. A tank of water is in the shape of an inverted pyramid that is 18 feet tall and whose top is a square with sides 4 feet long. If there is initially 12 feet of water in the tank determine the amount of work needed to pump all of the water to the top of the tank. Assume that the density of water is 62 lb/ft^3 .
10. A tank of is the shape of the lower half of a sphere of radius 6 meters. If the initial depth of the water is 4 meters how much work is required to pump all the water to the top of the tank. Assume that the density of water is 1000 kg/m^3 .

7 Integration Techniques

By this point we've now looked at basic integration techniques. We've seen how to integrate most of the "basic" functions we're liable to run into : polynomials, roots, trig, exponential, logarithm and inverse trig functions to name a few. In addition, we've seen how to do basic u -substitutions allowing us to integrate some more complicated functions.

We've also taken a look at some basic applications of (definite) integrals. However, as was noted at the time, there are applications of (definite) integrals that will, on occasion, have integrals that need more than just a basic u -substitution. So, before we can take a look at those applications we'll need to first talk about some more involved integration techniques.

Before getting into the new techniques we first need to make it clear that in this chapter it is assumed at you are comfortable with basic integration, including u -substitutions. Many of the problems in this chapter will not have a lot, if any, discussion of the basic integration work under the assumption that you are comfortable enough with the basic work that discussion is simply not needed. In addition, we will usually, although not always, give the substitution that we're using for the u -substitution but we will generally not show the actual substitution work. Again, this is under the assumption that you are comfortable enough with basic u -substitutions that you can fill in the details if you need to.

The reason for skipping the discussion of the basic integration work and/or not showing the full substitution work is so we can concentrate our discussion on the particular method that we are covering in that particular section. This is not to "punish" you but simply to acknowledge that we only have so much time in which to discuss the material and just can't afford to spend a lot of time basically re-lecturing basic integration material. We realize that, for many of you, this is the start of your Calculus II course and so you may have had some time off and may well have some "rust" on your basic integration skills. This is a warning to start scraping that rust off. If you need do scrape some rust off you can check out the [practice problems](#) for some practice problems covering basic integration to refresh your memory on how basic integration works.

It is also very important for you to understand that most of the problems we'll be looking at in this chapter will involve u -substitutions in one way or another. In fact, many of the techniques in this chapter are really just substitutions. The only difference is that either they need a fair amount of work to get to the point where the substitutions can be used or they will involve substitutions used in ways that we've not seen to this point. So, again, if you have some rust on your u -substitution skills you'll need to get it scraped off so you can do the work in this chapter.

In addition, we will be doing indefinite integrals almost exclusively in most of the sections in this

chapter. There are a few sections where we'll be doing some definite integrals but for the most part we'll keep the problems in most of the sections shorter by just doing indefinite integrals. It is assumed that if you were given a definite integral you could do the extra evaluation steps needed to finish the definite integral. Having said that, there are a few sections where definite integrals are done either because there are some subtleties that need to be dealt with for definite integrals or because the topic at hand, the last few sections in particular, involve only definite integrals.

So, with all that out of the way, here is a quick rundown of the new integration techniques we'll take a look at in this section.

Probably the most important technique, in this sense that it will be the most commonly seen technique out of this class, is integration by parts. This is the one new technique in this chapter that is not just u -substitutions done in new ways. Integration by Parts will involve u -substitutions at various steps the process on occasion but it will not be just a new way of doing a u -substitution.

As noted a lot of the techniques in this chapter are really just u -substitutions except they will need some manipulation of the integrand prior to actually doing the substitution. The techniques using this idea will include integrating some, but not all, products and quotients of trig functions, some integrands involving roots or quadratics that can't be done without manipulation of the integrand or "different" u -substitutions that we are used to. We'll also see how to use partial fractions to write some integrands involving rational expressions into a form that we can actually do the integral.

We'll also take a look at something called trig substitutions. This is probably the one technique that most find the most difficult, or at the least, the longest method. As we'll see a trig substitution is really a substitution but it is not a traditional u -substitution. However, having said that, if you understand how basic u -substitutions work it will help greatly when it comes to working with trig substitutions as the basic concepts are the same.

Next we'll be taking a look at a new kind of integral, Improper Integrals. This topic will address how to deal with definite integrals for which one or both of the limits of integration will be an infinity. In addition, we'll see how we can, on occasion, deal with discontinuities in the integrand (we'll focus on division by zero in the integrand).

We'll close out the section with a quick section on approximating the value of definite integrals.

We will leave this section with a warning. It is with this chapter that you will find that you can't just memorize your way through the class anymore. We will acknowledge that up to this point it is possible, for the most part, to just memorize your way through the class. You may not get the highest grades through just memorization as there are some topics that require a fair amount of understanding of the topic, but you can survive up to this point if you're really good at memorization.

Integration by Parts is a really good example of this. While you will need to memorize/know the basic integration by parts formula simply memorizing that will not help you to actually use integration by parts on the problem. You will need to actually understand how integration by parts works and how to "assign" various portions of the integrand to the various portions of the integration parts formula.

Also while there are some basic formulas we can, and do on occasion, give for some of the methods there are also situations that just don't fit into those formulas and so again you'll really need to understand how to do those methods in order to work problems for which basic formulas just won't work. Or, again, you can't just memorize your way out of most the methods taught in this chapter. Memorization may allow you to get through the basic problems but will not help all that much with more complicated problems.

Finally, we also need to warn you about seeing "patterns" and just assuming that all the problems will fall into those patterns. Integration by Parts is, again, a good example of this. There are some "patterns" that seem to show up because a lot of the problems we do in that section do fall into the patterns. The problem is that there are also some problems for which the "patterns" simply don't work and yet they still require integration by parts. If you get so locked into "patterns" you'll find it all but impossible to do some problems because they simply don't fall into those patterns.

This is not to say that recognizing that patterns in always a bad thing. Patterns do, on occasion, show up and they can be useful to understand/know as a possible solution method. However, you also need to always remember that there are problems that just don't fit easily into the patterns. This is also a warning that will be valid in other chapters in a typical Calculus II course as well. Again, patterns aren't bad per se, you just need to be careful to not always assume that every problem will fall into the patterns.

If you are looking for some practice problems (with solutions available) please check out the [Practice Problems](#). There you will find a set of problems that should give you quite a bit practice.

7.1 Integration by Parts

Evaluate each of the following integrals.

1. $\int 8t e^{7t} dt$

2. $\int_{\pi}^{2\pi} (1 - 3x) \sin\left(\frac{1}{2}x\right) dx$

3. $\int_{-1}^2 w^2 e^{4w} dw$

4. $\int_1^3 (2 - x)^2 \ln(4x) dx$

5. $\int (6 + 3z) \cos(1 + 4z) dz$

6. $\int 2y^2 \cos(9y) dy$

7. $\int (3z + z^2) \sin(z) dz$

8. $\int \sqrt{x^3} \ln(\sqrt[3]{x}) dx$

9. $\int (2w^2 - w) e^{7w-1} dw$

10. $\int 9t \sec^2(2t) dt$

11. $\int_0^{\frac{\pi}{8}} e^{-x} \sin(4x) dx$

12. $\int 8 \tan^{-1}(2y) dy$

13. $\int e^{6t} \cos(2t) dt$

14. $\int -3 \sin^{-1}(10x) dx$

15. $\int e^{3-z} \sin(2+z) dz$

16. $\int_{-1}^0 2x^{17} e^{1+x^9} dx$

17.
$$\int 9t^{11} \cos(1 - t^6) dt$$

18.
$$\int \frac{x^7}{\sqrt{x^4 + 1}} dx$$

19.
$$\int (5 + x^4) \sin\left(\frac{1}{2}x\right) dx$$

20.
$$\int 2z^5 e^{1-z} dz$$

21.
$$\int (5 + 2w^3 - w^5) \cos(3w) dw$$

7.2 Integrals Involving Trig Functions

Evaluate each of the following integrals.

1. $\int \cos^5(2t) \sin^2(2t) dt$

2. $\int \cos^3(12x) dx$

3. $\int \cos^2(z) \sin^4(z) dz$

4. $\int_{\frac{\pi}{3}}^{\pi} \sin^5\left(\frac{3}{4}w\right) \cos^6\left(\frac{3}{4}w\right) dw$

5. $\int_0^{\pi} \cos^{11}(5z) \sin^3(5z) dz$

6. $\int \sin^2(7x) dx$

7. $\int_0^{\frac{\pi}{6}} \tan^3(8x) \sec^3(8x) dx$

8. $\int \sec^8\left(\frac{1}{2}t\right) \tan^5\left(\frac{1}{2}t\right) dt$

9. $\int \sec^2(9z) \tan^3(9z) dz$

10. $\int_{\frac{3\pi}{4}}^{\pi} \sec^6(10t) \tan^4(10t) dt$

11. $\int \tan^{12}(2w) \sec^6(2w) dw$

12. $\int \cot^2(3x) \csc^6(3x) dx$

13. $\int_{\frac{\pi}{3}}^{\frac{2\pi}{3}} \csc^3\left(\frac{1}{4}w\right) \cot^3\left(\frac{1}{4}w\right) dw$

14. $\int \csc^4(6w) dw$

15. $\int \csc^{12}(x) \cot^5(x) dx$

16. $\int \cot(x) dx$

17. $\int \cot^3(x) dx$

18. $\int \csc(x) dx$

19. $\int \csc^3(x) dx$

20. $\int_{-2}^4 \sin(8x) \cos(15x) dx$

21. $\int \cos(2x) \cos(24x) dx$

22. $\int \sin(13z) \sin(9z) dz$

23. $\int \frac{\cos^5(2t)}{\sin^3(2t)} dt$

24. $\int \frac{\sin^3(2-x)}{\cos^2(2-x)} dx$

25. $\int \frac{\sec^6(\frac{1}{2}z)}{\tan^8(\frac{1}{2}z)} dz$

26. $\int \frac{\tan^5(x)}{\sec^2(x)} dx$

27. $\int \frac{1 + 9\cos^5(8w)}{\sin^2(8w)} dw$

28. $\int (3 + 7\cos^3(x)) \sin^2(x) dx$

29. $\int \sin^3(9y) \sec^2(9y) dy$

30. $\int \tan^5(z) \cos^5(z) dz$

31. $\int [\tan(2t) - \sin^3(2t)] \sec^3(2t) dt$

7.3 Trig Substitutions

For problems 1 - 15 use a trig substitution to eliminate the root.

1. $\sqrt{64t^2 + 1}$

2. $\sqrt{4z^2 - 49}$

3. $\sqrt{7 - w^2}$

4. $(16 - 81x^2)^{\frac{7}{2}}$

5. $\sqrt{6 + 9y^2}$

6. $(1 - 8z^2)^{\frac{3}{2}}$

7. $\sqrt{9 - 16(3x - 1)^2}$

8. $(11 + (t^2 + 1)^2)^{\frac{5}{2}}$

9. $\sqrt{144(z + 8)^2 - 3}$

10. $\sqrt{4x^2 - 24x + 43}$

11. $(2z^2 - 24z + 36)^{\frac{11}{2}}$

12. $\sqrt{-4 - 10t - 5t^2}$

13. $\sqrt{9\sin^2(4t) - 1}$

14. $\sqrt{36 - 9e^{3z}}$

15. $\sqrt{x + 16}$

For problems 16 - 32 use a trig substitution to evaluate the given integral.

16. $\int 3x^5 \sqrt{16 - x^2} dx$

17. $\int t^3 (25 + 81t^2)^{\frac{5}{2}} dt$

18. $\int_0^{\frac{1}{4}} \frac{w^3}{\sqrt{1 - 9w^2}} dw$

19. $\int \frac{z^5}{(9z^2 - 25)^{\frac{3}{2}}} dz$
20. $\int_{-3}^{-1} y^3 \sqrt{49y^2 - 4} dy$
21. $\int_1^5 \frac{5}{x^2 \sqrt{x^2 + 4}} dx$
22. $\int \frac{\sqrt{3 - 4t^2}}{t^2} dt$
23. $\int \frac{w^5}{\sqrt{8w^2 + 1}} dw$
24. $\int \frac{\sqrt{x^2 - 15}}{x^3} dx$
25. $\int \frac{2}{(x - 3)^6 \sqrt{-x^2 + 6x - 5}} dx$
26. $\int \frac{1}{(z + 1)^2 (2z^2 + 4z - 34)^{\frac{3}{2}}} dz$
27. $\int \frac{\sqrt{4y^2 - 16y + 19}}{(y - 2)^6} dy$
28. $\int_9^{12} \frac{(t - 4)^3}{\sqrt{t^2 - 8t + 7}} dt$
29. $\int_0^6 \sqrt{5x^2 + 10x + 6} dx$
30. $\int x^7 \sqrt{9 - x^4} dx$
31. $\int \frac{e^{12t}}{\sqrt{4e^{6t} - 1}} dt$
32. $\int \sin(z) \cos^3(z) \sqrt{16 + \cos^2(z)} dz$

7.4 Partial Fractions

Evaluate each of the following integrals.

1.
$$\int \frac{9}{z^2 - 12z} dz$$

2.
$$\int \frac{7x}{x^2 + 14x + 40} dx$$

3.
$$\int_0^4 \frac{8y - 1}{2y^2 - 15y - 8} dy$$

4.
$$\int \frac{9 - w^2}{(w + 1)(3w - 5)(w + 4)} dw$$

5.
$$\int_1^8 \frac{12}{z^3 - 2z^2 - 63z} dz$$

6.
$$\int \frac{7x + 2x^2}{(x - 4)(2x + 3)(2x + 1)} dx$$

7.
$$\int \frac{4x + 10}{(x - 2)(x - 1)^2} dx$$

8.
$$\int_1^2 \frac{24}{t^4 - 6t^3} dt$$

9.
$$\int \frac{10z + 2}{(z + 1)^2(z - 3)^2} dz$$

10.
$$\int \frac{8w + w^2}{(w - 7)(w^2 + 16)} dw$$

11.
$$\int \frac{6y - 7}{(2y + 1)(4y^2 + 1)} dy$$

12.
$$\int \frac{8t^3 - 5t^2 + 72t - 10}{(t^2 + 2)(t^2 + 9)} dt$$

13.
$$\int \frac{16w^3 + 6w^2 + 12w + 21}{(w^2 + 9)(4w^2 + 3)} dw$$

14.
$$\int \frac{x^4 + 5x^3 + 20x + 16}{x(x^2 + 4)^2} dx$$

15.
$$\int \frac{6 - z^2}{2z^2 + z - 21} dz$$

16.
$$\int \frac{4x^3 - x}{x^2 - x - 30} dx$$

17.
$$\int \frac{8 - t^3}{(t - 3)(t + 1)^2} dt$$

18.
$$\int \frac{x^6 - 6x^5 + 3x^4 - 10x^3 - 9x^2 + 12x - 27}{x^4 + 3x^2} dx$$

7.5 Integrals Involving Roots

Evaluate each of the following integrals.

1. $\int \frac{5}{4 - \sqrt{3 - z}} dz$

2. $\int \frac{1}{x + 4\sqrt{x - 3}} dx$

3. $\int \frac{4}{t - \sqrt{t + 7} + 1} dt$

4. $\int \frac{z}{2z + 3\sqrt{2z + 1} - 9} dz$

5. $\int \frac{w}{w - 2\sqrt{6 - 3w} - 5} dw$

6. $\int \cos(\sqrt{x}) dx$

7.6 Integrals Involving Quadratics

Evaluate each of the following integrals.

1. $\int \frac{x + 1}{x^2 + 10x + 18} dx$

2. $\int \frac{15}{3y^2 - 4y + 4} dy$

3. $\int \frac{12 - 9z}{1 - 4z - 4z^2} dz$

4. $\int \frac{3 - 7t}{(t^2 + 12t + 40)^2} dt$

5. $\int \frac{11w + 4}{(3 + 6w - w^2)^2} dw$

6. $\int \frac{3}{(2x^2 + 10x + 4)^{\frac{7}{2}}} dx$

7.7 Integration Strategy

Problems have not yet been written for this section.

I was finding it very difficult to come up with a good mix of new problems and decided my time was better spent writing problems for later sections rather than trying to come up with a sufficient number of problems for what is essentially a review section. I intend to come back at a later date when I have more time to devote to this section and add problems then.

7.8 Improper Integrals

Determine if each of the following integrals converge or diverge. If the integral converges determine its value.

1.
$$\int_4^{\infty} 2 - 4x + 6x^2 dx$$

2.
$$\int_0^5 \frac{1}{4w - 20} dw$$

3.
$$\int_{-1}^2 \frac{3}{\sqrt[6]{4 - 2z}} dz$$

4.
$$\int_{-\infty}^0 x e^{2+3x} dx$$

5.
$$\int_0^{\infty} x e^{2+3x} dx$$

6.
$$\int_2^{\infty} \frac{1}{x^2 + 1} dx$$

7.
$$\int_0^3 \frac{1}{z^2 - 4z} dz$$

8.
$$\int_{-\infty}^1 \frac{x}{x^2 + 1} dx$$

9.
$$\int_{-1}^2 \frac{1}{y^2 - 2y - 3} dy$$

10.
$$\int_{-\infty}^0 \cos(w) dw$$

11.
$$\int_{10}^{\infty} \frac{1}{(5 - 2z)^2} dz$$

12.
$$\int_{-\infty}^{\infty} \frac{z^3}{z^4 + 1} dz$$

13.
$$\int_1^4 \frac{1}{2y - 6} dy$$

14.
$$\int_1^5 \frac{1}{\sqrt[3]{w - 2}} dw$$

15.
$$\int_{-2}^1 \frac{e^{\frac{1}{x}}}{x^2} dx$$

16.
$$\int_{-\infty}^{\infty} x^2 e^{x^3} dx$$

17.
$$\int_{-\infty}^{\infty} \frac{y}{(y^2 + 1)^3} dy$$

18.
$$\int_0^3 \frac{w^3}{\sqrt{9 - w^2}} dw$$

19.
$$\int_{-3}^1 \frac{1}{w^2 + 2w} dw$$

20.
$$\int_0^{\infty} \frac{e^{\frac{1}{x}}}{x^2} dx$$

21.
$$\int_0^{\infty} \frac{1}{z[\ln(z)]^2} dz$$

22.
$$\int_0^{\infty} \frac{1}{w - 1} dw$$

7.9 Comparison Test for Improper Integrals

Use the Comparison Test to determine if the following integrals converge or diverge.

1.
$$\int_4^{\infty} \frac{1}{\sqrt[5]{z-2}} dz$$

2.
$$\int_0^{\infty} \frac{w}{\sqrt{w^6+2}} dw$$

3.
$$\int_2^{\infty} \frac{1}{(2w+3)^4} dw$$

4.
$$\int_{12}^{\infty} \frac{y^2 - 4y + 2}{y-7} dy$$

5.
$$\int_2^{\infty} \frac{1}{\ln(x)} dx$$

Hint : Sketch the graph of $y = x$ and $y = \ln(x)$ on the same axis system.

6.
$$\int_2^{\infty} \frac{\sqrt{z} - 4\sin^2(z)}{z^3} dz$$

7.
$$\int_{20}^{\infty} \frac{\sqrt[3]{2x} + \sin^2(x)}{\sqrt{x} - \cos^2(x)} dx$$

8.
$$\int_0^{\infty} \frac{ze^{-z}}{z^3+1} dz$$

7.10 Approximating Definite Integrals

For each of the following integrals use the given value of n to approximate the value of the definite integral using

(a) the Midpoint Rule,

(b) the Trapezoid Rule, and

(c) Simpson's Rule.

Use at least 6 decimal places of accuracy for your work.

1. $\int_{-2}^4 \sin(x^2 + 2) dx$ using $n = 6$

2. $\int_0^4 \sqrt[3]{x^4 + 6} dx$ using $n = 6$

3. $\int_1^5 e^{\cos(x)} dx$ using $n = 8$

4. $\int_3^5 \frac{1}{1 - \ln(x)} dx$ using $n = 6$

5. $\int_{-3}^1 \sin(x) \cos(x^2) dx$ using $n = 8$

8 More Applications of Integrals

It is now time to take a look at some more applications of integrals. As noted the last time we looked at applications of integrals many, although, not all of these new applications in this chapter have a fairly high chance of needing some of the integration techniques from the last chapter.

The first application, Arc Length can be kept to only u -substitutions at the worst, but most of those problems tend to be very simple. Once we start moving into more complicated problems arc length problems tend to involve trig substitutions.

The next application, Surface Area tends to be u -substitutions but the notation used here is also used in the Arc Length section and so the surface area section is also here because of the shared notation.

Center of Mass and Probability are applications that will, in almost every case, involve integration by parts. In addition, the Probability section has the potential for improper integrals to show up.

The other application we'll be looking at in this chapter, Hydrostatic Pressure and Force, will typically involve fairly simple integrals that could have been done in the earlier chapter. The reason the topic is here is because we have to derive up the integral using the definition of the definite integral in every problem. In addition, more complicated problems could lead to much more complicated integrals. The integrals in this section are kept simple mostly to keep the derivation work simpler.

If you are looking for some practice problems (with solutions available) please check out the [Practice Problems](#). There you will find a set of problems that should give you quite a bit practice.

8.1 Arc Length

1. Set up, but do not evaluate, an integral for the length of $y = 14 - 9x$, $-22 \leq y \leq 31$ using,

(a) $ds = \sqrt{1 + \left[\frac{dy}{dx}\right]^2} dx$

(b) $ds = \sqrt{1 + \left[\frac{dx}{dy}\right]^2} dy$

2. Set up, but do not evaluate, an integral for the length of $x = e^{2y}$, $-1 \leq y \leq 0$ using,

(a) $ds = \sqrt{1 + \left[\frac{dy}{dx}\right]^2} dx$

(b) $ds = \sqrt{1 + \left[\frac{dx}{dy}\right]^2} dy$

3. Set up, but do not evaluate, an integral for the length of $y = \tan(2x)$, $0 \leq x \leq \frac{\pi}{3}$ using,

(a) $ds = \sqrt{1 + \left[\frac{dy}{dx}\right]^2} dx$

(b) $ds = \sqrt{1 + \left[\frac{dx}{dy}\right]^2} dy$

4. Set up, but do not evaluate, an integral for the length of $\frac{x^2}{16} + 9y^2 = 1$.

5. For $x = 6y + 1$, $-2 \leq y \leq 8$

(a) Use an integral to find the length of the curve.

(b) Verify your answer from part (a) geometrically.

6. Determine the length of $y = \frac{4}{3}x + 2$, $0 \leq x \leq 9$.

7. Determine the length of $y = (8x + 3)^{\frac{3}{2}}$, $11^{\frac{3}{2}} \leq y \leq 27^{\frac{3}{2}}$.

8. Determine the length of $x = (10 - 2y)^{\frac{3}{2}}$, $-1 \leq y \leq 2$.

9. Determine the length of $x = 2 + (y - 1)^2$, $2 \leq y \leq 5$.

10. Determine the length of $y = (3x + 2)^2$, $1 \leq x \leq 4$.

8.2 Surface Area

1. Set up, but do not evaluate, an integral for the surface area of the object obtained by rotating $y = 7x + 2$, $-5 \leq y \leq 0$ about the x -axis using,

$$(a) \quad ds = \sqrt{1 + \left[\frac{dy}{dx}\right]^2} dx$$

$$(b) \quad ds = \sqrt{1 + \left[\frac{dx}{dy}\right]^2} dy$$

2. Set up, but do not evaluate, an integral for the surface area of the object obtained by rotating $y = 1 + 2x^5$, $0 \leq x \leq 1$ about the x -axis using,

$$(a) \quad ds = \sqrt{1 + \left[\frac{dy}{dx}\right]^2} dx$$

$$(b) \quad ds = \sqrt{1 + \left[\frac{dx}{dy}\right]^2} dy$$

3. Set up, but do not evaluate, an integral for the surface area of the object obtained by rotating $x = e^{2y}$, $-1 \leq y \leq 0$ about the y -axis using,

$$(a) \quad ds = \sqrt{1 + \left[\frac{dy}{dx}\right]^2} dx$$

$$(b) \quad ds = \sqrt{1 + \left[\frac{dx}{dy}\right]^2} dy$$

4. Set up, but do not evaluate, an integral for the surface area of the object obtained by rotating $y = \cos\left(\frac{1}{2}x\right)$, $0 \leq x \leq \pi$ about

(a) the x -axis

(b) the y -axis

5. Set up, but do not evaluate, an integral for the surface area of the object obtained by rotating $x = \sqrt{3+7y}$, $0 \leq y \leq 1$ about

(a) the x -axis

(b) the y -axis

6. Find the surface area of the object obtained by rotating $y = \frac{1}{4}\sqrt{6x+2}$, $\frac{\sqrt{2}}{2} \leq y \leq \frac{\sqrt{5}}{2}$ about the x -axis.

7. Find the surface area of the object obtained by rotating $y = 4 - x$, $1 \leq x \leq 6$ about the y -axis.
8. Find the surface area of the object obtained by rotating $x = 2y + 5$, $-1 \leq x \leq 2$ about the y -axis.
9. Find the surface area of the object obtained by rotating $x = 1 - y^2$, $0 \leq y \leq 3$ about the x -axis.
10. Find the surface area of the object obtained by rotating $x = e^{2y}$, $-1 \leq y \leq 0$ about the y -axis.
11. Find for the surface area of the object obtained by rotating $y = \cos\left(\frac{1}{2}x\right)$, $0 \leq x \leq \pi$ about the x -axis.

8.3 Center Of Mass

Find the center of mass for each of the following regions.

1. The region bounded by $y = x^3$, $x = -2$ and the x -axis.
2. The triangle with vertices $(-2, -2)$, $(4, -2)$ and $(4, 4)$.
3. The region bounded by $y = (x - 2)^2$ and $y = 4$.
4. The region bounded by $y = \cos(x)$ and the x -axis between $-\frac{\pi}{2} \leq x \leq \frac{\pi}{2}$.
5. The region bounded by $y = x^2$ and $y = 6 - x$.
6. The region bounded by $y = e^{2x}$ and the x -axis between $-1 \leq x \leq 1$.
7. The region bounded by $y = e^{2x}$ and $y = -\cos(\pi x)$ between $-\frac{1}{2} \leq x \leq \frac{1}{2}$.

8.4 Hydrostatic Pressure and Force

Find the hydrostatic force on the following plates submerged in water as shown in each image. In each case consider the top of the blue “box” to be the surface of the water in which the plate is submerged. Note as well that the dimensions in many of the images will not be perfectly to scale in order to better fit the plate in the image. The lengths given in each image are in meters.

1.

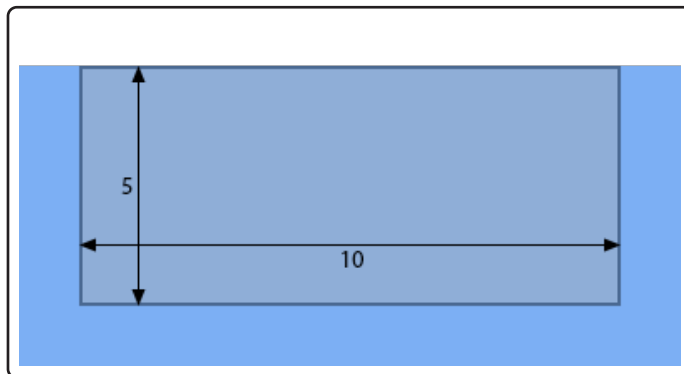

2.

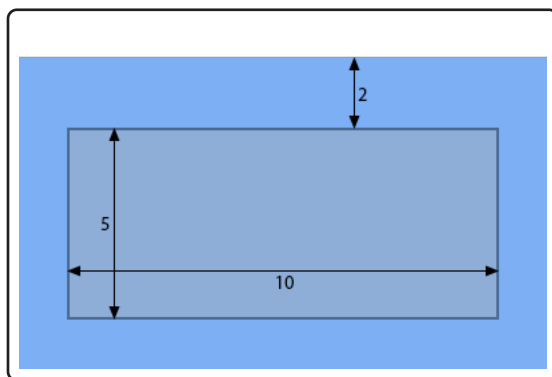

3.

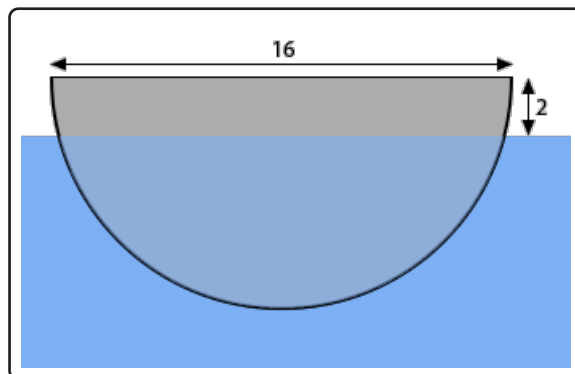

4.

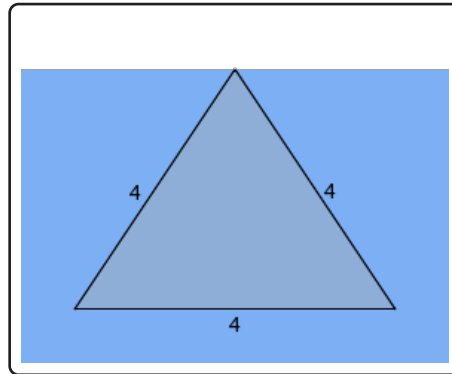

5.

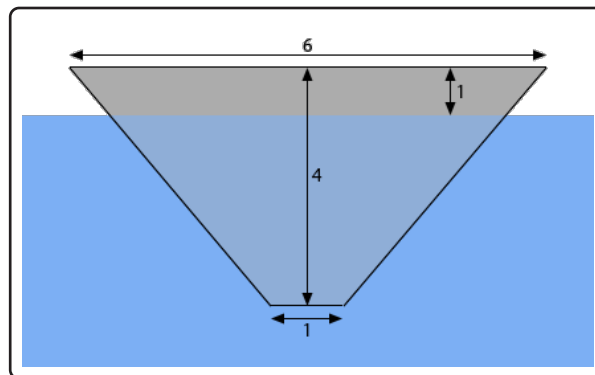

6.

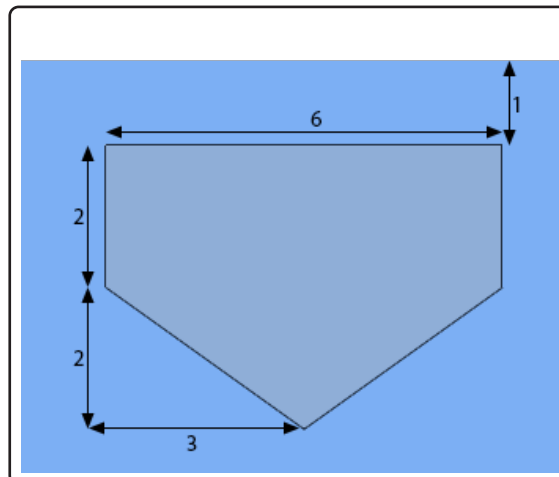

7.

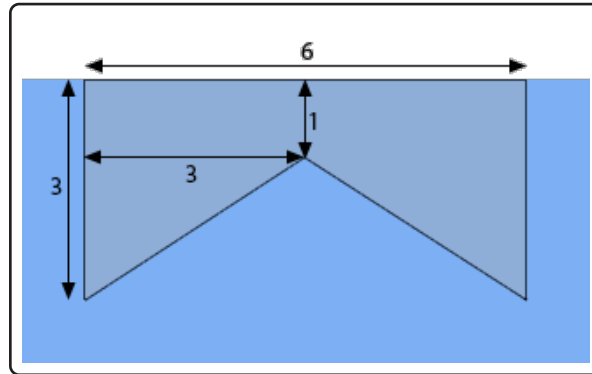

8.5 Probability

1. Let,

$$f(x) = \begin{cases} \frac{3}{4}(2x - x^2) & \text{if } 0 \leq x \leq 2 \\ 0 & \text{otherwise} \end{cases}$$

(a) Show that $f(x)$ is a probability density function.(b) Find $P(X \leq 0.25)$.(c) Find $P(X \geq 1.4)$.(d) Find $P(0.1 \leq X \leq 1.2)$.(e) Determine the mean value of X .

2. Let,

$$f(x) = \begin{cases} \frac{4}{\ln(3)(4x + x^2)} & \text{if } 1 \leq x \leq 6 \\ 0 & \text{otherwise} \end{cases}$$

(a) Show that $f(x)$ is a probability density function.(b) Find $P(X \leq 1)$.(c) Find $P(X \geq 5)$.(d) Find $P(1 \leq X \leq 5)$.(e) Determine the mean value of X .

3. Let,

$$f(x) = \begin{cases} \frac{1}{10} \left(1 + \sin \left(\pi x - \frac{\pi}{2} \right) \right) & \text{if } 0 \leq x \leq 10 \\ 0 & \text{otherwise} \end{cases}$$

(a) Show that $f(x)$ is a probability density function.(b) Find $P(X \leq 3)$.(c) Find $P(X \geq 5)$.(d) Find $P(2.5 \leq X \leq 7)$.(e) Determine the mean value of X .

4. The probability density function of the life span of a battery is given by the function below, where t is in years.

$$f(t) = \begin{cases} 1.25e^{-1.25t} & \text{if } t \geq 0 \\ 0 & \text{if } t < 0 \end{cases}$$

- (a) Verify that $f(t)$ is a probability density function.
- (b) What is the probability that a battery will have a life span less than 10 months?
- (c) What is the probability that a battery will have a life span more than 2 years?
- (d) What is the probability that a battery will have a life span between 1.5 and 4 years?
- (e) Determine the mean value of the life span of the batteries.
5. The probability density function of the successful outcome from some experiment is given by the function below, where t is in minutes.

$$f(t) = \begin{cases} \frac{1}{9}t e^{-\frac{t}{3}} & \text{if } t \geq 0 \\ 0 & \text{if } t < 0 \end{cases}$$

- (a) Verify that $f(t)$ is a probability density function.
- (b) What is the probability of a successful outcome happening in less than 12 minutes?
- (c) What is the probability of a successful outcome happening after 25 minutes?
- (d) What is the probability of a successful outcome happening between 10 and 75 minutes?
- (e) What is the mean time of a successful outcome from the experiment?
6. Determine the value of c for which the function below will be a probability density function.

$$f(x) = \begin{cases} c(12x^4 - x^5) & \text{if } 0 \leq x \leq 12 \\ 0 & \text{otherwise} \end{cases}$$

7. Use the function below for this problem and assume $a > 0$.

$$f(x) = \begin{cases} c e^{-\frac{1}{a}x} & x \geq 0 \\ 0 & x < 0 \end{cases}$$

- (a) Determine the value of c for which this function will be a probability density function.
- (b) Using the value of c found in the first part determine the mean value of the probability density function.

9 Parametric Equations and Polar Coordinates

We are now going to take a look at a couple of topics that are completely different from anything we've seen to this point. That does not mean, however, that we can just forget everything that we've seen to this point. As we will see before too long we will still need to be able to do a large part of the material (both Calculus I and Calculus II material) that we've looked at to this point.

The first major topic that we'll look at in this chapter will be that of Parametric Equations. Parametric Equations will allow us to work with and perform Calculus operations on equations that cannot be solved into the form $y = f(x)$ or $x = h(y)$ (assuming we are using x and y as our variables). Also, as we'll see we can write some equations that can be solved for y or x as a set of easier to work with parametric equations.

Once we've got an idea of what parametric equations are and how to sketch graphs of them we will revisit some of the Calculus topics we've looked at to this point. We'll take a look at how to use only parametric equations to get the equation of tangent lines, where the graph is increasing/decreasing and the concavity of the graph. In addition, we'll revisit the idea of using a definite integral to find the area between the graph of a set of parametric equation and the x -axis. We will close out the Calculus topics by discussing arc length and surface area for a set of parametric equations.

We will then move into the other major topic of this chapter, namely Polar Coordinates. Once we've defined polar coordinates and gotten comfortable with them we will, again, revisit the same Calculus topics we looked at in terms of parametric equations.

On the surface it will appear that polar coordinates has nothing in common with parametric equations. We will see however that several topics in Polar Coordinates can be easily done, in some way, if we first set them up in terms of parametric equations.

In addition, we should point out that the purpose of the topics in this chapter is in preparation for multi-variable Calculus (*i.e.* the material that is usually taught in Calculus III). As we will see when we get to that point there are a lot of topics that involve and/or require parametric equations. In addition, polar coordinates will pop up every so often so keep that in mind as we go through this stuff. It is easy sometimes to get the idea that the topics in this chapter don't have a lot of use but once we hit multi-variable Calculus they will start to pop up with some regularity.

If you are looking for some practice problems (with solutions available) please check out the [Practice Problems](#). There you will find a set of problems that should give you quite a bit practice.

9.1 Parametric Equations and Curves

For problems 1 - 9 eliminate the parameter for the given set of parametric equations, sketch the graph of the parametric curve and give any limits that might exist on x and y .

1. $x = 2 + t$ $y = t^2 - 4t + 7$

2. $x = 2 + t$ $y = t^2 - 4t + 7$ $-3 \leq t \leq 1$

3. $x = 1 - t^2$ $y = 3 + 2t$

4. $x = 1 - t^2$ $y = 3 + 2t$ $-2 \leq t \leq 3$

5. $x = \frac{1}{2}\sqrt{t}$ $y = t - \sqrt{t} - 6$ $t \geq 0$

6. $x = \frac{1}{2}\sqrt{t}$ $y = t - \sqrt{t} - 6$ $8 \leq t \leq 20$

7. $x = -6 \cos(4t)$ $y = 2 \sin(4t)$ $-\frac{\pi}{4} \leq t \leq \frac{\pi}{8}$

8. $x = 1 - 3 \sin\left(\frac{1}{2}t\right)$ $y = 4 \cos\left(\frac{1}{2}t\right)$

9. $x = 6 - 7e^{-2t}$ $y = 4 + 3e^{-2t}$

10. Answer each of the questions about the following set of parametric equations

$$x = 3 \cos(at) \quad y = 3 \sin(at) \quad 0 \leq t \leq 2\pi$$

(a) Sketch the graph of the parametric curve for $a = 1$.

(b) Sketch the graph of the parametric curve for $a = 6$.

(c) Sketch the graph of the parametric curve for $a = \frac{1}{5}$.

(d) In general, for $a > 0$, how does the value of a affect the graph of the parametric curve?

For problems 11 - 21 the path of a particle is given by the set of parametric equations. Completely describe the path of the particle. To completely describe the path of the particle you will need to provide the following information.

(i) A sketch of the parametric curve (including direction of motion) based on the equation you get by eliminating the parameter.

(ii) Limits on x and y .

(iii) A range of t 's for a single trace of the parametric curve.

(iv) The number of traces of the curve the particle makes if an overall range of t 's is provided in the problem.

$$11. x = 6 \cos\left(\frac{1}{3}t\right) \quad y = 2 + \sin\left(\frac{1}{3}t\right) \quad 0 \leq t \leq 75\pi$$

$$12. x = 7 - 3 \sin(2t) \quad y = 4 + 2 \cos(2t)$$

$$13. x = 6 \cos^2(3t) \quad y = 2 - 3 \sin^2(3t) \quad -\frac{5}{6}\pi \leq t \leq 3\pi$$

$$14. x = \sqrt{2 + \cos^2\left(\frac{7}{4}t\right)} \quad y = \frac{1}{3} \sin\left(\frac{7}{4}t\right)$$

$$15. x = 6 - \sin^3(4t) \quad y = 2 \sin(4t) \quad -127\pi \leq t \leq 201\pi$$

$$16. x = 3 + \cos\left(\frac{1}{6}t\right) \quad y = 4 + \cos^2\left(\frac{1}{6}t\right) \quad -90\pi \leq t \leq 216\pi$$

$$17. x = e^{-4t} \quad y = 2e^{12t}$$

$$18. x = 1 + e^{3t} \quad y = e^{6t} \quad -1 \leq t \leq 6$$

$$19. x = 1 - \ln(t) \quad y = [\ln(t)]^2 \quad t > 0$$

$$20. x = \cos\left(\frac{1}{2}t\right) \quad y = \sec\left(\frac{1}{2}t\right) \quad -\pi < t < \pi$$

$$21. x = \sin(2t) \quad y = \sin^2(2t) - 4 \sin(2t) \quad -\frac{91}{4}\pi \leq t \leq \frac{17}{4}\pi$$

For problems 22 - 27 write down a set of parametric equations for the given equation that meets the given extra conditions (if any).

$$22. x = \sin(3 - y^2) + \cos^2(y)$$

$$23. y = \frac{6 \cos(x) - 8}{x^2 + 9x}$$

24. $x^2 + y^2 = 100$ and the parametric curve resulting from the parametric equations should be at $(0, 10)$ when $t = 0$ and the curve should have a clockwise rotation.
25. $x^2 + y^2 = 100$ and the parametric curve resulting from the parametric equations should be at $(0, 10)$ when $t = 0$ and the curve should have a counter clockwise rotation.
26. $\frac{x^2}{25} + y^2 = 1$ and the parametric curve resulting from the parametric equations should be at $(-5, 0)$ when $t = 0$ and the curve should have a counter clockwise rotation.
27. $\frac{x^2}{25} + y^2 = 1$ and the parametric curve resulting from the parametric equations should be at $(-5, 0)$ when $t = 0$ and the curve should have a clockwise rotation.
28. Eliminate the parameter for the following set of parametric equations and identify the resulting equation.

$$x = h + a \cos(\omega t) \qquad y = k + b \sin(\omega t)$$

9.2 Tangents with Parametric Equations

For problems 1 - 3 compute $\frac{dy}{dx}$ and $\frac{d^2y}{dx^2}$ for the given set of parametric equations.

1. $x = 7t^2 - 9t$ $y = t^6 + 2t^2$

2. $x = \tan(2t) - 12$ $y = 3 \sin(2t) + \sec(2t) + 4t$

3. $x = \ln(3t^2) + 8t$ $y = \ln(t^4) - 6 \ln(t^2)$

For problems 4 - 7 find the equation of the tangent line(s) to the given set of parametric equations at the given point.

4. $x = t^3 + \cos(\pi t)$ $y = 4t + \sin(2t + 6)$ at $t = -3$

5. $x = t^2 + 2t - 1$ $y = t^3 + 7t^2 + 8t$ at $t = 1$

6. $x = 6 - e^{t^3-9t}$ $y = t^3 + 3t^2 - 18t + 2$ at $(5, 2)$

7. $x = t^2 + 5t - 6$ $y = t^2 + 2t - 8$ at $(-6, 7)$

For problems 8 and 9 find the values of t that will have horizontal or vertical tangent lines for the given set of parametric equations.

8. $x = t^3 - 5t^2 + t + 1$ $y = t^4 + 8t^3 + 3t^2$

9. $x = 7t^2 + e^{2-t^2}$ $y = 10 \sin\left(\frac{1}{2}t\right) - 1$

9.3 Area with Parametric Equations

For problems 1 - 3 determine the area of the region below the parametric curve given by the set of parametric equations. For each problem you may assume that each curve traces out exactly once from right to left for the given range of t . For these problems you should only use the given parametric equations to determine the answer.

1. $x = t^2 + 5t - 1$ $y = 40 - t^2$ $-2 \leq t \leq 5$

2. $x = 3 \cos^2(t) - \sin^2(t)$ $y = 6 + \cos(t)$ $-\frac{\pi}{2} \leq t \leq 0$

3. $x = e^{\frac{1}{4}t} - 2$ $y = 4 + e^{\frac{1}{4}t} - e^{\frac{1}{2}t}$ $-6 \leq t \leq 1$

9.4 Arc Length with Parametric Equations

For all the problems in this section you should only use the given parametric equations to determine the answer.

For problems 1 - 5 determine the length of the parametric curve given by the set of parametric equations. For these problems you may assume that the curve traces out exactly once for the given range of t 's.

1. $x = 3 + 9t$ $y = 10 - 15t$ $-5 \leq t \leq 8$

2. $x = 6(3 + t)^{\frac{3}{2}}$ $y = -3t^{\frac{3}{2}}$ $-2 \leq t \leq 1$

3. $x = 4t^2 - 3$ $y = 3t$ $0 \leq t \leq 5$

4. $x = 3 + t$ $y = 6 + (t - 1)^2$ $1 \leq t \leq 3$

5. $x = t^2 - 1$ $y = t^4 + 5$ $0 \leq t \leq 1$

For problems 6 and 7 a particle travels along a path defined by the following set of parametric equations. Determine the total distance the particle travels and compare this to the length of the parametric curve itself.

6. $x = 6 \cos^2(3t)$ $y = 2 - 3 \sin^2(3t)$ $-\frac{5}{6}\pi \leq t \leq 3\pi$

7. $x = 3 + \cos\left(\frac{1}{6}t\right)$ $y = 4 + \cos^2\left(\frac{1}{6}t\right)$ $-90\pi \leq t \leq 216\pi$

For problems 8 - 10 set up, but do not evaluate, an integral that gives the length of the parametric curve given by the set of parametric equations. For these problems you may assume that the curve traces out exactly once for the given range of t 's.

8. $x = t \cos(2t)$ $y = \sin(3t)$ $2 \leq t \leq 3$

9. $x = 1 - \sin(1 + \sqrt{t})$ $y = \sin(e^{-t})$ $1 \leq t \leq 4$

10. $x = \ln(t + 2)$ $y = \frac{1}{t + 7}$ $-1 \leq t \leq 2$

9.5 Surface Area with Parametric Equations

For all the problems in this section you should only use the given parametric equations to determine the answer.

For problems 1 - 4 determine the surface area of the object obtained by rotating the parametric curve about the given axis. For these problems you may assume that the curve traces out exactly once for the given range of t 's.

1. Rotate $x = t^2 - 3$ $y = 2 + t^2$ $0 \leq t \leq 5$ about the x -axis.
2. Rotate $x = -8t$ $y = 6 + t^2$ $-3 \leq t \leq 0$ about the y -axis.
3. Rotate $x = t^2$ $y = t^4 - 2$ $0 \leq t \leq 2$ about the y -axis.
4. Rotate $x = 2 + t$ $y = 4e^{-\frac{1}{2}t}$ $-1 \leq t \leq 2$ about the x -axis.

For problems 5 - 7 set up, but do not evaluate, an integral that gives the surface area of the object obtained by rotating the parametric curve about the given axis. For these problems you may assume that the curve traces out exactly once for the given range of t 's.

5. Rotate $x = 2 + e^{\cos(t)}$ $y = 1 + t^2$ $-2 \leq t \leq 0$ about the x -axis.
6. Rotate $x = \cos^2(t)$ $y = 2 \cos(2t) - \sin(t)$ $0 \leq t \leq 1$ about the y -axis.
7. Rotate $x = t^2$ $y = \ln(3 + e^{-t})$ $0 \leq t \leq 2$ about the x -axis.

9.6 Polar Coordinates

- For the point with polar coordinates $\left(-9, \frac{3\pi}{7}\right)$ determine three different sets of coordinates for the same point all of which have angles different from $\frac{3\pi}{7}$ and are in the range $-2\pi \leq \theta \leq 2\pi$.
- For the point with polar coordinates $\left(7, -\frac{2\pi}{3}\right)$ determine three different sets of coordinates for the same point all of which have angles different from $-\frac{2\pi}{3}$ and are in the range $-2\pi \leq \theta \leq 2\pi$.
- The polar coordinates of a point are $(14, 2.48)$. Determine the Cartesian coordinates for the point.
- The polar coordinates of a point are $\left(-\frac{3}{10}, -5.29\right)$. Determine the Cartesian coordinates for the point.
- The Cartesian coordinate of a point are $(-3, 5)$. Determine a set of polar coordinates for the point.
- The Cartesian coordinate of a point are $(4, -7)$. Determine a set of polar coordinates for the point.
- The Cartesian coordinate of a point are $(-3, -12)$. Determine a set of polar coordinates for the point.

For problems 8 and 9 convert the given equation into an equation in terms of polar coordinates.

8. $7x^2y + 8y = 3 - 6x^2 - 6y^2$

9. $\frac{7y}{x^2 + y^2 - 8x} = 9 + y^2$

For problems 10 - 13 convert the given equation into an equation in terms of Cartesian coordinates.

10. $r - \frac{8 \sin(\theta)}{r} = 2 \cos(\theta)$

11. $r^3 \csc(\theta) = 5 \cos(\theta) - 6$

12. $8 - r = r^2 \sin(2\theta)$

13. $r = 2a \cos(\theta) + 2b \sin(\theta)$

For problems 14 - 27 sketch the graph of the given polar equation.

14. $-7 = r \sin(\theta)$

15. $\theta = \frac{5\pi}{7}$

16. $\theta = -\frac{9\pi}{5}$

17. $r \cos(\theta) = 4$

18. $r = 6 \sin(\theta)$

19. $r = 100$

20. $r = 24 \cos(\theta)$

21. $r = -15 \sin(\theta)$

22. $r = 4 + 12 \cos(\theta)$

23. $r = 7 - 7 \sin(\theta)$

24. $r = 1 + 3 \sin(\theta)$

25. $r = 5 - 4 \cos(\theta)$

26. $r = 8 + 3 \sin(\theta)$

27. $r = 1 - \cos(\theta)$

9.7 Tangents with Polar Coordinates

1. Find the tangent line to $r = \theta \sin(3\theta)$ at $\theta = \frac{\pi}{2}$.
2. Find the tangent line to $r = \cos(2\theta) - \sin(\theta)$ at $\theta = -\frac{\pi}{4}$.
3. Find the tangent line to $r = \cos(\theta^2 - \theta)$ at $\theta = \pi$.

9.8 Area with Polar Coordinates

1. Find the area inside the inner loop of $r = 3 + 10 \sin(\theta)$.
2. Find the area inside the inner loop of $r = 5 + 12 \cos(\theta)$.
3. Find the area inside the graph of $r = 8 + \cos(\theta)$ and to the right of the y -axis.
4. Find the area inside the graph of $r = 5 - 4 \sin(\theta)$ and the below the x -axis.
5. Find the area that is inside $r = 4$ and outside $r = 4 - 2 \sin(\theta)$.
6. Find the area that is inside $r = 7 - 3 \cos(\theta)$ and outside $r = 4$.
7. Find the area that is inside $r = 6 + 6 \cos(\theta)$ and outside $r = 4 - 3 \cos(\theta)$.
8. Find the area that is inside $r = 4 + 2 \sin(\theta)$ and outside $r = 5 - \sin(\theta)$.
9. Find the area that is inside $r = 5 - \sin(\theta)$ and outside $r = 4 + 2 \sin(\theta)$.
10. Find the area that is inside both $r = 6 - 4 \sin(\theta)$ and $r = 5$.
11. Find the area that is inside both $r = 3 + 2 \cos(\theta)$ and $r = 3 - \cos(\theta)$.

9.9 Arc Length with Polar Coordinates

For problems 1 - 3 determine the length of the given polar curve. For these problems you may assume that the curve traces out exactly once for the given range of θ .

1. $r = \frac{1}{\cos(\theta)}, 0 \leq \theta \leq \frac{\pi}{3}$

2. $r = \theta^2, 0 \leq \theta \leq 3\pi$

3. $r = 6 \cos(\theta) - 3 \sin(\theta), 0 \leq \theta \leq \pi$

For problems 4 - 6 set up, but do not evaluate, an integral that gives the length of the given polar curve. For these problems you may assume that the curve traces out exactly once for the given range of θ .

4. $r = \sin(\theta^2), 0 \leq \theta \leq \pi$

5. $r = \cos(1 + \sin(\theta)), 0 \leq \theta \leq 2\pi$

6. $r = e^{-\frac{1}{4}\theta} \cos(\theta), 0 \leq \theta \leq 3\pi$

9.10 Surface Area with Polar Coordinates

For problems 1 - 4 set up, but do not evaluate, an integral that gives the surface area of the curve rotated about the given axis. For these problems you may assume that the curve traces out exactly once for the given range of θ .

1. $r = \cos\left(e^{-\frac{1}{4}\theta}\right)$, $0 \leq \theta \leq \frac{\pi}{2}$ rotated about the x -axis.

2. $r = \theta \sin(\theta)$, $0 \leq \theta \leq \frac{\pi}{2}$ rotated about the y -axis.

3. $r = \cos(\theta) \sin(2\theta)$, $0 \leq \theta \leq \frac{\pi}{6}$ rotated about the x -axis.

4. $r = \theta + \sin(\theta)$, $\frac{\pi}{2} \leq \theta \leq \pi$ rotated about the y -axis.

9.11 Arc Length and Surface Area Revisited

Problems have not yet been written for this section and probably won't be to be honest since this is just a summary section.

10 Series and Sequences

Once again, as with the last chapter, we are going to be looking at a completely different topic in this chapter. The only material from previous chapters that will be needed here will be the ability to compute limits at infinity (we'll do a fair amount of these), compute the rare derivatives and compute the occasional integral. The integrals will, generally, be fairly simple and needing u substitutions every once in a while although we will see the occasional integral requiring integration by parts or partial fractions. So, basically, the material in this chapter doesn't really rely all that much on previous material.

Series is one of those topics that many students don't find all that useful. To be honest, many students will never see series outside of their calculus class. However, series do play an important role in the field of ordinary differential equations and without series large portions of the field of partial differential equations would not be possible.

In other words, series is an important topic even if you won't ever see any of the applications. Most of the applications are beyond the scope of most Calculus courses and tend to occur in classes that many students don't take. So, as you go through this material keep in mind that these do have applications even if we won't really be covering many of them in this class.

The first topic we'll be looking at in this chapter is that of a sequence. We'll define just what we mean by a sequence and look at some basic topics and concepts that we'll need to work with them.

The other topic will be that of (infinite) series. In fact, we will spend the vast majority of this chapter deal with series. We can't, however, fully discuss series without understanding sequences and hence the reason for discussing sequences first. We will define just what an infinite series is and what it means for a series to converge or diverge. The majority of this chapter will then be spent discussing a variety of methods for testing whether or not a series will converge or diverge.

We'll close out the chapter with a discussion of power series and Taylor series as well as a couple of quick applications of series that we can easily discuss without needing any extra knowledge (as is needed for most applications of series).

If you are looking for some practice problems (with solutions available) please check out the [Practice Problems](#). There you will find a set of problems that should give you quite a bit practice.

10.1 Sequences

For problems 1 - 3 list the first 5 terms of the sequence.

1. $\left\{ (-1)^n e^{2n} \right\}_{n=1}^{\infty}$

2. $\left\{ \frac{6 - 8n}{n^2 + 9n} \right\}_{n=2}^{\infty}$

3. $\left\{ \frac{4}{(-2)^{n+1} + 3^n} \right\}_{n=1}^{\infty}$

For problems 4 - 10 determine if the given sequence converges or diverges. If it converges what is its limit?

4. $\left\{ \frac{5 + n^3}{2n^2 - 8n + 1} \right\}_{n=0}^{\infty}$

5. $\left\{ \frac{6n^4 + 9n^2}{9n^4 - 8n^2 + 7} \right\}_{n=11}^{\infty}$

6. $\left\{ \frac{(-1)^{n+7} (2 - 8n)}{n^2 + 9} \right\}_{n=2}^{\infty}$

7. $\left\{ \cos(n\pi) \right\}_{n=0}^{\infty}$

8. $\left\{ \frac{n + 1}{\ln(6n)} \right\}_{n=2}^{\infty}$

9. $\left\{ \cos\left(\frac{3}{n+1}\right) \right\}_{n=1}^{\infty}$

10. $\left\{ \ln(4n + 1) - \ln(2 + 7n) \right\}_{n=0}^{\infty}$

10.2 More on Sequences

For each of the following problems determine if the sequence is increasing, decreasing, not monotonic, bounded below, bounded above and/or bounded.

1. $\left\{ \frac{1}{n^3 + 1} \right\}_{n=1}^{\infty}$

2. $\left\{ e^{3n} \right\}_{n=0}^{\infty}$

3. $\left\{ (-3)^n \right\}_{n=0}^{\infty}$

4. $\{ \sin(n) \}_{n=4}^{\infty}$

5. $\left\{ \ln \left(\frac{1}{n} \right) \right\}_{n=2}^{\infty}$

6. $\left\{ \frac{3 - n}{1 - 3n} \right\}_{n=1}^{\infty}$

7. $\left\{ \frac{2n + 1}{4n + 3} \right\}_{n=0}^{\infty}$

8. $\left\{ (1 - n) e^n \right\}_{n=3}^{\infty}$

9. $\left\{ \frac{n^2 + 40}{n^2 + 3n + 1} \right\}_{n=1}^{\infty}$

10. $\left\{ \frac{5 + n}{100,000 + n^2} \right\}_{n=0}^{\infty}$

10.3 Series - Basics

For problems 1 - 4 perform an index shift so that the series starts at $n = 4$.

1.
$$\sum_{n=8}^{\infty} \frac{2+n}{5-n}$$

2.
$$\sum_{n=2}^{\infty} \frac{3^{n+2}}{1-4^{3n+1}}$$

3.
$$\sum_{n=0}^{\infty} (-2)^{2-n} e^{3n}$$

4.
$$\sum_{n=5}^{\infty} \frac{(-1)^{3+n} n^2}{n^2 - 2n + 1}$$

5. Strip out the first 4 terms from the series
$$\sum_{n=0}^{\infty} 3^n 6^{2-n}.$$

6. Strip out the first 2 terms from the series
$$\sum_{n=3}^{\infty} \frac{4}{n^2 + n + 1}.$$

7. Given that
$$\sum_{n=4}^{\infty} n 4^{-n} = 0.02257$$
 determine the value of
$$\sum_{n=1}^{\infty} n 4^{-n}.$$

8. Given that
$$\sum_{n=3}^{\infty} \frac{n+1}{n^3} = 0.47199$$
 determine the value of
$$\sum_{n=5}^{\infty} \frac{n+1}{n^3}.$$

10.4 Convergence & Divergence of Series

For problems 1 - 4 compute the first 3 terms in the sequence of partial sums for the given series.

$$1. \sum_{n=0}^{\infty} \frac{1}{1+3^n}$$

$$2. \sum_{n=1}^{\infty} (2^n - 3^n)$$

$$3. \sum_{n=1}^{\infty} \frac{1+n}{2n}$$

$$4. \sum_{n=0}^{\infty} 10$$

For problems 5 - 7 assume that the n^{th} term in the sequence of partial sums for the series $\sum_{n=0}^{\infty} a_n$ is given below. Determine if the series $\sum_{n=0}^{\infty} a_n$ is convergent or divergent. If the series is convergent determine the value of the series.

$$5. s_n = (n^2 + 4n) e^{-2n}$$

$$6. s_n = \frac{1 + 2n + 3n^2}{4n^2 + 5n + 6}$$

$$7. s_n = \frac{n}{\ln(n+2)}$$

$$8. \text{ Let } d_n = \frac{7 - 8n}{4 + 3n}$$

(a) Does the sequence $\{d_n\}_{n=0}^{\infty}$ converge or diverge?

(b) Does the series $\sum_{n=0}^{\infty} d_n$ converge or diverge?

$$9. \text{ Let } d_n = 1 + ne^{-n}$$

(a) Does the sequence $\{d_n\}_{n=0}^{\infty}$ converge or diverge?

(b) Does the series $\sum_{n=0}^{\infty} d_n$ converge or diverge?

For problems 10 - 12 show that the series is divergent.

10.
$$\sum_{n=1}^{\infty} \frac{9 - 2n^2}{1 + 4n + n^2}$$

11.
$$\sum_{n=0}^{\infty} \frac{5^n + 1}{3^n}$$

12.
$$\sum_{n=1}^{\infty} \cos(n)$$

10.5 Special Series

For each of the following series determine if the series converges or diverges. If the series converges give its value.

1.
$$\sum_{n=2}^{\infty} \frac{-2}{n^2 + n}$$

2.
$$\sum_{n=1}^{\infty} \frac{12}{n}$$

3.
$$\sum_{n=1}^{\infty} 5^{n+3} 4^n$$

4.
$$\sum_{n=0}^{\infty} \frac{3}{4^{n+1} 5^{1-n}}$$

5.
$$\sum_{n=1}^{\infty} \frac{1}{14n}$$

6.
$$\sum_{n=0}^{\infty} \frac{7}{n^2 + 5n + 6}$$

7.
$$\sum_{n=1}^{\infty} 4^{1+2n} 3^{2-3n}$$

8.
$$\sum_{n=4}^{\infty} 4^{1+2n} 3^{2-3n}$$

9.
$$\sum_{n=3}^{\infty} \frac{5}{n^2 - 1}$$

10.
$$\sum_{n=4}^{\infty} \frac{1}{n^2 - 4n + 3}$$

11.
$$\sum_{n=0}^{\infty} \frac{5^{3+n}}{2^{2+3n}}$$

10.6 Integral Test

For each of the following series determine if the series converges or diverges.

1.
$$\sum_{n=2}^{\infty} \frac{4}{(\sqrt{n})^3}$$

2.
$$\sum_{n=1}^{\infty} \frac{1}{\sqrt[7]{n^2} \sqrt[6]{n}}$$

3.
$$\sum_{n=2}^{\infty} \frac{1}{2n+1}$$

4.
$$\sum_{n=0}^{\infty} \frac{8}{(n+10)^2}$$

5.
$$\sum_{n=0}^{\infty} \frac{1}{n^2+1}$$

6.
$$\sum_{n=2}^{\infty} \frac{\ln(n)}{n}$$

7.
$$\sum_{n=0}^{\infty} \frac{n^3}{n^4+1}$$

8.
$$\sum_{n=0}^{\infty} \frac{n^3}{(n^4+1)^2}$$

9.
$$\sum_{n=4}^{\infty} \frac{4}{n^2-n-6}$$

10.
$$\sum_{n=1}^{\infty} \frac{9}{n^2+5n+4}$$

11.
$$\sum_{n=0}^{\infty} n e^{-n}$$

10.7 Comparison & Limit Comparison Test

For each of the following series determine if the series converges or diverges.

1.
$$\sum_{n=0}^{\infty} \frac{3^n + n}{2^{n+1}}$$

2.
$$\sum_{n=1}^{\infty} \frac{4n - 3}{2n^5}$$

3.
$$\sum_{n=4}^{\infty} \frac{1}{(2n - 1)(n - 3)}$$

4.
$$\sum_{n=8}^{\infty} \frac{\ln(n^2)}{n}$$

5.
$$\sum_{n=1}^{\infty} \frac{4n}{(n + 1)^3}$$

6.
$$\sum_{n=0}^{\infty} \frac{n - 4}{(n^2 + 1)e^n}$$

7.
$$\sum_{n=2}^{\infty} \frac{\sqrt{2 + \cos^2(5n)}}{\sqrt{n^2 - n - 1}}$$

8.
$$\sum_{n=3}^{\infty} \frac{n - 1}{\sqrt{n^3 + n + 3}}$$

9.
$$\sum_{n=0}^{\infty} \frac{3n^2 + 7n - 1}{n^4 - n + 3}$$

10.
$$\sum_{n=1}^{\infty} \frac{(1 - \sin(n))(1 + \sin(n))}{n^2 + 8n + 1}$$

10.8 Alternating Series Test

For each of the following series determine if the series converges or diverges.

1.
$$\sum_{n=0}^{\infty} \frac{(-1)^{n+7}}{n^2 + 3}$$

2.
$$\sum_{n=0}^{\infty} \frac{(-1)^{n-2}}{3^n + 3n}$$

3.
$$\sum_{n=2}^{\infty} \frac{(-1)^{n-1}}{n^3 + 4n^2 + 8}$$

4.
$$\sum_{n=1}^{\infty} \frac{1}{(-2)^n (6n + 1)}$$

5.
$$\sum_{n=3}^{\infty} \frac{4n \cos(n\pi)}{2n^2 + 1}$$

6.
$$\sum_{n=0}^{\infty} \frac{(-1)^{n-10} n^2}{n^3 + n^2 + 4}$$

7.
$$\sum_{n=1}^{\infty} \frac{(-1)^{n+5} (2n + 1)}{n^2 + 8}$$

10.9 Absolute Convergence

For each of the following series determine if they are absolutely convergent or conditionally convergent.

1.
$$\sum_{n=2}^{\infty} \frac{(-1)^{n-2}}{\sqrt[3]{n-1}}$$

2.
$$\sum_{n=3}^{\infty} \frac{\cos(n\pi)}{n^4}$$

3.
$$\sum_{n=0}^{\infty} \frac{(-1)^{n-3}n}{4n^2+3}$$

4.
$$\sum_{n=1}^{\infty} \frac{(-1)^{n+6}(1+n^2)}{n^4}$$

5.
$$\sum_{n=2}^{\infty} \frac{\cos^3(n)}{n^3-n}$$

10.10 Ratio Test

For each of the following series determine if the series converges or diverges.

1.
$$\sum_{n=0}^{\infty} \frac{n^3 + n^2}{(n+1)!}$$

2.
$$\sum_{n=1}^{\infty} \frac{n+2}{5^{1-n}(n+1)}$$

3.
$$\sum_{n=0}^{\infty} \frac{(2n-1)!}{(3n)!}$$

4.
$$\sum_{n=0}^{\infty} \frac{(-2)^{4+n}}{3n^2 + 1}$$

5.
$$\sum_{n=2}^{\infty} \frac{4^{1+\frac{1}{2}n}n^2}{3^{2+n}(n+3)}$$

6.
$$\sum_{n=1}^{\infty} \frac{4}{(-1)^{n+2}(n^2+n+1)}$$

7.
$$\sum_{n=3}^{\infty} \frac{6^{-2n}(n-4)}{4^{3-2n}(2-n^2)}$$

8.
$$\sum_{n=2}^{\infty} \frac{(-1)^n(n+1)}{n^2+1}$$

10.11 Root Test

For each of the following series determine if the series converges or diverges.

1.
$$\sum_{n=0}^{\infty} \frac{2^{1-3n}}{(-3)^{1-2n}}$$

2.
$$\sum_{n=2}^{\infty} \left(\frac{5n^2 - 2n + 1}{3n^2 + n - 3} \right)^{-n}$$

3.
$$\sum_{n=1}^{\infty} \frac{10^{3+5n}}{n^{1+n^2}}$$

4.
$$\sum_{n=1}^{\infty} \left(\frac{6 - 9n}{2 + 4n} \right)^{\frac{1}{3}n}$$

10.12 Strategy for Series

Problems have not yet been written for this section.

I was finding it very difficult to come up with a good mix of new problems and decided my time was better spent writing problems for later sections rather than trying to come up with a sufficient number of problems for what is essentially a review section. I intend to come back at a later date when I have more time to devote to this section and add problems then.

10.13 Estimating the Value of a Series

1. Use the Integral Test and $n = 8$ to estimate the value of $\sum_{n=2}^{\infty} \frac{1}{n (\ln(n))^2}$.

2. Use the Integral Test and $n = 14$ to estimate the value of $\sum_{n=0}^{\infty} \frac{1}{(2n+1)^{\frac{5}{2}}}$.

3. Use the Comparison Test and $n = 10$ to estimate the value of $\sum_{n=0}^{\infty} \frac{3^n - 2}{2^{2n} + 1}$.

4. Use the Comparison Test and $n = 8$ to estimate the value of $\sum_{n=1}^{\infty} \frac{n^2}{n^4 + 1}$.

5. Use the Alternating Series Test and $n = 12$ to estimate the value of $\sum_{n=0}^{\infty} \frac{(-1)^n}{n+1}$.

6. Use the Alternating Series Test and $n = 18$ to estimate the value of $\sum_{n=1}^{\infty} \frac{(-1)^n \sqrt{n}}{3n+4}$.

7. Use the Ratio Test and $n = 10$ to estimate the value of $\sum_{n=1}^{\infty} \frac{(-2)^{1+2n}}{n^2 7^n}$.

8. Use the Ratio Test and $n = 5$ to estimate the value of $\sum_{n=1}^{\infty} \frac{n}{(n-1)!}$.

10.14 Power Series

For each of the following power series determine the interval and radius of convergence.

1.
$$\sum_{n=0}^{\infty} \frac{6^{1-n}}{(-2)^{3-2n}} (x+4)^n$$

2.
$$\sum_{n=0}^{\infty} \frac{(10x-1)^n}{n^{3+n}}$$

3.
$$\sum_{n=0}^{\infty} \frac{(3n)!}{(2n-2)!} (6x-9)^n$$

4.
$$\sum_{n=0}^{\infty} \frac{(-1)^n n^2}{4n+1} (5x+20)^n$$

5.
$$\sum_{n=0}^{\infty} \frac{(-1)^n 8^{1+n}}{n+4} (x-7)^n$$

6.
$$\sum_{n=1}^{\infty} \frac{2^{1+2n}}{(-3)^{1+2n} n^2} (4x+2)^n$$

7.
$$\sum_{n=0}^{\infty} \frac{(x+12)^{2+n}}{(-16)^{5+n}}$$

10.15 Power Series and Functions

For problems 1 - 4 write the given function as a power series and give the interval of convergence.

1. $f(x) = \frac{x}{1 - 8x}$

2. $f(x) = \frac{-12x^2}{1 + 6x^7}$

3. $f(x) = \frac{x^7}{8 + x^3}$

4. $f(x) = \frac{\sqrt[5]{x^2}}{4 - 3x^2}$

For problems 5 & 6 give a power series representation for the derivative of the following function.

5. $g(x) = \frac{x^{10}}{2 - x^2}$

6. $g(x) = \frac{9x^5}{1 + 3x^6}$

For problems 7 & 8 give a power series representation for the integral of the following function.

7. $h(x) = \frac{7x}{3 - 6x}$

8. $h(x) = \frac{x^4}{2 + x^9}$

10.16 Taylor Series

For problems 1 - 3 use one of the Taylor Series derived in the notes to determine the Taylor Series for the given function.

1. $f(x) = \sin(x^4)$ about $x = 0$
2. $f(x) = 9x^4 e^{-12x}$ about $x = 0$
3. $f(x) = 6x^2 \cos(7x^5)$ about $x = 0$

For problem 4 - 13 find the Taylor Series for each of the following functions.

4. $f(x) = \sin(x)$ about $x = \frac{3\pi}{2}$
5. $f(x) = e^{1-8x}$ about $x = 3$
6. $f(x) = \ln(1-x)$ about $x = -2$
7. $f(x) = \ln(2+9x)$ about $x = 1$
8. $f(x) = \frac{1}{(6-x)^7}$ about $x = 4$
9. $f(x) = \frac{1}{(4+9x)^2}$ about $x = -2$
10. $f(x) = \sqrt{2+x}$ about $x = 1$
11. $f(x) = \sqrt{1-4x}$ about $x = -3$
12. $f(x) = -3x^2 - x + 10$ about $x = -8$
13. $f(x) = x^3 + 9x^2 - 10x + 2$ about $x = 3$

10.17 Applications of Series

1. Determine a Taylor Series about $x = 0$ for the following integral.

$$\int \frac{\cos(x) - 1}{x} dx$$

2. Write down $T_2(x)$, $T_4(x)$ and $T_6(x)$ for the Taylor Series of $f(x) = \sin(x)$ about $x = \frac{3\pi}{2}$. Graph all three of the Taylor polynomials and $f(x)$ on the same graph for the interval $[-\pi, 2\pi]$.
3. Write down $T_2(x)$, $T_3(x)$ and $T_4(x)$ for the Taylor Series of $f(x) = \ln(1 - x)$ about $x = -2$. Graph all three of the Taylor polynomials and $f(x)$ on the same graph for the interval $[-4, 0]$.
4. Write down $T_1(x)$, $T_3(x)$ and $T_5(x)$ for the Taylor Series of $f(x) = \frac{1}{(6 - x)^7}$ about $x = 4$. Graph all three of the Taylor polynomials and $f(x)$ on the same graph for the interval $[1, 5]$.
5. Write down $T_2(x)$, $T_4(x)$ and $T_6(x)$ for the Taylor Series of $f(x) = \sqrt{2 + x}$ about $x = 1$. Graph all three of the Taylor polynomials and $f(x)$ on the same graph for the interval $[-2, 4]$.

10.18 Binomial Series

For problems 1 - 3 use the Binomial Theorem to expand the given function.

1. $\left(\frac{1}{2} + \frac{2}{3}x\right)^4$

2. $(1 - 8x)^5$

3. $(3 + 7x)^6$

For problems 4 - 6 write down the first four terms in the binomial series for the given function.

4. $(8 + 4x)^{-4}$

5. $\sqrt{16 + 25x}$

6. $\sqrt[4]{16 - 4x}$

11 Vectors

Once again we are completely changing topics from the last chapter. We are going to do a (very) brief introduction to vectors. We'll look at basic notation and concepts involving vectors as well as arithmetic involving vectors. We'll also look at the dot product and cross product of vectors as well as a couple of quick applications of the dot and cross product.

Once we get into the multi-variable Calculus (*i.e.* the topics usually taught in Calculus III) we'll run into vectors on a semi regular basis and so we'll need to be familiar with them and the common notation, concepts and arithmetic involving vectors.

If you are looking for some practice problems (with solutions available) please check out the [Practice Problems](#). There you will find a set of problems that should give you quite a bit practice.

11.1 Basic Concepts

1. Describe the difference between $(4, -1)$ and $\langle 4, -1 \rangle$. Illustrate the difference with a sketch.

For problems 2 - 6 give the vector for the set of points. Find its magnitude and determine if the vector is a unit vector.

2. The line segment from $(6, -2, 3)$ to $(-3, -2, 1)$.
3. The line segment from $\left(1, -\frac{1}{5}\right)$ to $\left(\frac{8}{5}, \frac{3}{5}\right)$.
4. The line segment from $(2, -1, 5)$ to $(8, -3, -6)$.
5. The position vector for $(-12, 4, 8)$.
6. The position vector for $(\cos(\theta), \sin(\theta))$ for any angle θ .
7. The vector $\vec{v} = \langle -8, -3 \rangle$ starts at the point $P = (8, 2)$. At what point does the vector end?
8. The vector $\vec{v} = \langle 0, 5, -3 \rangle$ starts at the point $P = (-1, 0, 5)$. At what point does the vector end?
9. The vector $\vec{v} = \langle -8, -3 \rangle$ ends at the point $P = (8, 2)$. At what point does the vector start?
10. The vector $\vec{v} = \langle 4, -2, 1 \rangle$ ends at the point $P = (7, -7, 2)$. At what point does the vector start?

11.2 Vector Arithmetic

- Given $\vec{a} = 3\vec{i} - 9\vec{j}$ and $\vec{b} = -6\vec{i} + \vec{j}$ compute each of the following.
 - $10\vec{b}$
 - $14\vec{a} + 20\vec{b}$
 - $\left\|8\vec{b} - \frac{1}{3}\vec{a}\right\|$
- Given $\vec{u} = \langle 0, 4, -1 \rangle$ and $\vec{v} = \langle 6, -2, -7 \rangle$ compute each of the following.
 - $\frac{3}{4}\vec{u}$
 - $-3\vec{u} - 7\vec{v}$
 - $\|\vec{v} + 10\vec{u}\|$
- Given $\vec{p} = \langle 3, -1, -2 \rangle$ and $\vec{q} = -\frac{1}{3}\vec{i} - \frac{1}{2}\vec{k}$ compute each of the following.
 - $2\vec{p}$
 - $9\vec{q} - 2\vec{p}$
 - $\|8\vec{p} - 12\vec{q}\|$
- Find a unit vector that points in the same direction as $\vec{a} = \langle 10, -3, 8, -2 \rangle$.
- Find a unit vector that points in the same direction as $\vec{w} = -\vec{i} - 6\vec{j}$.
- Find a unit vector that points in the opposite direction as $\vec{c} = 2\vec{i} + 7\vec{j} - 5\vec{k}$.
- Find a unit vector that points in the opposite direction as $\vec{b} = \langle 0, -3, -11 \rangle$.
- Find a vector that points in the same direction as $\vec{p} = 2\vec{i} - 3\vec{j} + \vec{k}$ with a magnitude of $\frac{1}{2}$.
- Find a vector that points in the opposite direction as $\vec{a} = \langle -3, -14, 2 \rangle$ with a magnitude of 32.
- Find a vector that points in the same direction as $\vec{b} = -3\vec{i} + 2\vec{k}$ with a magnitude that is $\frac{1}{10}$ the magnitude of \vec{b} .
- Determine if $\vec{p} = 8\vec{i} - 3\vec{j}$ and $\vec{q} = 16\vec{i} - 6\vec{j}$ are parallel vectors.
- Determine if $\vec{v} = \langle 1, 0, -4 \rangle$ and $\vec{w} = \langle 9, 3, 1 \rangle$ are parallel vectors.
- Determine if $\vec{a} = 10\vec{i} + 8\vec{j} + 20\vec{k}$ and $\vec{b} = \langle -35, -28, 70 \rangle$ are parallel vectors.

14. Prove the property : $\vec{u} + (\vec{v} + \vec{w}) = (\vec{u} + \vec{v}) + \vec{w}$.
15. Prove the property : $\vec{v} + \vec{0} = \vec{v}$.
16. Prove the property : $1\vec{v} = \vec{v}$.
17. Prove the property : $(a + b)\vec{v} = a\vec{v} + b\vec{v}$.

11.3 Dot Product

For problems 1 - 5 determine the dot product, $\vec{a} \cdot \vec{b}$.

1. $\vec{a} = 9\vec{i} - 8\vec{k}$, $\vec{b} = \langle 3, -2, 1 \rangle$

2. $\vec{a} = \langle 4, -1, 0, 5 \rangle$, $\vec{b} = \langle 3, 0, -10, 6 \rangle$

3. $\vec{a} = \vec{i} - 5\vec{j} - 2\vec{k}$, $\vec{b} = -4\vec{i} + 2\vec{j} + 8\vec{k}$

4. $\|\vec{a}\| = \frac{1}{4}$, $\|\vec{b}\| = \frac{9}{4}$ and the angle between the two vectors is $\theta = \pi$.

5. $\|\vec{a}\| = 24$, $\|\vec{b}\| = 9$ and the angle between the two vectors is $\theta = \frac{2\pi}{7}$.

For problems 6 - 8 determine the angle between the two vectors.

6. $\vec{p} = 9\vec{i} - \vec{j}$, $\vec{q} = -3\vec{i} - 6\vec{j}$

7. $\vec{a} = \langle 4, 0, -3 \rangle$, $\vec{b} = 2\vec{i} + 10\vec{j} - 11\vec{k}$

8. $\vec{w} = \langle 8, 3, -1, -4 \rangle$, $\vec{v} = \langle -1, 9, 4, -8 \rangle$

For problems 9 - 12 determine if the two vectors are parallel, orthogonal or neither.

9. $\vec{q} = 7\vec{i} - 14\vec{j} - 21\vec{k}$, $\vec{p} = \langle -4, 8, 12 \rangle$

10. $\vec{u} = \langle 5, 0, -2 \rangle$, $\vec{q} = \langle 4, -7, 10 \rangle$

11. $\vec{a} = 9\vec{i} - \vec{j} + 5\vec{k}$, $\vec{b} = -2\vec{i} + 7\vec{j} + \vec{k}$

12. $\vec{v} = \langle -1, 3, 1, 5 \rangle$, $\vec{w} = \langle -8, 3, -7, -2 \rangle$

13. Given that $\vec{a} \cdot \vec{b} = -6$, $\|\vec{a}\| = 4.3$ and the angle between \vec{a} and \vec{b} is $\theta = \frac{\pi}{6}$ determine if \vec{b} is a unit vector or not.

For problems 14 & 15 determine the value of b for which the two vectors will be orthogonal.

14. $\vec{u} = \langle 3, -1, 6 \rangle$, $\vec{v} = \langle 3, -2b, 1 \rangle$

15. $\vec{u} = \langle 1 - b, 4, -2 \rangle$, $\vec{v} = \langle b, 6, 3b \rangle$

16. Given $\vec{a} = \vec{i} + 3\vec{j} - 2\vec{k}$ and $\vec{b} = -3\vec{i} - 4\vec{j} + 7\vec{k}$ compute $\text{proj}_{\vec{a}} \vec{b}$.

17. Given $\vec{a} = \vec{i} + 3\vec{j} - 2\vec{k}$ and $\vec{b} = -3\vec{i} - 4\vec{j} + 7\vec{k}$ compute $\text{proj}_{\vec{b}} \vec{a}$.

18. Given $\vec{p} = \langle 5, -2, 1 \rangle$ and $\vec{q} = \langle 0, 4, 8 \rangle$ compute $\text{proj}_{\vec{p}} \vec{q}$.
19. Given $\vec{u} = \langle 1, 3, 0, -2 \rangle$ and $\vec{w} = \langle -2, 2, 4, 1 \rangle$ compute $\text{proj}_{\vec{w}} \vec{u}$.
20. Determine the direction cosines and direction angles for $\vec{r} = \langle 5, 2, -7 \rangle$.
21. Determine the direction cosines and direction angles for $\vec{r} = \left\langle \frac{1}{2}, -\frac{3}{4}, \frac{5}{2} \right\rangle$.
22. Prove the property $(c\vec{v}) \cdot \vec{w} = \vec{v} \cdot (c\vec{w})$.
23. Prove the property $\vec{v} \cdot \vec{w} = \vec{w} \cdot \vec{v}$.
24. Prove the property $\vec{v} \cdot \vec{0} = 0$.
25. Prove the property $\vec{v} \cdot \vec{v} = \|\vec{v}\|^2$.

11.4 Cross Product

1. If $\vec{w} = \langle 1, 0, -3 \rangle$ and $\vec{v} = \langle 6, -3, -4 \rangle$ compute $\vec{v} \times \vec{w}$.
2. If $\vec{w} = \langle 1, 0, -3 \rangle$ and $\vec{v} = \langle 6, -3, -4 \rangle$ compute $\vec{w} \times \vec{v}$.
3. If $\vec{a} = 3\vec{i} - 2\vec{j} + 6\vec{k}$ and $\vec{b} = \langle 4, -1, -6 \rangle$ compute $\vec{a} \times \vec{b}$.
4. Find a vector that is orthogonal to the plane containing the points $P = (-4, 2, 6)$, $Q = (-3, 2, 1)$ and $R = (2, -1, 1)$.
5. Find a vector that is orthogonal to the plane containing the points $P = (-1, 1, 6)$, $Q = (-2, 3, 2)$ and $R = (-2, 4, 5)$.
6. Are the vectors $\vec{u} = \langle -2, 4, -1 \rangle$, $\vec{v} = \langle 5, -2, -1 \rangle$ and $\vec{w} = \langle 3, 4, -3 \rangle$ are in the same plane?
7. Are the vectors $\vec{u} = \langle 1, -1, 4 \rangle$, $\vec{v} = \langle 4, 2, -2 \rangle$ and $\vec{w} = \langle -5, 4, -17 \rangle$ are in the same plane?
8. Determine the value of b so that the vectors $\vec{u} = \langle 4, -5, 3 \rangle$, $\vec{v} = \langle -2, 0, -5 \rangle$ and $\vec{w} = \langle b, -1, 6 \rangle$ are in the same plane.

12 Three Dimensional Space

In this chapter we will start looking at three dimensional space (3-D space or \mathbb{R}^3). As with the last chapter this is preparation for multi-variable Calculus (which we'll be starting in the next chapter) as the vast majority of the multi-variable Calculus material assumes we are in three dimensional (or higher dimensional) space.

In this chapter we will discuss the equations of lines and planes in three dimensional space as well as the equations of many of the standard quadric surfaces (*i.e* equations with at least one quadratic term in it).

We will define a vector function and discuss how to perform basic Calculus operations on vector functions. We will also discuss how to get tangent vectors (a vector tangent to a curve), normal vectors (a vector orthogonal/perpendicular) and the curvature of a curve from the vector function that defines the curve. We'll also have a quick discussion of how to get the velocity and acceleration of an object as it travels along a curve defined by a vector function.

We will close out the chapter with a discussion a couple of alternative coordinates systems for three dimensional space, namely, cylindrical coordinates (a 3D extension of polar coordinates) and spherical coordinates.

If you are looking for some practice problems (with solutions available) please check out the [Practice Problems](#). There you will find a set of problems that should give you quite a bit practice.

12.1 The 3-D Coordinate System

1. Give the projection of $P = (-9, 1, 5)$ onto the three coordinate planes.
2. Give the projection of $P = (3, -2, -5)$ onto the three coordinate planes.
3. Which of the points $P = (8, -9, 3)$ and $Q = (-6, 4, -5)$ is closest to the xz -plane?
4. Which of the points $P = (8, -9, 3)$ and $Q = (-6, 4, -5)$ is closest to the xy -plane?
5. Which of the points $P = (5, -4, 3)$ and $Q = (-6, 3, 9)$ is closest to the x -axis?
6. Which of the points $P = (5, -4, 3)$ and $Q = (-6, 3, 9)$ is closest to the y -axis?

For problems 7 - 9 list all of the coordinates systems (\mathbb{R} , \mathbb{R}^2 , \mathbb{R}^3) that the given equation will have a graph in. Do not sketch the graph.

7. $8z + \frac{x+1}{y^2+2} = 4x$

8. $\sqrt{y+2} = 6$

9. $7y^3 - \frac{2}{x+1} = xy$

12.2 Equations of Lines

For problems 1 - 4 give the equation of the line in vector form, parametric form and symmetric form.

1. The line through the points $(7, -3, 1)$ and $(-2, 1, 4)$.
2. The line through the point $(1, -5, 0)$ and parallel to the line given by $\vec{r}(t) = \langle 8 - 3t, -10 + 9t, -1 - t \rangle$.
3. The line through the point $(1, -7, 14)$ and parallel to the line given by $x = 6t, y = 9, z = 8 - 16t$.
4. The line through the point $(-7, 2, 4)$ and orthogonal to both $\vec{v} = \langle 0, -9, 1 \rangle$ and $\vec{w} = 3\vec{i} + \vec{j} - 4\vec{k}$.

For problems 5 - 7 determine if the two lines are parallel, orthogonal or neither.

5. The line given by $\vec{r}(t) = \langle 4 - 7t, -10 + 5t, 21 - 4t \rangle$ and the line given by $\vec{r}(t) = \langle -2 + 3t, 7 + 5t, 5 + t \rangle$.
6. The line through the points $(10, -4, 18)$ and $(5, 6, -7)$ and the line given by $x = 5 + 3t, y = -6t, z = 1 + 15t$.
7. The line given by $x = 29, y = -3 - 6t, z = 12 - t$ and the line given by $\vec{r}(t) = \langle 12 - 14t, 2 + 7t, -10 + 3t \rangle$.

For problems 8 - 10 determine the intersection point of the two lines or show that they do not intersect.

8. The line passing through the points $(0, -9, -1)$ and $(1, 6, -3)$ and the line given by $\vec{r}(t) = \langle -9 - 4t, 10 + 6t, 1 - 2t \rangle$.
9. The line given by $x = 1 + 6t, y = -1 - 3t, z = 4 + 12t$ and the line given by $x = 4 + t, y = -10 - 8t, z = 3 - 5t$.
10. The line given by $\vec{r}(t) = \langle 14 + 5t, -3t, 1 + 7t \rangle$ and the line given by $\vec{r}(t) = \langle 3 - 3t, 5 + 2t, -2 + 4t \rangle$.
11. Does the line passing through $(-5, 4, -1)$ and $(-3, -5, 0)$ intersect the yz -plane? If so, give the point.
12. Does the line given by $\vec{r}(t) = \langle 6 + t, -8 + 14t, 4t \rangle$ intersect the xz -plane? If so, give the point.
13. Which of the three coordinate planes does the line given by $x = 16t, y = -4 - 9t, z = 34$ intersect?

12.3 Equations of Planes

For problems 1 - 5 write down the equation of the plane.

1. The plane containing the points $(6, -3, 1)$, $(5, -4, 1)$ and $(3, -4, 0)$.
2. The plane containing the point $(1, -5, 8)$ and orthogonal to the line given by $x = -3 + 15t$, $y = 14 - t$, $z = 9 - 3t$.
3. The plane containing the point $(-8, 3, 7)$ and parallel to the plane given by $4x + 8y - 2z = 45$.
4. The plane containing the point $(2, 0, -8)$ and containing the line given by $\vec{r}(t) = \langle 8t, -1 - 5t, 4 - t \rangle$.
5. The plane containing the two lines given by $\vec{r}(t) = \langle 7 + 5t, 2 + t, 6t \rangle$ and $\vec{r}(t) = \langle 7 - 6t, 2 - 2t, 10t \rangle$.

For problems 6 - 8 determine if the two planes are parallel, orthogonal or neither.

6. The plane given by $-5x + 3y + 2z = -8$ and the plane given by $6x - 8z = 15$.
7. The plane given by $3x + 9y + 7z = -1$ and the plane containing the points $(1, -1, 9)$, $(4, -1, 2)$ and $(-2, 3, 4)$.
8. The plane given by $-x - 8y + 3z = 6$ and the plane given by $2x + 2y + 6z = -91$.

For problems 9 - 11 determine where the line intersects the plane or show that it does not intersect the plane.

9. The line given by $\vec{r}(t) = \langle 9 + t, -4 + t, 2 + 5t \rangle$ and the plane given by $4x - 9y + z = 6$.
10. The line given by $\vec{r}(t) = \langle 2 - 3t, 1 + t, -4 - 2t \rangle$ and the plane given by $x - 7y - 4z = -1$.
11. The line given by $x = 8$, $y = -9t$, $z = 1 + 10t$ and the plane given by $8x + 9y + 2z = 17$.

For problems 12 & 13 find the line of intersection of the two planes.

12. Find the line of intersection of the plane given by $4x + y + 10z = -2$ and the plane given by $-8x + 2y + 3z = -8$.
13. Find the line of intersection of the plane given by $x - 10y - 2z = 3$ and the plane given by $2x - y + z = -13$.

14. Determine if the line given by $x = 4 + 3t$, $y = -2$, $z = 1 + 6t$ and the plane given by $8x - y + 4z = -3$ are parallel, orthogonal or neither.

12.4 Quadric Surfaces

Sketch each of the following quadric surfaces.

1. $z^2 = x^2 + \frac{y^2}{2}$

2. $z = 2 + 4x^2 + 6y^2$

3. $4x^2 + y^2 + 3z^2 = 1$

4. $\frac{x^2}{9} + \frac{y^2}{16} = 1$

5. $y = \frac{x^2}{2} + \frac{z^2}{3} - 7$

6. $6x^2 + 2z^2 = 1$

7. $x = 12 - \frac{y^2}{4} - 3z^2$

8. $x^2 = 4y^2 + 9z^2$

12.5 Functions of Several Variables

For problems 1 - 6 find the domain of the given function.

1. $f(x, y) = \sqrt{2x + 4y - 1}$

2. $f(x, y) = \ln\left(\frac{1}{x - y}\right)$

3. $f(x, y) = \sqrt{\frac{1}{x^2} - \frac{1}{y^2}}$

4. $f(x, y, z) = \frac{1}{x + 1} + \frac{1}{y - 1} + \frac{1}{x + y - z}$

5. $f(x, y, z) = \ln(x^2 + y^2 - 8z)$

6. $f(x, y) = \sqrt{x + y} - \sqrt{x - 3}$

For problems 7 - 11 identify and sketch the level curves (or contours) for the given function.

7. $x^2 - 4z - y = 2$

8. $x - 4z - y^2 = 2$

9. $z^2 + 4x^2 = 1 - 4y^2$

10. $z + 4x^2 = 1 - 4y^2$

11. $2x - 6y + z = -2$

For problems 12 - 14 identify and sketch the traces for the given curves.

12. $x^2 - 4z - y = 2$

13. $z^2 + 4x^2 = 1 - 4y^2$

14. $2x - 6y + z = -2$

12.6 Vector Functions

For problems 1 - 3 find the domain of the given vector function.

1. $\vec{r}(t) = \left\langle \frac{1}{t^2 - 1}, \frac{1}{t + 3}, \frac{1}{t - 6} \right\rangle$

2. $\vec{r}(t) = \langle \sqrt{t}, \sqrt{t + 1}, \sqrt{t + 2} \rangle$

3. $\vec{r}(t) = \langle \ln(t + 7), \ln(t - 3) \rangle$

For problems 4 - 8 sketch the graph of the given vector function.

4. $\vec{r}(t) = \langle -4, t + 1 \rangle$

5. $\vec{r}(t) = \langle -2 \cos(t), 5 \sin(t) \rangle$

6. $\vec{r}(t) = \langle \sqrt{t + 2}, 1 - t \rangle$

7. $\vec{r}(t) = \langle 2t + 1, t^2 - 1 \rangle$

8. $\vec{r}(t) = \langle t^2 + 4, 6 - t^2 \rangle$

For problems 9 - 12 identify the graph of the vector function without sketching the graph.

9. $\vec{r}(t) = \langle 6, 2 + 8t, -1 + 10t \rangle$

10. $\vec{r}(t) = \langle 12t, 6 - 8t, 4 + 7t \rangle$

11. $\vec{r}(t) = \langle 2, 6 \cos(t), 6 \sin(t) \rangle$

12. $\vec{r}(t) = \langle -2t, 6 \cos(t), 6 \sin(t) \rangle$

For problems 13 - 16 write down the equation of the line segment between the two points.

13. The line segment starting at $(4, -7)$ and ending at $(2, 0)$.

14. The line segment starting at $(-1, 2)$ and ending at $(7, -2)$.

15. The line segment starting at $(4, 1, -3)$ and ending at $(-1, 2, 6)$.

16. The line segment starting at $(1, -1, 9)$ and ending at $(4, -7, 10)$.

12.7 Calculus with Vector Functions

For problems 1 - 6 evaluate the given limit.

$$1. \lim_{t \rightarrow 0} \left(\cos(2t) \vec{i} - e^{4-t} \vec{j} + (t^2 + 3t - 9) \vec{k} \right)$$

$$2. \lim_{t \rightarrow 4} \left\langle \frac{t-4}{t^2-3t-4}, \frac{t^2-4t}{16-t^2} \right\rangle$$

$$3. \lim_{t \rightarrow 0} \left\langle \frac{\sin(t)}{2t}, \frac{1-\cos(t)}{t}, -3 \right\rangle$$

$$4. \lim_{t \rightarrow -8} \left(\frac{e^{t^2-64} - 1}{t+8} \vec{i} + \frac{\sin(t+8)}{t+8} \vec{j} - \vec{k} \right)$$

$$5. \lim_{t \rightarrow -\infty} \left\langle \frac{5t^2 - 8t + 1}{12 + 5t^2}, \frac{2 + t^3}{1 + t^2 + t^4} \right\rangle$$

$$6. \lim_{t \rightarrow \infty} \left\langle \ln \left(1 - \frac{4}{t} \right), e^{\frac{1}{t^2}}, 2 \right\rangle$$

For problems 7 - 11 compute the derivative of the given vector function.

$$7. \vec{r}(t) = \left\langle \sqrt{3t}, \frac{1}{t^4}, \frac{1}{2t} \right\rangle$$

$$8. \vec{r}(t) = \cos(2t) \vec{i} - \sin(2t) \vec{j} + \ln(2t) \vec{k}$$

$$9. \vec{r}(t) = \left\langle e^{t^2-1}, 4 - \sec(2t), 7 \right\rangle$$

$$10. \vec{r}(t) = \sin(t) \cos(t) \vec{i} - t^3 \ln(t^2) \vec{j}$$

$$11. \vec{r}(t) = \left\langle \frac{1}{(t^2-4)^2}, \frac{t^3}{t^2+2}, \frac{t^2+2}{t^3} \right\rangle$$

For problems 12 - 15 evaluate the given integral.

$$12. \int \vec{r}(t) dt, \text{ where } \vec{r}(t) = \left\langle \frac{1}{t^3} - t^3, 5t, \frac{1}{6t} - \frac{8}{t^4} \right\rangle$$

$$13. \int \vec{r}(t) dt, \text{ where } \vec{r}(t) = (t^2 - 5) e^{t^3-15t} \vec{i} + 4t\sqrt{t^2+1} \vec{j} - \sin^2(5t) \vec{k}$$

$$14. \int_0^1 \vec{r}(t) dt \text{ where } \vec{r}(t) = \langle t \cos(\pi t), 8t - 2, 12t^3 - e^{2t} \rangle$$

15. $\int_1^{-1} \vec{r}(t) dt$ where $\vec{r}(t) = \tan(t) \vec{i} - \sin^3(t) \cos^2(t) \vec{j} - 8t$

12.8 Tangent, Normal and Binormal Vectors

For problems 1 - 3 find the unit tangent vector for the given vector function.

1. $\vec{r}(t) = t^2 \vec{i} - \cos(8t) \vec{j} + \sin(8t) \vec{k}$

2. $\vec{r}(t) = \langle 8t, 2 - t^6, t^4 \rangle$

3. $\vec{r}(t) = \langle \ln(6t), e^{1-t}, 5t \rangle$

For problems 4 & 5 find the tangent line to the vector function at the given point.

4. $\vec{r}(t) = \langle 3 + t^2, t^4, 6 \rangle$ at $t = -1$.

5. $\vec{r}(t) = \langle 2t, \cos^2(t), e^{6t} \rangle$ at $t = 0$.

For problems 6 & 7 find the unit normal and the binormal vectors for the given vector function.

6. $\vec{r}(t) = \langle e^{4t} \sin(t), e^{4t} \cos(t), 2 \rangle$

7. $\vec{r}(t) = 2t \vec{i} + \frac{1}{2}t^2 \vec{j} + \ln(t^2) \vec{k}$

12.9 Arc Length with Vector Functions

For problems 1 - 3 determine the length of the vector function on the given interval.

1. $\vec{r}(t) = 4 \cos(2t) \vec{i} + 3t \vec{j} - 4 \sin(2t) \vec{k}$ from $0 \leq t \leq 3\pi$.

2. $\vec{r}(t) = \langle 9 - 2t, 4 + 2t, \sqrt{2}t^2 \rangle$ from $0 \leq t \leq 1$.

3. $\vec{r}(t) = 2t \vec{i} + \frac{1}{2}t^2 \vec{j} + \ln(t^2) \vec{k}$ from $1 \leq t \leq 3$.

For problems 4 - 6 find the arc length function for the given vector function.

4. $\vec{r}(t) = \langle 8t, 6 + t, -7t \rangle$

5. $\vec{r}(t) = \langle 8t, 4t^{\frac{3}{2}}, 3 \rangle$

6. $\vec{r}(t) = \langle e^{4t} \sin(t), e^{4t} \cos(t), 2 \rangle$

7. Determine where on the curve given by $\vec{r}(t) = \langle 8t, 4t^{\frac{3}{2}}, 3 \rangle$ we are after traveling a distance of 4.

8. Determine where on the curve given by $\vec{r}(t) = \langle e^{4t} \sin(t), e^{4t} \cos(t), 2 \rangle$ we are after traveling a distance of 15.

12.10 Curvature

Find the curvature for each the following vector functions.

1. $\vec{r}(t) = \langle 5t, 1 - 2t, 4t^{\frac{3}{2}} \rangle$

2. $\vec{r}(t) = \langle 6, e^{-5t}, 3te^{-5t} \rangle$

3. $\vec{r}(t) = \langle \cos(\omega t), t, \sin(\omega t) \rangle$

12.11 Velocity and Acceleration

1. An objects acceleration is given by $\vec{a} = \cos(2t)\vec{i} + 4t^3\vec{j} + 6\sin(3t)\vec{k}$. The objects initial velocity is $\vec{v}(0) = 6\vec{i} + 2\vec{j} + 7\vec{k}$ and the objects initial position is $\vec{r}(0) = \vec{i} - 9\vec{j} + 6\vec{k}$. Determine the objects velocity and position functions.
2. An objects acceleration is given by $\vec{a} = 10t\vec{i} - 6\vec{j} + t\cos(t)\vec{k}$. The objects initial velocity is $\vec{v}(0) = -\vec{i} + 11\vec{j} - \vec{k}$ and the objects initial position is $\vec{r}(0) = 4\vec{i} + \vec{j} + 10\vec{k}$. Determine the objects velocity and position functions.
3. Determine the tangential and normal components of acceleration for the object whose position is given by $\vec{r}(t) = \langle 5t, 1 - 2t, 4t^{\frac{3}{2}} \rangle$.
4. Determine the tangential and normal components of acceleration for the object whose position is given by $\vec{r}(t) = \langle 6, \mathbf{e}^{-5t}, 3t\mathbf{e}^{-5t} \rangle$.

12.12 Cylindrical Coordinates

For problems 1 & 2 convert the Cartesian coordinates for the point into Cylindrical coordinates.

1. $(-3, 5, -8)$

2. $(4, 1, 7)$

3. Convert the following equation written in Cartesian coordinates into an equation in Cylindrical coordinates. $\frac{x - y}{x^2 + y^2 + 1} = xyz$

For problems 4 - 6 convert the equation written in Cylindrical coordinates into an equation in Cartesian coordinates.

4. $zr^3 \cos(\theta) = 4r + 8$

5. $r^2 - 3 \sin(\theta) = z^3 + \sqrt{r^2 + 1}$

6. $\tan(\theta) + 2z = 1 - r^2$

For problems 7 - 9 identify the surface generated by the given equation.

7. $z = -4r, z < 0$

8. $2r + 6 \cos(\theta) + 18 \sin(\theta) = \frac{51}{r}$

9. $\theta = \frac{\pi}{3}$

12.13 Spherical Coordinates

For problems 1 - 3 convert the Cartesian coordinates for the point into Spherical coordinates.

1. $(6, 2, -8)$
2. $(-1, 5, 2)$
3. $(-3, -2, 1)$
4. Convert the Cylindrical coordinates for the point $(5, 1.294, 6)$ into Spherical coordinates.
5. Convert the following equation written in Cartesian coordinates into an equation in Spherical coordinates.

$$\frac{xz}{y} = 2 - x$$

For problems 6 - 8 convert the equation written in Spherical coordinates into an equation in Cartesian coordinates.

6. $\rho \cos(\varphi) \sin(\varphi) \sin(\theta) = 3$
7. $\rho - \cos(\varphi) = 2 + \cos^2(\varphi)$
8. $\tan(\varphi) (\cos(\theta) - \sin(\theta)) = 4$

For problems 9 & 10 identify the surface generated by the given equation.

9. $\cos^2(\varphi) - \sin^2(\varphi) = 0$
10. $\sin(\varphi)\cos\theta + \sin\varphi\sin\theta + \cos(\varphi) = \frac{1}{\rho}$

13 Partial Derivatives

To this point, with the exception of the occasional section in the last chapter, we've been working almost exclusively with functions of a single variable. It is not time to formally start multi-variable Calculus, *i.e.* Calculus involving functions of two or more variables. We will be covering the same basic topics as we do with single variable Calculus. Namely, limits, derivatives and integrals.

In this chapter we will open up with a quick section discussing taking limits of multi-variable functions. We will only be covering limits of multi-variable functions with a single chapter because, as we'll see, many of the concepts from single variable limits still hold, with some natural extensions of course. However, as we'll also see the work will often be significantly longer/harder and so we won't be spending a lot of time discussing limits of multi-variable functions. Luckily enough for us we also won't need to worry all that much about limits of multi-variable functions so the quick discussion of limits in this chapter will suffice.

The rest of the chapter will be discussing how to take derivatives of multi-variable functions. We want to keep the "main" interpretation of derivatives, namely the derivative will still give the rate of change of the function. The issue here is that because we have multiple variables the function can have differing rates of change depending on how we allow the various variables to change.

So, to start out the derivative discussion we will start by defining the partial derivative. These will restrict just how we allow the various variables to change. We will eventually introduce the directional derivative which will allow the variables to change in any arbitrary manner. In the process of introducing the idea of a directional derivative we'll also introduce the concept of a gradient of a function. The gradient will arise in quite a few sections throughout the rest of this multi-variable Calculus material, including integrals.

Finally, as we'll see, if you can take derivatives of single variable functions then you have the majority of the knowledge that you need to take derivatives of multi-variable functions. There are, however, some subtleties that we'll need to remember to deal with. Those subtleties are, generally, the issues that most students run into when taking derivatives of multi-variable functions.

If you are looking for some practice problems (with solutions available) please check out the [Practice Problems](#). There you will find a set of problems that should give you quite a bit practice.

13.1 Limits

Evaluate each of the following limits.

$$1. \quad \lim_{(x,y,z) \rightarrow (2,1,0)} \frac{(4y - z^3) e^{3x-6}}{4z - yx^2}$$

$$2. \quad \lim_{(x,y) \rightarrow (3,-7)} \frac{6x - y + xy}{2x^3 + y^3}$$

$$3. \quad \lim_{(x,y) \rightarrow (-3,4)} \frac{4x^2 - xy - 3y^2}{12x^2 + 17xy + 6y^2}$$

$$4. \quad \lim_{(x,y) \rightarrow (-1,10)} \frac{10x^2 + 11xy + y^2}{10x^2 - 39xy - 4y^2}$$

$$5. \quad \lim_{(x,y) \rightarrow (0,0)} \frac{2x^2 + 7y^2}{4y^2 + x^2}$$

$$6. \quad \lim_{(x,y) \rightarrow (0,0)} \frac{6 \sqrt[3]{x} - 3y^{10}}{9y^{30} + 2x}$$

$$7. \quad \lim_{(x,y) \rightarrow (0,0)} \frac{2x^4y}{x^8 + 6y^2}$$

13.2 Partial Derivatives

For problems 1 - 13 find all the 1st order partial derivatives.

$$1. f(x, y, z) = x^3 \sqrt{y} + 4z^3 y^2 - xyz + x^2 - \sqrt[3]{z^5}$$

$$2. W(a, b, c, d) = a^2 + b^3 - c^2 d^4 - 5a^3 c - d^6 b^2 a$$

$$3. A(p, t, u) = \frac{1}{p t^2} - \frac{t^3}{u^2} + \frac{4u p}{t^4}$$

$$4. g(x, y, z) = \sqrt{x^2 + z^{-2}} + \sin(xy - x^2)$$

$$5. f(s, t) = \cos(se^{t^2}) + \cos(s + e^{t^2})$$

$$6. f(x, y) = \ln\left(\frac{y}{x}\right) + \ln\left(\frac{1}{x+y}\right) - \ln\left(\frac{x}{6}\right)$$

$$7. A(y, z) = \frac{1}{y - 4z^5} + \tan(yz^2 - y^3)$$

$$8. g(u, v) = \frac{u}{v} \cos\left(\frac{v}{u}\right) + 4u - v^2 u$$

$$9. w = (x - y) e^{4x+z^6} - \sin(2x + 7z) \sec(yz^3)$$

$$10. f(u, v, w) = (uw + 4) \sin^{-1}(u^2 + v^2) - \ln\left(\frac{w^2}{v^4}\right)$$

$$11. f(x, y, z) = \sin\left(\frac{z}{z^2 + x}\right) - \frac{6x^2 + y}{y^2 - z^2}$$

$$12. g(s, t, p) = \frac{p^3 t^2}{s^2 + 1} + \frac{(4s - 1)t^2}{6 - s}$$

$$13. f(x, y, z, w) = x^2 \sin(4y) + z^3(6x - y) + y^4$$

For problems 14 & 15 find $\frac{\partial z}{\partial x}$ and $\frac{\partial z}{\partial y}$ for the given function.

$$14. z^4 - y^2 + x^2 = 6x^2 y^3 z^7$$

$$15. x^2 \sin(z) + (x^2 - 1)y^4 = z^6$$

13.3 Interpretations of Partial Derivatives

1. Determine if $f(x, y) = 10 - x^2 - y^2$ is increasing or decreasing at $(7, -3)$ if
 - (a) we allow x to vary and hold y fixed.
 - (b) we allow y to vary and hold x fixed.
2. Determine if $f(x, y) = xe^{x-y} + 100y$ is increasing or decreasing at $(-2, 1)$ if
 - (a) we allow x to vary and hold y fixed.
 - (b) we allow y to vary and hold x fixed.
3. Determine if $f(x, y) = \frac{x+y}{y-x}$ is increasing or decreasing at $(0, 7)$ if
 - (a) we allow x to vary and hold y fixed.
 - (b) we allow y to vary and hold x fixed.
4. Write down the vector equations of the tangent lines to the traces for $f(x, y) = \sin(x) \cos(y)$ at $\left(\frac{\pi}{3}, -\frac{\pi}{4}\right)$.
5. Write down the vector equations of the tangent lines to the traces for $f(x, y) = \ln\left(\frac{x}{y^2}\right)$ at $(6, 2)$.

13.4 Higher Order Partial Derivatives

For problems 1 - 3 verify Clairaut's Theorem for the given function.

1. $Q(s, t) = \ln(st) - s^4 \sin(6t) + st$

2. $f(u, w) = \sin(uw) + 4u^2w^{-2}$

3. $f(x, y) = e^{xy} \sin(y)$

For problems 4 - 9 find all 2nd order derivatives for the given function.

4. $h(x, y) = x^4y^{-2} - 4xy + e^{7y} + \ln(2x)$

5. $A(u, v) = u^2 \cos(3v) + \ln\left(\frac{u}{4v^2}\right)$

6. $g(v, w) = \ln(v \sin(w)) + \sin(v \ln(w))$

7. $f(x, y) = \cos(x^2 + y^2) - \sin(xy)$

8. $h(x, y, z) = 7x^3y^2z^4 + 8$

9. $Q(u, v, w) = u^4 \sin(w^2) - \frac{2v}{u^4} + \ln(v^2w)$

For problems 10 & 11 find all 3rd order derivatives for the given function.

10. $h(x, y) = x^4y^5 - 5\sqrt{x} + 8y^2$

11. $A(u, v) = u^3 \sin(2v) - \frac{u^3}{v^2}$

12. Given $f(x, y, z) = e^{-z} \cos(4y) \ln(2x)$ find f_{xyyzxz} .

13. Given $w = \ln\left(\frac{xy}{z}\right) + 8x^4y^3\sqrt{z}$ find $\frac{\partial^5 w}{\partial x \partial z^2 \partial y \partial x}$.

14. Given $h(u, v) = \cos(u^4 + u^2 + 1) - \frac{\sqrt{u}}{v^3}$ find $\frac{\partial^7 h}{\partial u^2 \partial v \partial u^4}$.

15. Given $f(x, y) = \frac{x^6}{1+6y} - \cos(x^2) + 6e^x \sin(y)$ find f_{xxxyyx} .

13.5 Differentials

Compute the differential of each of the following functions.

1. $w = \frac{x^4 z^8}{y}$

2. $f(x, y) = \tan(xy^2)$

3. $A(x, y, z) = z^3 e^{xz} \sec(y)$

13.6 Chain Rule

1. Given the following information use the Chain Rule to determine $\frac{dz}{dt}$.

$$z = e^{x^2-y} \quad x = \sin(4t), \quad y = t^3 - 9$$

2. Given the following information use the Chain Rule to determine $\frac{dw}{dt}$.

$$w = x^4 - 4xy^2 + z^3 \quad x = \sqrt{t}, \quad y = e^{2t}, \quad z = \frac{1}{t}$$

3. Given the following information use the Chain Rule to determine $\frac{dw}{dt}$.

$$w = \frac{4x}{yz^3} \quad x = 7t - 1, \quad y = 1 - 2t, \quad z = t^4$$

4. Given the following information use the Chain Rule to determine $\frac{dz}{dx}$.

$$z = 2x^3 e^{4y} \quad y = \cos(6x)$$

5. Given the following information use the Chain Rule to determine $\frac{dz}{dx}$.

$$z = \tan\left(\frac{x}{y}\right) \quad y = e^{x^2}$$

6. Given the following information use the Chain Rule to determine $\frac{\partial z}{\partial u}$ and $\frac{\partial z}{\partial v}$.

$$z = x \sin(y^2 - x) \quad x = 3u - v^2, \quad y = u^6$$

7. Given the following information use the Chain Rule to determine w_u and w_v .

$$w = x^4 y^{-3} z^2 \quad x = u^2 v, \quad y = 3 - uv, \quad z = 7u^2 - 10v$$

8. Given the following information use the Chain Rule to determine $\frac{\partial z}{\partial t}$ and $\frac{\partial z}{\partial s}$.

$$z = 6x + y^2 \tan(x) \quad x = p^2 - 3t, \quad y = s^2 - t^2, \quad p = e^{3s}$$

9. Given the following information use the Chain Rule to determine w_p and w_t .

$$w = x^2 y^4 z^6 - 2xy \quad x = 2p, \quad y = 3tq, \quad z = 3tp^2, \quad q = 2t$$

10. Given the following information use the Chain Rule to determine $\frac{\partial w}{\partial u}$ and $\frac{\partial w}{\partial v}$.

$$w = \frac{\sqrt{y}}{x^2 z^3} \quad x = uv, \quad y = u^2 - p^3, \quad z = 4qp, \quad p = 2u - 3v, \quad q = v^2$$

11. Determine formulas for w_u and w_t for the following situation.

$$w = w(x, y) \quad x = x(y, z), \quad y = y(u, v), \quad z = z(u, t), \quad v = v(t)$$

12. Determine formulas for $\frac{\partial w}{\partial s}$ and $\frac{\partial w}{\partial t}$ for the following situation.

$$w = w(x, y, z) \quad x = x(u, v, t), \quad y = y(p), \quad z = z(u, t), \quad v = v(p, t), \quad p = p(s, t)$$

13. Compute $\frac{dy}{dx}$ for the following equation.

$$\cos(2x + 3y) = x^5 - 8y^2$$

14. Compute $\frac{dy}{dx}$ for the following equation.

$$\cos(2x) \sin(3y) - xy = y^4 + 9$$

15. Compute $\frac{\partial z}{\partial x}$ and $\frac{\partial z}{\partial y}$ for the following equation.

$$z^3 y^4 - x^2 \cos(2y - 4z) = 4z$$

16. Compute $\frac{\partial z}{\partial x}$ and $\frac{\partial z}{\partial y}$ for the following equation.

$$\sin(x) e^{4xz} + 2z^2 y = \cos(z)$$

17. Determine f_{uu} and f_{vv} for the following situation.

$$f = f(x, y) \quad x = e^u \sin(v), \quad y = e^u \cos(v)$$

18. Determine f_{uu} and f_{vv} for the following situation.

$$f = f(x, y) \quad x = u^2 - v^2, \quad y = \frac{u}{v}$$

13.7 Directional Derivatives

For problems 1 - 4 determine the gradient of the given function.

1. $f(x, y) = y^3x^5 + \ln(xy)$
2. $f(x, y) = e^{\frac{x}{y}} + y^4 \sin(xy)$
3. $f(x, y, z) = 4z - \frac{y^4}{2z^3} + \sqrt{x^3}(z - 1)$
4. $f(x, y, z) = \cos\left(\frac{xy}{z}\right) + z^3y^2x$

For problems 5 - 8 determine $D_{\vec{u}}f$ for the given function in the indicated direction.

5. $f(x, y) = \ln(2xy) - \sin(x^2 + y^2)$ in the direction of $\vec{v} = \langle 7, -3 \rangle$
6. $f(x, y) = 4x^2y^3 - \sqrt{2x + 5y}$ in the direction of $\vec{v} = \langle -1, 4 \rangle$
7. $f(x, y, z) = 8xy^2 - \frac{5z^2}{x} + y^4$ in the direction of $\vec{v} = \langle -4, 1, 2 \rangle$
8. $f(x, y, z) = \frac{3x}{y^2 - z^3} + 5x^2 - 8y$ in the direction of $\vec{v} = \langle 0, 3, -2 \rangle$
9. Determine $D_{\vec{u}}f(-1, 4, 6)$ for $f(x, y, z) = e^{xy^2} + 4zy^3$ direction of $\vec{v} = \langle 2, -3, 6 \rangle$.
10. Determine $D_{\vec{u}}f(8, 1, 2)$ for $f(x, y, z) = \ln\left(\frac{x}{z}\right) + \ln\left(\frac{z}{y}\right) + y^2x$ direction of $\vec{v} = \langle 1, 5, 2 \rangle$.

For problems 11 - 13 find the maximum rate of change of the function at the indicated point and the direction in which this maximum rate of change occurs.

11. $f(x, y) = e^{4xy}$ at $(6, -2)$
12. $f(x, y, z) = x^2y^4 - 3z^2x$ at $(1, -6, 3)$
13. $f(x, y, z) = \ln\left(\frac{2x + 3y}{z}\right)$ at $(2, 7, 4)$
14. Given $\vec{u} = \left\langle -\frac{3}{5}, -\frac{4}{5} \right\rangle$, $\vec{v} = \left\langle \frac{4}{\sqrt{20}}, \frac{2}{\sqrt{20}} \right\rangle$, $\vec{w} = \left\langle -\frac{3}{\sqrt{11}}, -\frac{2}{\sqrt{11}} \right\rangle$, $D_{\vec{u}}(-1, 4) = \frac{14}{5}$ and $D_{\vec{v}}(-1, 4) = -\frac{22}{\sqrt{20}}$ determine the value of $D_{\vec{w}}(-1, 4)$.

15. Given $\vec{u} = \left\langle \frac{1}{\sqrt{15}}, \frac{4}{\sqrt{15}} \right\rangle$, $\vec{v} = \left\langle -\frac{3}{\sqrt{34}}, -\frac{5}{\sqrt{34}} \right\rangle$, $\vec{w} = \left\langle -\frac{1}{\sqrt{2}}, \frac{1}{\sqrt{2}} \right\rangle$, $D_{\vec{u}}(0, 1) = \frac{18}{\sqrt{15}}$ and $D_{\vec{v}}(0, 1) = -\frac{40}{\sqrt{34}}$ determine the value of $D_{\vec{w}}(0, 1)$.

14 Applications of Partial Derivatives

In this chapter we'll take a look at a couple of applications of partial derivatives. The applications here are either very similar to applications we saw for derivatives of single variable functions or extensions of those applications.

For example we will be looking at the tangent plane to a surface rather than tangent lines to curves as we did with single variable functions.

In addition we be finding relative and absolute extrema of multi-variable functions. The difference in this chapter compared to the last time we saw these applications is that they will often involve a lot more work. Because of the increased difficulty of the problems we'll be restricting ourselves to finding the relative and absolute extrema of functions of two variables only.

We will also be looking at Lagrange Multipliers. This is a method that will allow us to optimize a function that is subject to some constraint. That is to say optimizing a function of two or three variables where the variables must also satisfy some constraint (usually in the form on an equation involving the variables).

If you are looking for some practice problems (with solutions available) please check out the [Practice Problems](#). There you will find a set of problems that should give you quite a bit practice.

14.1 Tangent Planes and Linear Approximations

1. Find the equation of the tangent plane to $z = x^2y^4 - \frac{12x}{y}$ at $(-1, 6)$.
2. Find the equation of the tangent plane to $z = \ln(x^2y) - x\sqrt{y}$ at $\left(-\frac{1}{2}, 4\right)$.
3. Find the equation of the tangent plane to $z = e^{xy} + y^2e^{1-y}$ at $(0, 1)$.
4. Find the linear approximation to $z = \cos(\sin(y) - x)$ at $(-2, 0)$.
5. Find the linear approximation to $z = \frac{10x^2}{x - y}$ at $(4, -1)$.

14.2 Gradient Vector, Tangent Planes and Normal Lines

1. Find the tangent plane and normal line to $zy + 4x\sqrt{z} - x^3y^2 = 221$ at $(-2, 5, 9)$.
2. Find the tangent plane and normal line to $e^{xy^2} + zy^4 = 61 + \frac{z^2}{x+1}$ at $(0, -2, 6)$.
3. Find the tangent plane and normal line to $9yz - \sqrt{x^2 - 8z} = xy^2 - 26$ at $(3, 1, -2)$.
4. Find the point(s) on $6x^2 + y^2 - 3z^2 = 4$ where the tangent plane to the surface is parallel to the plane given by $2x + 7y - z = 6$.
5. Find the point(s) on $x^2 - 8y^2 - 2z^2 = -3$ where the tangent plane to the surface is parallel to the plane given by $-4x - y + 8z = 1$.

14.3 Relative Minimums and Maximums

Find and classify all the critical points of the following functions.

1. $f(x, y) = 2y - 9x - xy + 5x^2 + y^2$

2. $f(x, y) = x^3 - y^3 + 8xy$

3. $f(x, y) = (y - x)(1 - 2x - 3y)$

4. $f(x, y) = \frac{1}{2}x^4 - 4xy^2 - 2x^2 + 8y^2$

5. $f(x, y) = xy e^{-8(x^2+y^2)}$

6. $f(x, y) = 8x - x\sqrt{y-1} + x^3 + \frac{1}{2}y - 12x^2$

14.4 Absolute Extrema

1. Find the absolute minimum and absolute maximum of $f(x, y) = 18x^2 + 4y^2 - y^2x - 2$ on the triangle with vertices $(-1, -1)$, $(5, -1)$ and $(5, 17)$.
2. Find the absolute minimum and absolute maximum of $f(x, y) = 2x^3 - 4y^3 + 24xy$ on the rectangle given by $0 \leq x \leq 5$, $-3 \leq y \leq -1$.
3. Find the absolute minimum and absolute maximum of $f(x, y) = x^2 - y^2 + xy - 5x$ on the region bounded by $y = 5 - x^2$ and the x -axis.

14.5 Lagrange Multipliers

1. Find the maximum and minimum values of $f(x, y) = 10y^2 - 4x^2$ subject to the constraint $x^4 + y^4 = 1$.
2. Find the maximum and minimum values of $f(x, y) = 3x - 6y$ subject to the constraint $4x^2 + 2y^2 = 25$.
3. Find the maximum and minimum values of $f(x, y) = xy$ subject to the constraint $x^2 - y = 12$. Assume that $y \leq 0$ for this problem. Why is this assumption needed?
4. Find the maximum and minimum values of $f(x, y, z) = x^2 + 3y^2$ subject to the constraint $x^2 + 4y^2 + z^2 = 36$.
5. Find the maximum and minimum values of $f(x, y, z) = xyz$ subject to the constraint $x^2 + 2y^2 + 4z^2 = 24$.
6. Find the maximum and minimum values of $f(x, y, z) = 2x + 4y + z^2$ subject to the constraints $y^2 + z^2 = 1$ and $x^2 + z^2 = 1$.
7. Find the maximum and minimum values of $f(x, y, z) = x + y + z^2$ subject to the constraints $x + y + z = 1$ and $x^2 + z^2 = 1$.

15 Multiple Integrals

We now need to start discussing integration of multi-variable functions.

When we looked at definite integrals of single variable functions the values of the independent variable were in some interval $[a, b]$. For functions of multiple variables the values of the independent variables will not just come from intervals anymore. For functions of two variables, for example, the values of the independent variables will come from a two dimensional region. Likewise, for functions of three variables the values of the independent variables will come from a three dimensional region.

We will be discussing Double Integrals (for integrating functions of two variables) and Triple Integrals (for integrating functions of three variables). While most of the integration will be done in terms of Cartesian coordinates we will also discuss converting integrals from Cartesian coordinates into Polar coordinates (for functions of two variables) and Cylindrical or Spherical coordinates (for functions of three variables).

We will also formalize the process for converting an integral from one coordinate system into another. In the process we will derive some of the formulas that were using to convert integrals from Cartesian into Polar, Cylindrical or Spherical coordinates.

If you are looking for some practice problems (with solutions available) please check out the [Practice Problems](#). There you will find a set of problems that should give you quite a bit practice.

15.1 Double Integrals

1. Use the Midpoint Rule to estimate the volume under $f(x, y) = 4x + 8y$ and above the rectangle given by $0 \leq x \leq 4$, $2 \leq y \leq 6$ in the xy -plane. Use 4 subdivisions in the x direction and 4 subdivisions in the y direction.
2. Use the Midpoint Rule to estimate the volume under $f(x, y) = 4x - y^2$ and above the rectangle given by $0 \leq x \leq 2$, $-2 \leq y \leq 1$ in the xy -plane. Use 2 subdivisions in the x direction and 3 subdivisions in the y direction.

15.2 Iterated Integrals

1. Compute the following double integral over the indicated rectangle **(a)** by integrating with respect to x first and **(b)** by integrating with respect to y first.

$$\iint_R 16xy - 9x^2 + 1 \, dA \quad R = [2, 3] \times [-1, 1]$$

2. Compute the following double integral over the indicated rectangle **(a)** by integrating with respect to x first and **(b)** by integrating with respect to y first.

$$\iint_R \cos(x) \sin(y) \, dA \quad R = \left[\frac{\pi}{6}, \frac{\pi}{4}\right] \times \left[\frac{\pi}{4}, \frac{\pi}{3}\right]$$

For problems 3 - 16 compute the given double integral over the indicated rectangle.

$$3. \iint_R 8x^3 - 4 \, dA \quad R = [-3, -1] \times [0, 4]$$

$$4. \iint_R 15y^4 + \frac{2}{x^2} \, dA \quad R = [1, 2] \times [1, 4]$$

$$5. \iint_R 4y \sec^2(x) + \frac{2x}{y} \, dA \quad R = \left[0, \frac{\pi}{4}\right] \times [1, 5]$$

$$6. \iint_R y^5 - x^2 e^y \, dA \quad R = [-1, 2] \times [-3, 3]$$

$$7. \iint_R \frac{x^3}{1+x^4} - \frac{1}{e^{3y}} \, dA \quad R = [-1, 0] \times [0, 4]$$

$$8. \iint_R x e^{x^2} - 12x^3 \sin(\pi y) \, dA \quad R = [-2, 0] \times \left[\frac{1}{2}, 1\right]$$

$$9. \iint_R x \cos(4y + 3x^2) \, dA \quad R = [0, \sqrt{\pi}] \times \left[\frac{\pi}{2}, \pi\right]$$

$$10. \iint_R \frac{\ln(4xy)}{xy} \, dA \quad R = [1, 2] \times [3, 4]$$

$$11. \iint_R x^2 y^3 e^{x^3 - y^4} \, dA \quad R = [0, 1] \times [-1, 0]$$

$$12. \iint_R 42yx^3(1+x^2y^2)^6 dA \quad R = [0, 1] \times [0, 2]$$

$$13. \iint_R \frac{\cos\left(\frac{x}{y}\right)}{y^3} dA \quad R = \left[\frac{\pi}{2}, \pi\right] \times [1, 2]$$

$$14. \iint_R \frac{x \cos\left(\frac{x}{y}\right)}{y^2} dA \quad R = \left[\frac{\pi}{2}, \pi\right] \times [1, 2]$$

$$15. \iint_R 2y \ln(x) - 20x^3y^3 dA \quad R = [1, 2] \times [0, 4]$$

$$16. \iint_R xy e^x \cos(y) dA \quad R = [0, 1] \times [0, \pi]$$

17. Determine the volume that lies under $f(x, y) = 20 - 3x^3 - 3y^2$ and above the rectangle given by $[-2, 2] \times [-1, 1]$ in the xy -plane.

18. Determine the volume that lies under $f(x, y) = 10 + xy \sin(x^2 - y^2)$ and above the rectangle given by $[-3, 0] \times [1, 3]$ in the xy -plane.

15.3 Double Integrals over General Regions

1. Evaluate $\iint_D 8yx^3 dA$ where $D = \{(x, y) \mid -1 \leq y \leq 2, -1 \leq x \leq 1 + y^2\}$
2. Evaluate $\iint_D 12x^2y - y^2 dA$ where $D = \{(x, y) \mid -2 \leq x \leq 2, -x^2 \leq y \leq x^2\}$
3. Evaluate $\iint_D 9 - \frac{6y^2}{x^2} dA$ where D is the region in the 1st quadrant bounded by $y = x^3$ and $y = 4x$.
4. Evaluate $\iint_D 15x^2 - 6y dA$ where D is the region bounded by $x = \frac{1}{2}y^2$ and $x = 4\sqrt{y}$.
5. Evaluate $\iint_D 6y(x + 6)^2 dA$ where D is the region bounded by $x = -y^2$ and $x = y - 6$.
6. Evaluate $\iint_D e^{y^2+1} dA$ where D is the triangle with vertices $(0, 0)$, $(-2, 4)$ and $(8, 4)$.
7. Evaluate $\iint_D 7y^3 e^{x^2+1} dA$ where D is the region bounded by $y = 2\sqrt[4]{x}$, $x = 9$ and the x -axis.
8. Evaluate $\iint_D x^5 \sin(y^4) dA$ where D is the region in the 2nd quadrant bounded by $y = 3x^2$, $y = 12$ and the y -axis.
9. Evaluate $\iint_D xy - y^2 dA$ where D is the region shown below.

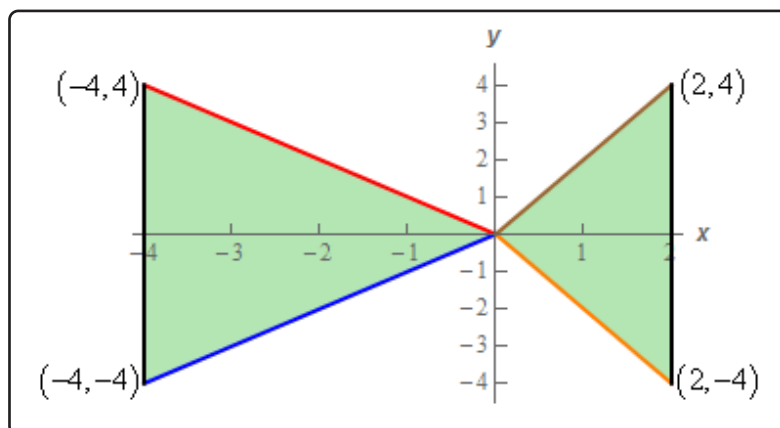

10. Evaluate $\iint_D 12x^3 - 3 \, dA$ where D is the region shown below.

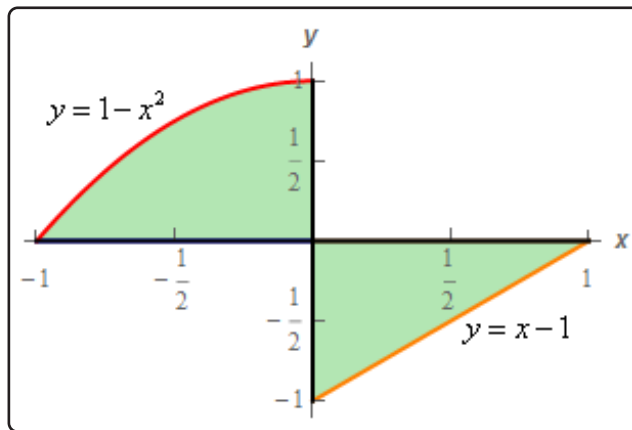

11. Evaluate $\iint_D 6y^2 + 10yx^4 \, dA$ where D is the region shown below.

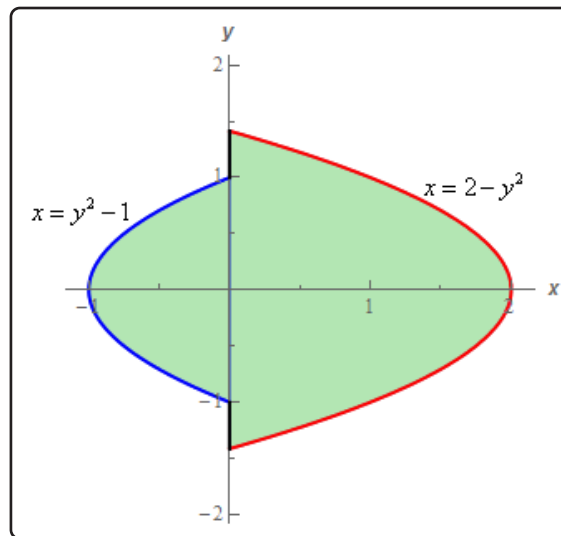

12. Evaluate $\iint_D \frac{x^3}{y^2} \, dA$ where D is the region bounded by $y = \frac{1}{x^2}$, $x = 1$ and $y = \frac{1}{4}$ in the order given below.

(a) Integrate with respect to x first and then y .

(b) Integrate with respect to y first and then x .

13. Evaluate $\iint_D xy - y^3 dA$ where D is the region bounded by $y = x^2$, $y = -x^2$ and $x = 2$ in the order given below.
- (a) Integrate with respect to x first and then y .
- (b) Integrate with respect to y first and then x .

For problems 14 - 16 evaluate the given integral by first reversing the order of integration.

14. $\int_0^8 \int_{y^{\frac{1}{3}}}^2 \frac{y}{x^7 + 1} dx dy$

15. $\int_{-4}^0 \int_{\sqrt{-x}}^2 x^{-\frac{2}{3}} \sqrt{y^{\frac{5}{3}} + 1} dy dx$

16. $\int_0^2 \int_{-x}^{3x} 5y^2x^3 + 2 dy dx$

17. Use a double integral to determine the area of the region bounded by $x = -y^2$ and $x = y - 6$.
18. Use a double integral to determine the area of the region bounded by $y = x^2 + 1$ and $y = \frac{1}{2}x^2 + 3$.
19. Use a double integral to determine the volume of the region that is between the xy -plane and $f(x, y) = 2 - xy^2$ and is above the region in the xy -plane that is bounded by $y = x^2$ and $x = 1$.
20. Use a double integral to determine the volume of the region that is between the xy -plane and $f(x, y) = 1 + y^5 \sqrt{x^4 + 1}$ and is above the region in the xy -plane that is bounded by $y = \sqrt{x}$, $x = 2$ and the x -axis.
21. Use a double integral to determine the volume of the region in the first octant that is below the plane given by $2x + 6y + 4z = 8$.
22. Use a double integral to determine the volume of the region bounded by $z = 3 - 2y$, the surface $y = 1 - x^2$ and the planes $y = 0$ and $z = 0$.
23. Use a double integral to determine the volume of the region bounded by the planes $z = 4 - 2x - 2y$, $y = 2x$, $y = 0$ and $z = 0$.
24. Use a double integral to determine the formula for the area of a right triangle with base, b and height h .

25. Use a double integral to determine a formula for the figure below.

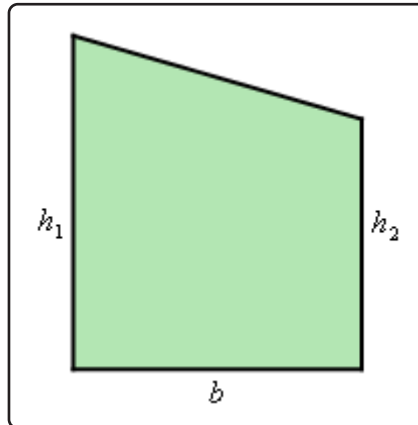

15.4 Double Integrals in Polar Coordinates

1. Evaluate $\iint_D 3xy^2 - 2 \, dA$ where D is the unit circle centered at the origin.
2. Evaluate $\iint_D 4x - 2y \, dA$ where D is the top half of region between $x^2 + y^2 = 4$ and $x^2 + y^2 = 25$.
3. Evaluate $\iint_D 6xy + 4x^2 \, dA$ where D is the portion of $x^2 + y^2 = 9$ in the 2nd quadrant.
4. Evaluate $\iint_D \sin(3x^2 + 3y^2) \, dA$ where D is the region between $x^2 + y^2 = 1$ and $x^2 + y^2 = 7$.
5. Evaluate $\iint_D e^{1-x^2-y^2} \, dA$ where D is the region in the 4th quadrant between $x^2 + y^2 = 16$ and $x^2 + y^2 = 36$.
6. Use a double integral to determine the area of the region that is inside $r = 6 - 4 \cos(\theta)$.
7. Use a double integral to determine the area of the region that is inside $r = 4$ and outside $r = 8 + 6 \sin(\theta)$.
8. Evaluate the following integral by first converting to an integral in polar coordinates.

$$\int_{-2}^0 \int_{-\sqrt{4-y^2}}^{\sqrt{4-y^2}} x^2 \, dx \, dy$$

9. Evaluate the following integral by first converting to an integral in polar coordinates.

$$\int_{-1}^1 \int_0^{\sqrt{1-x^2}} \sqrt{x^2 + y^2} \, dy \, dx$$

10. Use a double integral to determine the volume of the solid that is below $z = 9 - 4x^2 - 4y^2$ and above the xy -plane.
11. Use a double integral to determine the volume of the solid that is bounded by $z = 12 - 3x^2 - 3y^2$ and $z = x^2 + y^2 - 8$.
12. Use a double integral to determine the volume of the solid that is inside both the cylinder $x^2 + y^2 = 9$ and the sphere $x^2 + y^2 + z^2 = 16$.
13. Use a double integral to derive the area of a circle of radius a .

14. Use a double integral to derive the area of the region between circles of radius a and b with $\alpha \leq \theta \leq \beta$. See the image below for a sketch of the region.

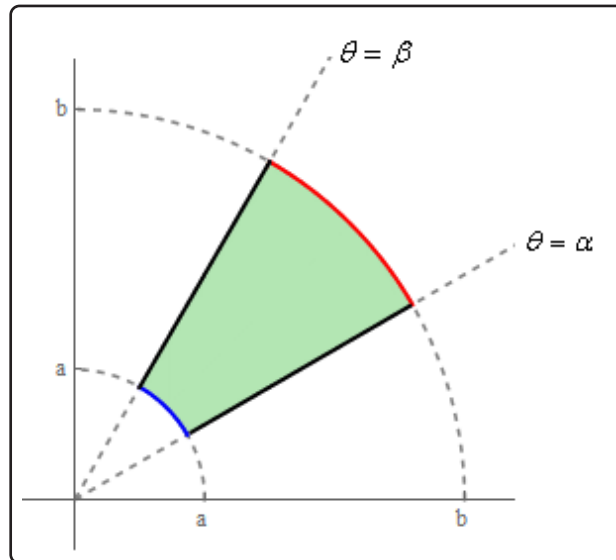

15.5 Triple Integrals

1. Evaluate $\int_1^2 \int_0^2 \int_{-1}^1 2 + z^2 - xy \, dz \, dx \, dy$
2. Evaluate $\int_2^0 \int_{x^2}^1 \int_0^{xz} y^2 - 6z \, dy \, dz \, dx$
3. Evaluate $\int_{-1}^2 \int_0^1 \int_0^{2z} 3x - \sqrt{1 + z^2} \, dx \, dz \, dy$
4. Evaluate $\iiint_E 12y \, dV$ where E is the region below $6x + 4y + 3z = 12$ in the first octant.
5. Evaluate $\iiint_E 5x^2 \, dV$ where E is the region below $x + 2y + 4z = 8$ in the first octant.
6. Evaluate $\iiint_E 10z^2 - x \, dV$ where E is the region below $z = 8 - y$ and above the region in the xy -plane bounded by $y = 2x$, $x = 3$ and $y = 0$.
7. Evaluate $\iiint_E 4y^2 \, dV$ where E is the region below $z = -3x^2 - 3y^2$ and above $z = -12$.
8. Evaluate $\iiint_E 2y - 9z \, dV$ where E is the region behind $6x + 3y + 3z = 15$ front of the triangle in the xy -plane with vertices, in (x, z) form $:(0, 0)$, $(0, 4)$ and $(2, 4)$.
9. Evaluate $\iiint_E 18x \, dV$ where E is the region behind the surface $y = 4 - x^2$ that is in front of the region in the xz -plane bounded by $z = -3x$, $z = 2x$ and $z = 2$.
10. Evaluate $\iiint_E 20x^3 \, dV$ where E is the region bounded by $x = 2 - y^2 - z^2$ and $x = 5y^2 + 5z^2 - 6$.
11. Evaluate $\iiint_E 6z^2 \, dV$ where E is the region behind $x + 6y + 2z = 8$ that is in front of the region in the xy -plane bounded by $z = 2y$ and $z = \sqrt{4y}$.
12. Evaluate $\iiint_E 8y \, dV$ where E is the region between $x + y + z = 6$ and $x + y + z = 10$ above the triangle in the xy -plane with vertices, in (x, y) form $:(0, 0)$, $(1, 2)$ and $(1, 4)$.

13. Evaluate $\iiint_E 8y \, dV$ where E is the region between $x + y + z = 6$ and $x + y + z = 10$ in front of the triangle in the xy -plane with vertices, in (x, z) form : $(0, 0)$, $(1, 2)$ and $(1, 4)$.
14. Evaluate $\iiint_E 8y \, dV$ where E is the region between $x + y + z = 6$ and $x + y + z = 10$ in front of the triangle in the xy -plane with vertices, in (y, z) form : $(0, 0)$, $(1, 2)$ and $(1, 4)$.
15. Use a triple integral to determine the volume of the region below $z = 8 - y$ and above the region in the xy -plane bounded by $y = 2x$, $x = 3$ and $y = 0$.
16. Use a triple integral to determine the volume of the region in the 1st octant that is below $4x + 8y + z = 16$.
17. Use a triple integral to determine the volume of the region behind $6x + 3y + 3z = 15$ front of the triangle in the xz -plane with vertices, in (x, z) form : $(0, 0)$, $(0, 4)$ and $(2, 4)$.
18. Use a triple integral to determine the volume of the region bounded by $y = x^2 + z^2$ and $y = \sqrt{x^2 + z^2}$.
19. Use a triple integral to determine the volume of the region behind $x + 6y + 2z = 8$ that is in front of the region in the xy -plane bounded by $z = 2y$ and $z = \sqrt{4y}$.

15.6 Triple Integrals in Cylindrical Coordinates

1. Evaluate $\iiint_E 8z \, dV$ where E is the region bounded by $z = 2x^2 + 2y^2 - 4$ and $z = 5 - x^2 - y^2$ in the 1st octant.
2. Evaluate $\iiint_E 6xy \, dV$ where E is the region above $z = 2x - 10$, below $z = 2$ and inside the cylinder $x^2 + y^2 = 4$.
3. Evaluate $\iiint_E 9yz^3 \, dV$ where E is the region between $x = -\sqrt{9y^2 + 9z^2}$ and $x = \sqrt{y^2 + z^2}$ inside the cylinder $y^2 + z^2 = 1$.
4. Evaluate $\iiint_E x + 2 \, dV$ where E is the region bounded by $x = 18 - 4y^2 - 4z^2$ and $x = 2$ with $z \geq 0$.
5. Evaluate $\iiint_E x + 2 \, dV$ where E is the region between the two planes $2x + y + z = 6$ and $6x + 3y + 3z = 12$ inside the cylinder $x^2 + z^2 = 16$.
6. Evaluate $\iiint_E x^2 \, dV$ where E is the region bounded by $y = x^2 + z^2 - 4$ and $y = 8 - 5x^2 - 5z^2$ with $x \leq 0$.
7. Use a triple integral to determine the volume of the region bounded by $z = \sqrt{x^2 + y^2}$, and $z = x^2 + y^2$ in the 1st octant.
8. Use a triple integral to determine the volume of the region bounded by $y = \sqrt{9x^2 + 9z^2}$, and $y = -3x^2 - 3z^2$ in the 1st octant.
9. Use a triple integral to determine the volume of the region behind $x = z + 3$, in front of $x = -z - 6$ and inside the cylinder $y^2 + z^2 = 4$.
10. Evaluate the following integral by first converting to an integral in cylindrical coordinates.

$$\int_{-4}^4 \int_0^{\sqrt{16-y^2}} \int_0^{6+x} 6yx^2 \, dz \, dx \, dy$$

11. Evaluate the following integral by first converting to an integral in cylindrical coordinates.

$$\int_0^3 \int_{-\sqrt{9-x^2}}^{\sqrt{9-x^2}} \int_{-\sqrt{2x^2+2y^2}}^{6+x^2+y^2} 15z \, dz \, dy \, dx$$

12. Use a triple integral in cylindrical coordinates to derive the volume of a cylinder of height h and radius a .

15.7 Triple Integrals in Spherical Coordinates

1. Evaluate $\iiint_E 4y^2 dV$ where E is the sphere $x^2 + y^2 + z^2 = 9$.
2. Evaluate $\iiint_E 3x - 2y dV$ where E is the region between the spheres $x^2 + y^2 + z^2 = 1$ and $x^2 + y^2 + z^2 = 4$ with $z \leq 0$.
3. Evaluate $\iiint_E 2yz dV$ where E is the region inside both $x^2 + y^2 + z^2 = 16$ and $z = \sqrt{3x^2 + 3y^2}$ that is in the 1st octant.
4. Evaluate $\iiint_E z^2 dV$ where E is the region between the spheres $x^2 + y^2 + z^2 = 4$ and $x^2 + y^2 + z^2 = 25$ and inside $z = -\sqrt{\frac{1}{3}x^2 + \frac{1}{3}y^2}$.
5. Evaluate $\iiint_E 5y^2 dV$ where E is the portion of $x^2 + y^2 + z^2 = 4$ with $x \leq 0$.
6. Evaluate $\iiint_E 2 + 16x dV$ where E is the region between the spheres $x^2 + y^2 + z^2 = 1$ and $x^2 + y^2 + z^2 = 4$ with $y \geq 0$ and $z \leq 0$.
7. Evaluate the following integral by first converting to an integral in cylindrical coordinates.

$$\int_0^2 \int_{-\sqrt{4-x^2}}^0 \int_{\sqrt{5x^2+5y^2}}^{\sqrt{9-x^2-y^2}} 7x dz dy dx$$

8. Evaluate the following integral by first converting to an integral in cylindrical coordinates.

$$\int_{-\sqrt{5}}^{\sqrt{5}} \int_0^{\sqrt{5-y^2}} \int_{-\sqrt{10-x^2-y^2}}^{-\sqrt{x^2+y^2}} 3xz^2 dz dx dy$$

9. Use a triple integral in spherical coordinates to derive the volume of a sphere with radius a .

15.8 Change of Variables

For problems 1 - 4 compute the Jacobian of each transformation.

1. $x = 4u^2v$ $y = 6v - 7u$

2. $x = \sqrt{u}$ $y = 10u + v$

3. $x = v^3u$ $y = \frac{u^2}{v}$

4. $x = e^u \cos(v)$ $y = e^u \sin(v)$

5. If R is the region inside the ellipse $\frac{x^2}{25} + 49y^2 = 1$ determine the region we would get applying the transformation $x = 5u$, $y = \frac{1}{7}v$ to R .

6. If R is the triangle with vertices $(2, 0)$, $(6, 4)$ and $(1, 4)$ determine the region we would get applying the transformation $x = \frac{1}{5}(u - v)$, $y = \frac{1}{5}(u + 4v)$ to R .

7. If R is the parallelogram with vertices $(0, 0)$, $(4, 2)$, $(0, 4)$ and $(-4, 2)$ determine the region we would get applying the transformation $x = u - v$, $y = \frac{1}{2}(u + v)$ to R .

8. If R is the square defined by $0 \leq x \leq 3$ and $0 \leq y \leq 3$ determine the region we would get applying the transformation $x = 3u$, $y = v(2 + u^2)$ to R .

9. If R is the parallelogram with vertices $(1, 1)$, $(5, 3)$, $(8, 8)$ and $(4, 6)$ determine the region we would get applying the transformation $x = \frac{6}{7}(u - v)$, $y = \frac{1}{7}(10u - 3v)$ to R .

10. If R is the region bounded by $xy = 4$, $xy = 10$, $y = x$ and $y = 6x$ determine the region we would get applying the transformation $x = 2\sqrt{\frac{u}{v}}$, $y = 4\sqrt{uv}$ to R .

11. Evaluate $\iint_R x^2 y^4 dA$ where R is the region bounded by $xy = 4$, $xy = 10$, $y = x$ and $y = 6x$ using the transformation $x = 2\sqrt{\frac{u}{v}}$, $y = 4\sqrt{uv}$.

12. Evaluate $\iint_R 1 - y dA$ where R is the triangle with vertices $(0, 4)$, $(1, 1)$ and $(2, 5)$ using the transformation $x = \frac{1}{7}(7 + u - v)$, $y = \frac{1}{7}(7 + 4u + 3v)$ to R .

13. Evaluate $\iint_R 121x \, dA$ where R is the parallelogram with vertices $(0, 0)$, $(6, 2)$, $(7, 6)$ and $(1, 4)$ using the transformation $x = \frac{1}{11}(v - 3u)$, $y = \frac{1}{11}(4v - u)$ to R .
14. Evaluate $\iint_R \frac{15y}{x} \, dA$ where R is the region bounded by $xy = 2$, $xy = 6$, $y = 4$ and $y = 10$ using the transformation $x = v$, $y = \frac{2u}{3v}$.
15. Evaluate $\iint_R 2y - 8x \, dA$ where R is the parallelogram with vertices $(6, 0)$, $(8, 4)$, $(6, 8)$ and $(4, 4)$ using the transformation $x = \frac{1}{4}(u - v)$, $y = \frac{1}{2}(u + v)$ to R .
16. Derive a transformation that will transform the ellipse $\frac{x^2}{a^2} + \frac{y^2}{b^2} = 1$ into a unit circle.
17. Derive the transformation used in problem 12.
18. Derive the transformation used in problem 13.
19. Derive a transformation that will convert the parallelogram with vertices $(4, 1)$, $(7, 4)$, $(6, 8)$ and $(3, 5)$ into a rectangle in the uv system.
20. Derive a transformation that will convert the parallelogram with vertices $(4, 1)$, $(7, 4)$, $(6, 8)$ and $(3, 5)$ into a rectangle with one corner occurring at the origin of the uv system.

15.9 Surface Area

1. Determine the surface area of the portion of $6x + y + 2z = 10$ that is in the 1st octant.
2. Determine the surface area of the portion of $4x + 3y + 5z = 8$ that is inside the cylinder $x^2 + y^2 = 49$.
3. Determine the surface area of the portion of $z = 9x^2 + 9y^2 - 1$ that is below the xy -plane with $x \leq 0$.
4. Determine the surface area of the portion of $z = 6y + 2x^2$ that is above the triangle in the xy -plane with vertices $(0, 0)$, $(8, 0)$ and $(8, 2)$.
5. Determine the surface area of the portion of $y = 8z + 2x^3 + 1$ that is in front of the region in the xz -plane bounded by $z = x^3$, $x = 2$ and the x -axis.
6. Determine the surface area of the portion of $x = 6 - y^2 - z^2$ that is in front of $x = 2$ with $y \geq 0$.
7. Determine the surface area of the portion of $y = 4x + 3z^2$ that is in front of the triangle in the xz -plane with vertices $(0, 0)$, $(2, 6)$ and $(0, 6)$.
8. Determine the surface area of the portion of $y = 3x^2 + 3z^2$ that is inside the cylinder $x^2 + z^2 = 1$.
9. Determine the surface area of the portion of the sphere of radius 4 that is inside the cylinder $x^2 + y^2 = 3$.

15.10 Area and Volume Revisited

The intent of the section was just to recap the various area and volume formulas from this chapter and so no problems have been (or likely will be in the near future) written.

16 Line Integrals

We now need to move on to a new kind of integral. When doing single variable definite integrals we integrated a function of one variable over an interval. In the last chapter we integrated a function of two variables over a two dimensional region and we integrated a function of three variables over a three dimensional solid. In this chapter we are going to look at Line Integrals. The difference in this chapter versus the last chapter is where the values of the variables will come from. For a line integral of a function of two variables the variables will all be on the graph of a two dimensional curve C . Similarly, for a line integral of a function of three variables, the variables will all be on the graph of a three dimensional curve C .

The other main difference in this chapter versus previous chapters in which we evaluated integrals is that in addition to evaluating line integrals over functions we will also, for the first time, be integrating a vector field (which we'll also define).

Once we have a grasp on line integrals and how to compute them we'll take a look at the Fundamental Theorem of Calculus for Line Integrals and it's relationship with conservative vector fields. We will, in addition, discuss a method for determining if a two dimensional vector field is conservative or not and if it is conservative how to find the potential function for the vector field.

Finally, we'll discuss a very important theorem, Green's Theorem. Green's theorem gives a very important relationship between certain line integrals and double integrals.

If you are looking for some practice problems (with solutions available) please check out the [Practice Problems](#). There you will find a set of problems that should give you quite a bit practice.

16.1 Vector Fields

1. Sketch the vector field for $\vec{F} = -y^2 \vec{i} + x \vec{j}$.
2. Sketch the vector field for $\vec{F} = \vec{i} + xy \vec{j}$.
3. Sketch the vector field for $\vec{F} = 4y \vec{i} + (x + 2) \vec{j}$.
4. Compute the gradient vector field for $f(x, y) = 6x^2 - 9y + x^3 \sqrt{y}$.
5. Compute the gradient vector field for $f(x, y) = \sin(2x) \cos(3x)$.
6. Compute the gradient vector field for $f(x, y, z) = z e^{xy} + y^3 \tan(4x)$.
7. Compute the gradient vector field for $f(x, y, z) = x y^2 z^3 + 4x e^{y^2} - \ln(x - z)$.

16.2 Line Integrals - Part I

For problems 1 - 10 evaluate the given line integral. Follow the direction of C as given in the problem statement.

1. Evaluate $\int_C 3y \, ds$ where C is the portion of $x = 9 - y^2$ from $y = -1$ and $y = 2$.
2. Evaluate $\int_C \sqrt{x} + 2xy \, ds$ where C is the line segment from $(7, 3)$ to $(0, 6)$.
3. Evaluate $\int_C y^2 - 10xy \, ds$ where C is the left half of the circle centered at the origin of radius 6 with counter clockwise rotation.
4. Evaluate $\int_C x^2 - 2y \, ds$ where C is given by $\vec{r}(t) = \langle 4t^4, t^4 \rangle$ for $-1 \leq t \leq 0$.
5. Evaluate $\int_C z^3 - 4x + 2y \, ds$ where C is the line segment from $(2, 4, -1)$ to $(1, -1, 0)$.
6. Evaluate $\int_C x + 12xz \, ds$ where C is given by $\vec{r}(t) = \left\langle t, \frac{1}{2}t^2, \frac{1}{4}t^4 \right\rangle$ for $-2 \leq t \leq 1$.
7. Evaluate $\int_C z^3(x + 7) - 2y \, ds$ where C is the circle centered at the origin of radius 1 centered on the x -axis at $x = -3$. See the sketches below for the direction.

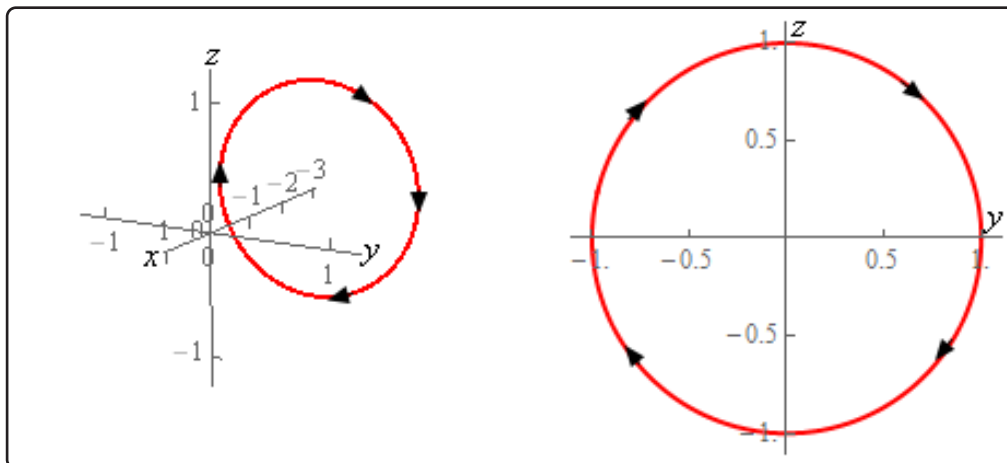

8. Evaluate $\int_C 6x \, ds$ where C is the portion of $y = 3 + x^2$ from $x = -2$ to $x = 0$ followed by the portion of $y = 3 - x^2$ from $x = 0$ to $x = 2$ which in turn is followed by the line segment from $(2, -1)$ to $(-1, -2)$. See the sketch below for the direction.

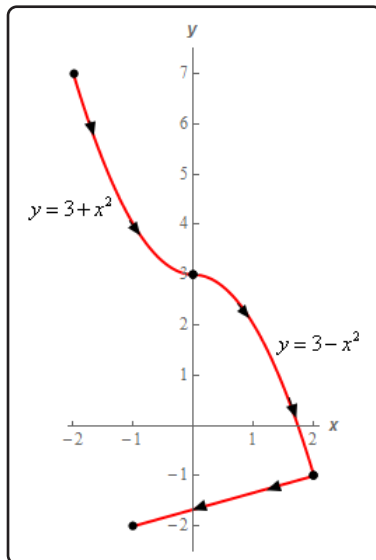

9. Evaluate $\int_C 2 - xy \, ds$ where C is the upper half of the circle centered at the origin of radius 1 with the clockwise rotation followed by the line segment from $(1, 0)$ to $(3, 0)$ which in turn is followed by the lower half of the circle centered at the origin of radius 3 with the clockwise rotation. See the sketch below for the direction.

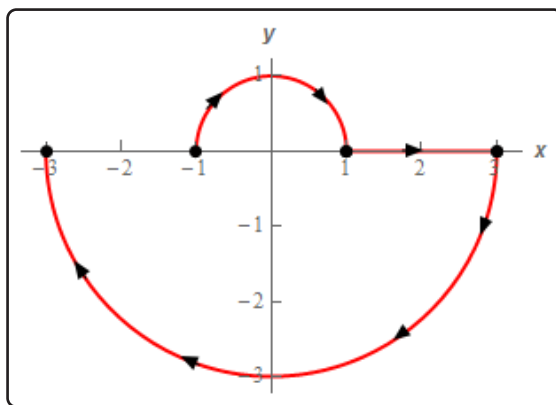

10. Evaluate $\int_C 3xy + (x - 1)^2 \, ds$ where C is the triangle with vertices $(0, 3)$, $(6, 0)$ and $(0, 0)$ with the clockwise rotation.

11. Evaluate $\int_C x^5 ds$ for each of the following curves.

(a) C is the line segment from $(-1, 3)$ to $(0, 0)$ followed by the line segment from $(0, 0)$ to $(0, 4)$.

(b) C is the portion of $y = 4 - x^4$ from $x = -1$ to $x = 0$.

12. Evaluate $\int_C 3x - 6y ds$ for each of the following curves.

(a) C is the line segment from $(6, 0)$ to $(0, 3)$ followed by the line segment from $(0, 3)$ to $(6, 6)$.

(b) C is the line segment from $(6, 0)$ to $(6, 6)$.

13. Evaluate $\int_C y^2 - 3z + 2 ds$ for each of the following curves.

(a) C is the line segment from $(1, 0, 4)$ to $(2, -1, 1)$.

(b) C is the line segment from $(2, -1, 1)$ to $(1, 0, 4)$.

16.3 Line Integrals - Part II

For problems 1 - 7 evaluate the given line integral. Follow the direction of C as given in the problem statement.

1. Evaluate $\int_C xy \, dx + (x - y) \, dy$ where C is the line segment from $(0, -3)$ to $(-4, 1)$.

2. Evaluate $\int_C e^{3x} \, dx$ where C is portion of $x = \sin(4y)$ from $y = \frac{\pi}{8}$ to $y = \pi$.

3. Evaluate $\int_C x \, dy - (x^2 + y) \, dx$ where C is portion of the circle centered at the origin of radius 3 in the 2nd quadrant with clockwise rotation.

4. Evaluate $\int_C dx - 3y^3 \, dy$ where C is given by $\vec{r}(t) = 4 \sin(\pi t) \vec{i} + (t - 1)^2 \vec{j}$ with $0 \leq t \leq 1$.

5. Evaluate $\int_C 4y^2 \, dx + 3x \, dy + 2z \, dz$ where C is the line segment from $(4, -1, 2)$ to $(1, 7, -1)$.

6. Evaluate $\int_C (yz + x) \, dx + yz \, dy - (y + z) \, dz$ where C is given by $\vec{r}(t) = 3t \vec{i} + 4 \sin(t) \vec{j} + 4 \cos(t) \vec{k}$ with $0 \leq t \leq \pi$.

7. Evaluate $\int_C 7xy \, dy$ where C is the portion of $y = \sqrt{x^2 + 5}$ from $x = -1$ to $x = 2$ followed by the line segment from $(2, 3)$ to $(4, -1)$. See the sketch below for the direction.

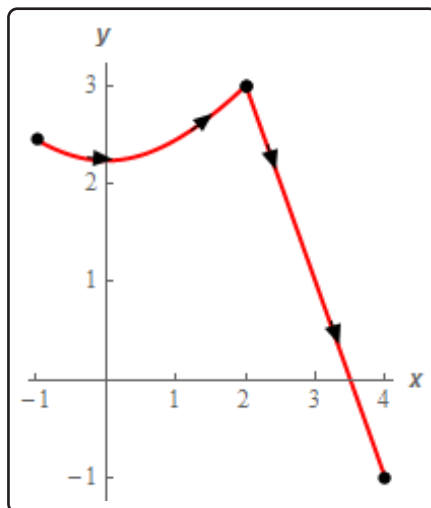

8. Evaluate $\int_C (y^2 - x) dx - 4y dy$ where C is the portion of $y = x^2$ from $x = -2$ to $x = 2$ followed by the line segment from $(2, 4)$ to $(0, 6)$ which in turn is followed by the line segment from $(0, 6)$ to $(-2, 4)$. See the sketch below for the direction.

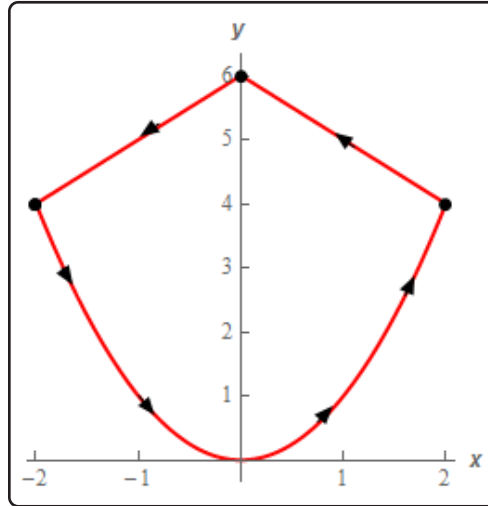

9. Evaluate $\int_C (x^2 - 2) dx + 7xy^2 dy$ for each of the following curves.
- C is the portion of $x = -y^2$ from $y = -1$ to $y = 1$.
 - C is the line segment from $(-1, -1)$ to $(1, 1)$.
10. Evaluate $\int_C x^3 + 9y dy$ for each of the following curves.
- C is the portion of $y = 1 - x^2$ from $x = -1$ to $x = 1$.
 - C is the line segment from $(-1, 0)$ to $(0, -1)$ followed by the line segment from $(0, -1)$ to $(1, 0)$.
11. Evaluate $\int_C xy^3 dx - 4x dy$ for each of the following curves.
- C is the portion of the circle centered at the origin of radius 7 in the 1st quadrant with counter clockwise rotation.
 - C is the portion of the circle centered at the origin of radius 7 in the 1st quadrant with clockwise rotation.

16.4 Line Integrals of Vector Fields

1. Evaluate $\int_C \vec{F} \cdot d\vec{r}$ where $\vec{F}(x, y) = 2x^2\vec{i} + (y^2 - 1)\vec{j}$ and C is the portion of $\frac{x^2}{25} + \frac{y^2}{9} = 1$ that is in the 1st, 4th and 3rd quadrant with the clockwise orientation.
2. Evaluate $\int_C \vec{F} \cdot d\vec{r}$ where $\vec{F}(x, y) = xy\vec{i} + (4x - 2y)\vec{j}$ and C is the line segment from $(4, -3)$ to $(7, 0)$.
3. Evaluate $\int_C \vec{F} \cdot d\vec{r}$ where $\vec{F}(x, y) = (x^3 - y)\vec{i} + (x^2 + 7x)\vec{j}$ and C is the portion of $y = x^3 + 2$ from $x = -1$ to $x = 2$.
4. Evaluate $\int_C \vec{F} \cdot d\vec{r}$ where $\vec{F}(x, y) = xy\vec{i} + (1 + x^2)\vec{j}$ and C is given by $\vec{r}(t) = e^{6t}\vec{i} + (4 - e^{2t})\vec{j}$ for $-2 \leq t \leq 0$.
5. Evaluate $\int_C \vec{F} \cdot d\vec{r}$ where $\vec{F}(x, y, z) = (3x - 3y)\vec{i} + (y^3 - 10)\vec{j} + yz\vec{k}$ and C is the line segment from $(1, 4, -2)$ to $(3, 4, 6)$.
6. Evaluate $\int_C \vec{F} \cdot d\vec{r}$ where $\vec{F}(x, y, z) = (x + z)\vec{i} + y^3\vec{j} + (1 - x)\vec{k}$ and C is the portion of the spiral on the y -axis given by $\vec{r}(t) = \cos(2t)\vec{i} - t\vec{j} + \sin(2t)\vec{k}$ for $-\pi \leq t \leq 2\pi$.
7. Evaluate $\int_C \vec{F} \cdot d\vec{r}$ where $\vec{F}(x, y) = x^2\vec{i} + (y^2 - x)\vec{j}$ and C is the line segment from $(2, 4)$ to $(0, 4)$ followed by the line segment from $(0, 4)$ to $(3, -1)$.
8. Evaluate $\int_C \vec{F} \cdot d\vec{r}$ where $\vec{F}(x, y) = xy\vec{i} - 3\vec{j}$ and C is the portion of $x^2 + \frac{y^2}{16} = 1$ in the 2nd quadrant with clockwise rotation followed by the line segment from $(0, 4)$ to $(4, -2)$. See the sketch on the next page.

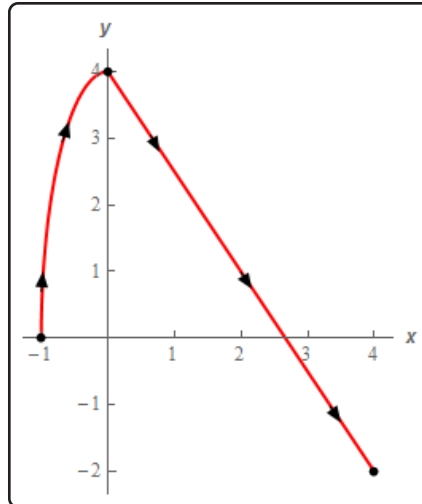

9. Evaluate $\int_C \vec{F} \cdot d\vec{r}$ where $\vec{F}(x, y) = xy^2 \vec{i} + (2y + 3x) \vec{j}$ and C is the portion of $x = y^2 - 1$ from $y = -2$ to $y = 2$ followed by the line segment from $(3, 2)$ to $(0, 0)$ which in turn is followed by the line segment from $(0, 0)$ to $(3, -2)$. See the sketch below.

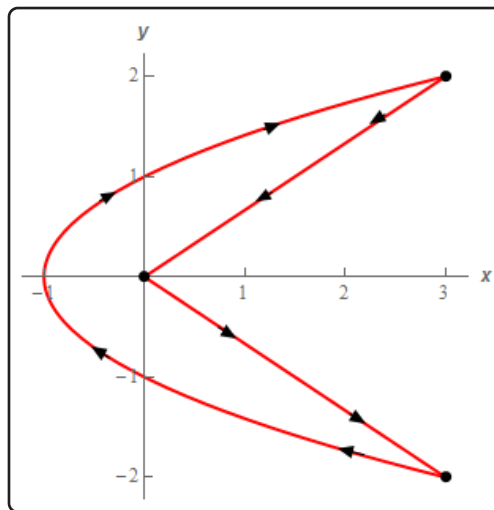

10. Evaluate $\int_C \vec{F} \cdot d\vec{r}$ where $\vec{F}(x, y) = (1 - y^2) \vec{i} - x \vec{j}$ for each of the following curves.
- C is the top half of the circle centered at the origin of radius 1 with the counter clockwise rotation.
 - C is the bottom half of $x^2 + \frac{y^2}{36} = 1$ with clockwise rotation.

11. Evaluate $\int_C \vec{F} \cdot d\vec{r}$ where $\vec{F}(x, y) = (x^2 + y + 2)\vec{i} + xy\vec{j}$ for each of the following curves.

(a) C is the portion of $y = x^2 - 2$ from $x = -3$ to $x = 3$.

(b) C is the line segment from $(-3, 5)$ to $(3, 5)$.

12. Evaluate $\int_C \vec{F} \cdot d\vec{r}$ where $\vec{F}(x, y) = y^2\vec{i} + (1 - 3x)\vec{j}$ for each of the following curves.

(a) C is the line segment from $(1, 4)$ to $(-2, 3)$.

(b) C is the line segment from $(-2, 3)$ to $(1, 4)$.

13. Evaluate $\int_C \vec{F} \cdot d\vec{r}$ where $\vec{F}(x, y) = -2x\vec{i} + (x + 2y)\vec{j}$ for each of the following curves.

(a) C is the portion of $\frac{x^2}{16} + \frac{y^2}{4} = 1$ in the 1st quadrant with counter clockwise rotation.

(b) C is the portion of $\frac{x^2}{16} + \frac{y^2}{4} = 1$ in the 1st quadrant with clockwise rotation.

16.5 Fundamental Theorem for Line Integrals

- Evaluate $\int_C \nabla f \cdot d\vec{r}$ where $f(x, y) = 5x - y^2 + 10xy + 9$ and C is given by $\vec{r}(t) = \left\langle \frac{2t}{t^2 + 1}, 1 - 8t \right\rangle$ with $-2 \leq t \leq 0$.
- Evaluate $\int_C \nabla f \cdot d\vec{r}$ where $f(x, y, z) = \frac{3x - 8y}{z - 6}$ and C is given by $\vec{r}(t) = 6t\vec{i} + 4\vec{j} + (9 - t^3)\vec{k}$ with $-1 \leq t \leq 3$.
- Evaluate $\int_C \nabla f \cdot d\vec{r}$ where $f(x, y) = 20y \cos(x + 3) - yx^3$ and C is right half of the ellipse given by $(x + 3)^2 + \frac{(y - 1)^2}{16} = 1$ with clockwise rotation.
- Compute $\int_C \vec{F} \cdot d\vec{r}$ where $\vec{F} = 2x\vec{i} + 4y\vec{j}$ and C is the circle centered at the origin of radius 5 with the counter clockwise rotation. Is $\int_C \vec{F} \cdot d\vec{r}$ independent of path? If it is not possible to determine if $\int_C \vec{F} \cdot d\vec{r}$ is independent of path clearly explain why not.
- Compute $\int_C \vec{F} \cdot d\vec{r}$ where $\vec{F} = y\vec{i} + x^2\vec{j}$ and C is the circle centered at the origin of radius 5 with the counter clockwise rotation. Is $\int_C \vec{F} \cdot d\vec{r}$ independent of path? If it is not possible to determine if $\int_C \vec{F} \cdot d\vec{r}$ is independent of path clearly explain why not.
- Evaluate $\int_C \nabla f \cdot d\vec{r}$ where $f(x, y, z) = zx^2 + x(y - 2)^2$ and C is the line segment from $(1, 2, 0)$ to $(-3, 10, 9)$ followed by the line segment from $(-3, 10, 9)$ to $(6, 0, 2)$.
- Evaluate $\int_C \nabla f \cdot d\vec{r}$ where $f(x, y) = 4x + 3xy^2 - \ln(x^2 + y^2)$ and C is the upper half of $x^2 + y^2 = 1$ with clockwise rotation followed by the right half of $(x - 1)^2 + \frac{(y - 2)^2}{4} = 1$ with counter clockwise rotation. See the sketch on the next page.

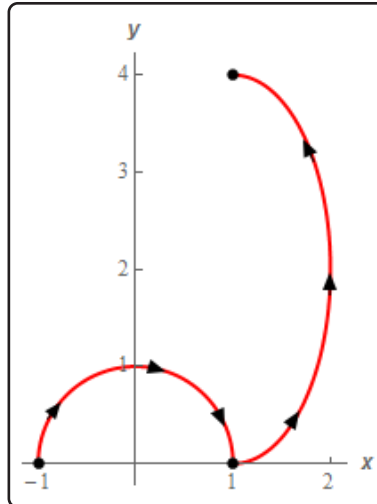

16.6 Conservative Vector Fields

For problems 1 - 4 determine if the vector field is conservative.

$$1. \vec{F} = (2xy^3 + e^x \cos(y)) \vec{i} + (e^x \sin(y) - 3x^2y^2) \vec{j}$$

$$2. \vec{F} = (xy^2 - 3y^4 + 2) \vec{i} + (xy^2 + x^2y^2 - x) \vec{j}$$

$$3. \vec{F} = (2 + 12xy^2 - 3x^2\sqrt{y}) \vec{i} - \left(\frac{x^3}{2\sqrt{y}} - 12x^2y \right) \vec{j}$$

$$4. \vec{F} = \left(8 - \frac{3x^2}{y} + 5x^4y^2 \right) \vec{i} + \left(6 + \frac{x^3}{y^2} - 3y^2 + 2x^5y \right) \vec{j}$$

For problems 5 - 11 find the potential function for the vector field.

$$5. \vec{F} = \left(4x^3 + 3y + \frac{2y^3}{x^3} \right) \vec{i} + \left(3x - 3y^2 - \frac{3y^2}{x^2} \right) \vec{j}$$

$$6. \vec{F} = (3x^2e^{2y} + 4ye^{4x}) \vec{i} - (7 - 2x^3e^{2y} - e^{4x}) \vec{j}$$

$$7. \vec{F} = (\cos(x) \cos(x+y) - 2y^2 - \sin(x) \sin(x+y)) \vec{i} - (4xy + \sin(x) \sin(x+y)) \vec{j}$$

$$8. \vec{F} = \left(\frac{4}{x^2} + \frac{2x}{y} + \frac{2}{x^2y^3} \right) \vec{i} + \left(\frac{6}{xy^4} - \frac{1+x^2}{y^2} \right) \vec{j}$$

$$9. \vec{F} = (2xe^{x^2-z} \sin(y^2) - 3y^3) \vec{i} + (2ye^{x^2-z} \cos(y^2) - 9xy^2) \vec{j} + (12z - e^{x^2-z} \sin(y^2)) \vec{k}$$

$$10. \vec{F} = (12x - 5z^2) \vec{i} + \ln(1+z^2) \vec{j} - \left(10xz - \frac{2yz}{1+z^2} \right) \vec{k}$$

$$11. \vec{F} = (zy^2e^{y-x} - xy^2ze^{y-x}) \vec{i} + (2xyz e^{y-x} + xy^2ze^{y-x}) \vec{j} + (xy^2e^{y-x} - 24z) \vec{k}$$

12. Evaluate $\int_C \vec{F} \cdot d\vec{r}$ where $\vec{F}(x, y) = \left(\frac{3x^2}{y-1} - 3x^2y \right) \vec{i} + \left(8y - x^3 - \frac{x^3}{(y-1)^2} \right) \vec{j}$ and C is the line segment from (1, 2) to (4, 3).

13. Evaluate $\int_C \vec{F} \cdot d\vec{r}$ where $\vec{F}(x, y) = (y^2 - 4y + 5) \vec{i} + (2xy - 4x - 9) \vec{j}$ and C the upper half of $\frac{x^2}{36} + \frac{y^2}{16} = 1$ with clockwise rotation.

14. Evaluate $\int_C \vec{F} \cdot d\vec{r}$ where $\vec{F}(x, y) = -(3 - (1+2y)e^{x-1}) \vec{i} + (3y^2 + 2e^{x-1}) \vec{j}$ and C is the portion of $y = x^3 + 1$ from $x = -2$ to $x = 1$.

15. Evaluate $\int_C \vec{F} \cdot d\vec{r}$ where $\vec{F}(x, y, z) = \frac{x}{\sqrt{x^2 + z^2}} \vec{i} + (2yz - 6y) \vec{j} + \left(y^2 + \frac{z}{\sqrt{x^2 + z^2}}\right) \vec{k}$ and C is the line segment from $(1, 0, -1)$ to $(2, -4, 3)$.
16. Evaluate $\int_C \vec{F} \cdot d\vec{r}$ where $\vec{F}(x, y, z) = (12xy - 2x) \vec{i} + (6x^2 - 8yz) \vec{j} + (8 - 4y^2) \vec{k}$ and C is the spiral given by $\vec{r}(t) = \langle \sin(\pi t), \cos(\pi t), 3t \rangle$ for $0 \leq t \leq 6$.
17. Evaluate $\int_C \vec{F} \cdot d\vec{r}$ where $\vec{F}(x, y) = (8 - 14xy^2 + 2ye^{2x}) \vec{i} + (e^{2x} - 14x^2y) \vec{j}$ and C is the curve shown below.

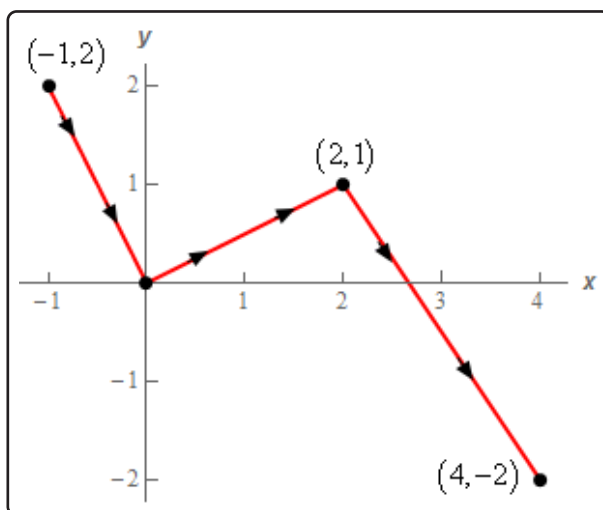

18. Evaluate $\int_C \vec{F} \cdot d\vec{r}$ where $\vec{F}(x, y) = (6x - 5y^2 + 2xy^3 - 10) \vec{i} + (3x^2y^2 - 10xy) \vec{j}$ and C is the curve shown below.

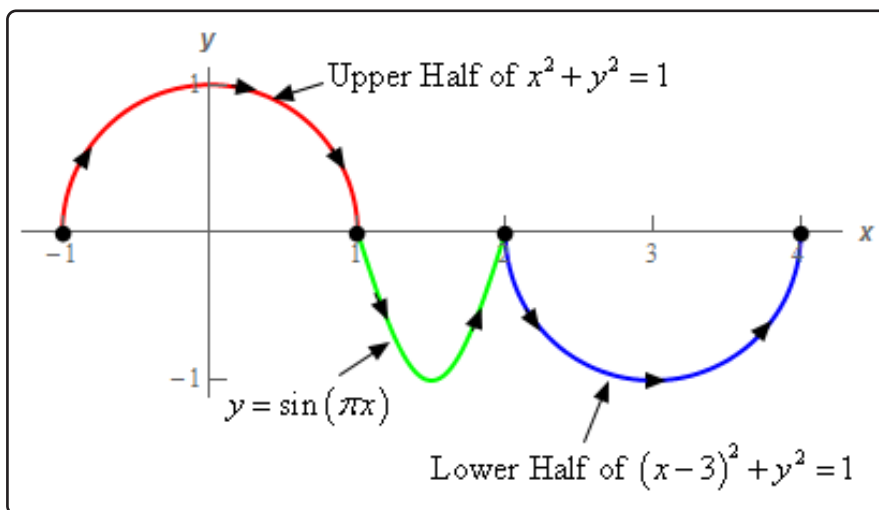

16.7 Green's Theorem

1. Use Green's Theorem to evaluate $\int_C (yx^2 - y) dx + (x^3 + 4) dy$ where C is shown below.

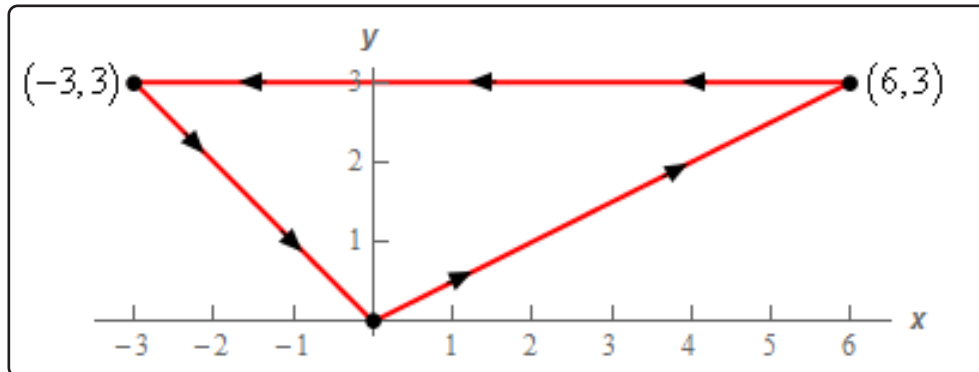

2. Use Green's Theorem to evaluate $\int_C (7x + y^2) dy - (x^2 - 2y) dx$ where C is are the two circles as shown below.

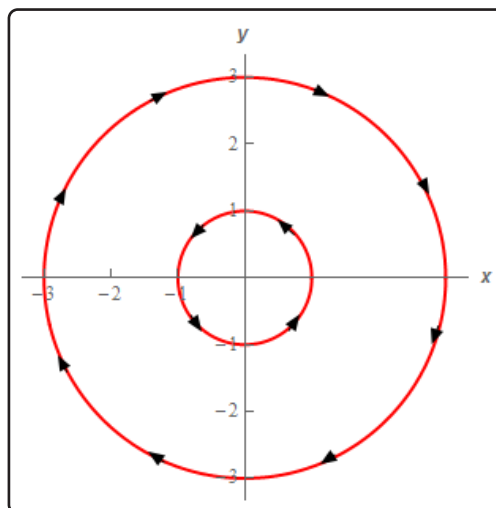

3. Use Green's Theorem to evaluate $\int_C (y^2 - 6y) dx + (y^3 + 10y^2) dy$ where C is shown below.

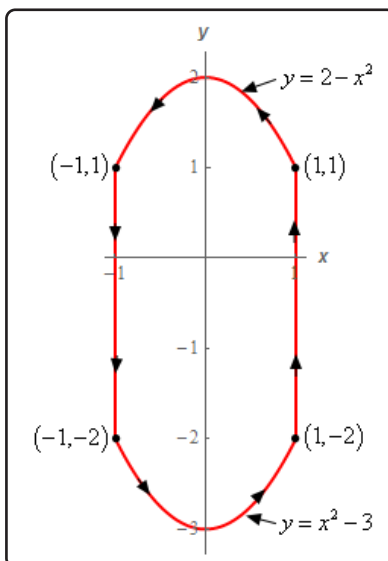

4. Use Green's Theorem to evaluate $\int_C xy^2 dx + (1 - xy^3) dy$ where C is shown below.

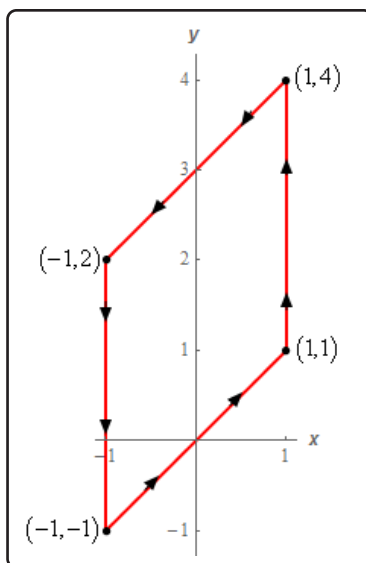

5. Use Green's Theorem to evaluate $\oint_C (y^2 - 4x) dx - (2 + x^2y^2) dy$ where C is shown below.

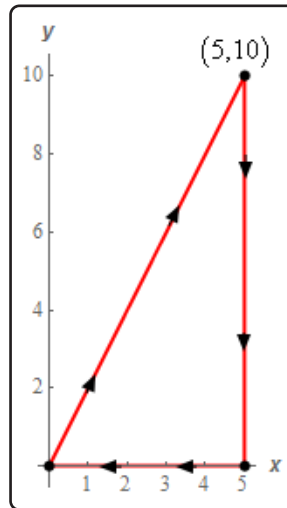

6. Use Green's Theorem to evaluate $\oint_C (y^3 - xy^2) dx + (2 - x^3) dy$ where C is shown below.

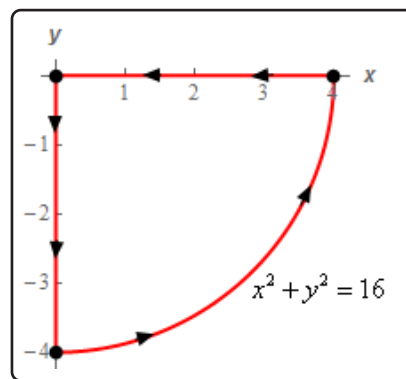

7. Verify Green's Theorem for $\oint_C (6 + x^2) dx + (1 - 2xy) dy$ where C is shown below by
(a) computing the line integral directly and **(b)** using Green's Theorem to compute the line integral.

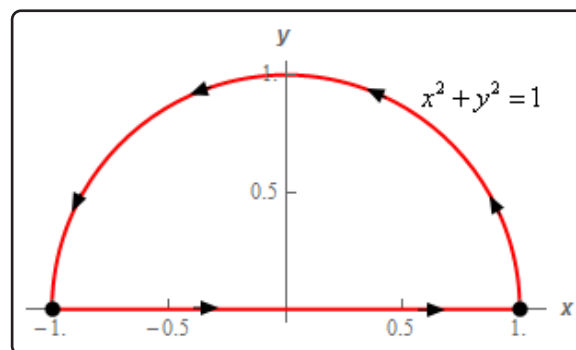

8. Verify Green's Theorem for $\oint_C (6y - 3y^2 + x) dx + yx^3 dy$ where C is shown below by **(a)** computing the line integral directly and **(b)** using Green's Theorem to compute the line integral.

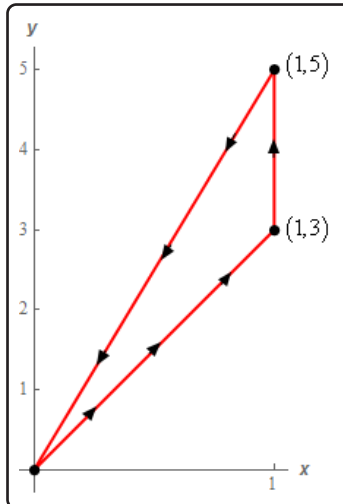

17 Surface Integrals

In this chapter we are going to take a look at surface integrals. In the previous chapter we integrated a line integral of a function of three variables where the variables came from a three dimensional curve. In this chapter we want to integrate a function of three variables but now the variables will come from a three dimensional solid. As with line integrals we will integrate both functions and vector fields.

We will also introduce the concept of the curl and divergence of a vector field. In addition, we will discuss how to write down a set of parametric equations for a surface.

We will close out the chapter by discussing Stokes' Theorem and the Divergence Theorem. Stokes' Theorem will give a nice relationship between line integrals and surface integrals. The Divergence Theorem will give a relationship between surface integrals and triple integrals.

If you are looking for some practice problems (with solutions available) please check out the [Practice Problems](#). There you will find a set of problems that should give you quite a bit practice.

17.1 Curl and Divergence

For problems 1 - 3 compute $\text{div}\vec{F}$ and $\text{curl}\vec{F}$.

1. $\vec{F} = (2y - \cos(x))\vec{i} - z^2\mathbf{e}^{3x}\vec{j} + (x^2 - 7z)\vec{k}$

2. $\vec{F} = -(4y - 1)\vec{i} + xy^2\vec{j} + (x - 3y)\vec{k}$

3. $\vec{F} = z^2(y - x)\vec{i} + \frac{4y^2}{z^3}\vec{j} + (x^2 - 3z)\vec{k}$

For problems 4 - 6 determine if the vector field is conservative.

4. $\vec{F} = (2xy^2 - 16x)\vec{i} + 2y(x^2 - 1)\vec{j} + 9\vec{k}$

5. $\vec{F} = (y - 3z)\vec{i} + (x^2 + y^4)\vec{j} - 4z^2\vec{k}$

6. $\vec{F} = (18x^2 + 4z^3)\vec{i} - 12yz\vec{j} - (6y^2 - 12xz^2)\vec{k}$

17.2 Parametric Surfaces

For problems 1 - 10 write down a set of parametric equations for the given surface.

- The plane containing the three points $(1, 4, -2)$, $(-3, 0, 1)$ and $(2, 4, -5)$.
- The portion of the plane $x + 9y + 3z = 8$ that lies in the 1st octant.
- The portion of $x = 2y^2 + 2z^2 - 7$ that is behind $x = 5$.
- The portion of $y = 10 - 3x^2 - 3z^2$ that is in front of the xz -plane.
- The cylinder $x^2 + z^2 = 121$.
- The cylinder $y^2 + z^2 = 6$ for $2 \leq x \leq 9$.
- The sphere $x^2 + y^2 + z^2 = 17$.
- The portion of the sphere of radius 3 with $y \geq 0$ and $z \leq 0$.
- The tangent plane to the surface given by the following parametric equation at the point $(-5, 4, -12)$.

$$\vec{r}(u, v) = (u + 2v)\vec{i} + (u^2 + 3)\vec{j} - 3v^2\vec{k}$$

- The tangent plane to the surface given by the following parametric equation at the point $(1, -11, 19)$.

$$\vec{r}(u, v) = \langle e^{6-2v}, u^2 - 15, 1 - uv^2 \rangle$$

- Determine the surface area of the portion of $3x + 3y + 4z = 16$ that is in the 1st octant.
- Determine the surface area of the portion of $x + 4y + 8z = 4$ that is inside the cylinder $x^2 + y^2 = 16$.
- Determine the surface area of the portion of $z = 6y + 2x^2$ that is above the triangle in the xy -plane with vertices $(0, 0)$, $(8, 0)$ and $(8, 2)$.
- Determine the surface area of the portion of $x = 6 - y^2 - z^2$ that is in front of $x = 2$ with $y \geq 0$.
- Determine the surface area of the portion of $x^2 + y^2 + z^2 = 11$ with $x \geq 0$, $y \leq 0$ and $z \geq 0$.
- Determine the surface area of the portion of the surface given by the following parametric equation that lies above the triangle in the uv -plane with vertices $(0, 0)$, $(10, 2)$ and $(0, 2)$.

$$\vec{r}(u, v) = \langle v^2, 3v, 2u \rangle$$

17. Determine the surface area of the portion of the surface given by the following parametric equation that lies above the region in the uv -plane bounded by $v = \frac{3}{2}u^2$, $u = 2$ and the u -axis.

$$\vec{r}(u, v) = \langle uv, 3uv, v \rangle$$

18. Determine the surface area of the portion of the surface given by the following parametric equation that lies inside the cylinder $u^2 + v^2 = 16$.

$$\vec{r}(u, v) = \langle uv, 1 - 3v, 2 + 3u \rangle$$

17.3 Surface Integrals

1. Evaluate $\iint_S 2x - 3y + z \, dS$ where S is the portion of $x + y + z = 2$ that is in the 1st octant.
2. Evaluate $\iint_S x + y^2 + z^2 \, dS$ where S is the portion of $x = 4 - y^2 - z^2$ that lies in front of $x = -2$.
3. Evaluate $\iint_S 6 \, dS$ where S is the portion of $y = 4z + x^3 + 6$ that lies over the region in the xz -plane with bounded by $z = x^3$, $x = 1$ and the x -axis.
4. Evaluate $\iint_S xyz \, dS$ where S is the portion of $x^2 + y^2 = 36$ between $z = -3$ and $z = 1$.
5. Evaluate $\iint_S z^2 + x \, dS$ where S is the portion of $x^2 + y^2 + z^2 = 4$ with $z \geq 0$.
6. Evaluate $\iint_S 4y \, dS$ where S is the portion of $x^2 + z^2 = 9$ between $y = 2$ and $y = 10 - x$.
7. Evaluate $\iint_S z + 3 \, dS$ where S is the surface of the solid bounded by $z = 2x^2 + 2y^2 - 3$ and $z = 1$. Note that both surfaces of this solid are included in S .
8. Evaluate $\iint_S z \, dS$ where S is the surface of the solid bounded by $y^2 + z^2 = 4$, $x = y - 3$, and $x = 6 - z$. Note that all three surfaces of this solid are included in S .
9. Evaluate $\iint_S 4 + z \, dS$ where S is the portion of the sphere of radius 1 with $z \geq 0$ and $x \leq 0$. Note that all three surfaces of this solid are included in S .

17.4 Surface Integrals of Vector Fields

1. Evaluate $\iint_S \vec{F} \cdot d\vec{S}$ where $\vec{F} = (z - y)\vec{i} + x\vec{j} + 4y\vec{k}$ and S is the portion of $x + y + z = 2$ that is in the 1st octant oriented in the positive z -axis direction.
2. Evaluate $\iint_S \vec{F} \cdot d\vec{S}$ where $\vec{F} = (x - 4)\vec{i} + z\vec{j} - y\vec{k}$ and S is the portion of $x = 4 - y^2 - z^2$ that lies in front of $x = -2$ oriented in the negative x -axis direction.
3. Evaluate $\iint_S \vec{F} \cdot d\vec{S}$ where $\vec{F} = \vec{i} + 4z\vec{j} + (z - y)\vec{k}$ and S is the portion of $y = 4z + x^3 + 6$ that lies over the region in the xz -plane with bounded by $z = x^3$, $x = 1$ and the x -axis oriented in the positive y -axis direction.
4. Evaluate $\iint_S \vec{F} \cdot d\vec{S}$ where $\vec{F} = (x + y)\vec{i} + x\vec{j} + zx^2\vec{k}$ and S is the portion of $x^2 + y^2 = 36$ between $z = -3$ and $z = 1$ oriented outward (i.e. away from the z -axis).
5. Evaluate $\iint_S \vec{F} \cdot d\vec{S}$ where $\vec{F} = z\vec{i} + 3\vec{k}$ and S is the portion of $x^2 + y^2 + z^2 = 4$ with $z \geq 0$ oriented outwards (i.e. away from the origin).
6. Evaluate $\iint_S \vec{F} \cdot d\vec{S}$ where $\vec{F} = -x\vec{i} + (4 + y)\vec{j} - z\vec{k}$ and S is the portion of $x^2 + z^2 = 9$ between $y = 2$ and $y = 10 - x$ oriented inward (i.e. towards from the y -axis).
7. Evaluate $\iint_S \vec{F} \cdot d\vec{S}$ where $\vec{F} = y\vec{i} + 2\vec{j} + (z + 3)^2\vec{k}$ and S is the surface of the solid bounded by $z = 2x^2 + 2y^2 - 3$ and $z = 1$ with the negative orientation. Note that both surfaces of this solid are included in S .
8. Evaluate $\iint_S \vec{F} \cdot d\vec{S}$ where $\vec{F} = (x - y)\vec{i} + z\vec{j} + y\vec{k}$ and S is the surface of the solid bounded by $y^2 + z^2 = 4$, $x = y - 3$, and $x = 6 - z$ with the positive orientation. Note that all three surfaces of this solid are included in S .
9. Evaluate $\iint_S \vec{F} \cdot d\vec{S}$ where $\vec{F} = y\vec{i} - 2\vec{k}$ and S is the portion of the sphere of radius 1 with $z \geq 0$ and $x \leq 0$ with the positive orientation. Note that all three surfaces of this solid are included in S .

17.5 Stokes' Theorem

- Use Stokes' Theorem to evaluate $\iint_S \text{curl} \vec{F} \cdot d\vec{S}$ where $\vec{F} = x^3 \vec{i} + (4y - z^3 y^3) \vec{j} + 2x \vec{k}$ and S is the portion of $z = x^2 + y^2 - 3$ below $z = 1$ with orientation in the negative z -axis direction.
- Use Stokes' Theorem to evaluate $\iint_S \text{curl} \vec{F} \cdot d\vec{S}$ where $\vec{F} = 2y \vec{i} + 3x \vec{j} + (z - x) \vec{k}$ and S is the portion of $y = 11 - 3x^2 - 3z^2$ in front of $y = 5$ with orientation in the positive y -axis direction.
- Use Stokes' Theorem to evaluate $\int_C \vec{F} \cdot d\vec{r}$ where $\vec{F} = (zx^3 - 2z) \vec{i} + xz \vec{j} + yx \vec{k}$ and C is the triangle with vertices $(0, 0, 4)$, $(0, 2, 0)$ and $(2, 0, 0)$. C has a clockwise rotation if you are above the triangle and looking down towards the xy -plane. See the figure below for a sketch of the curve.

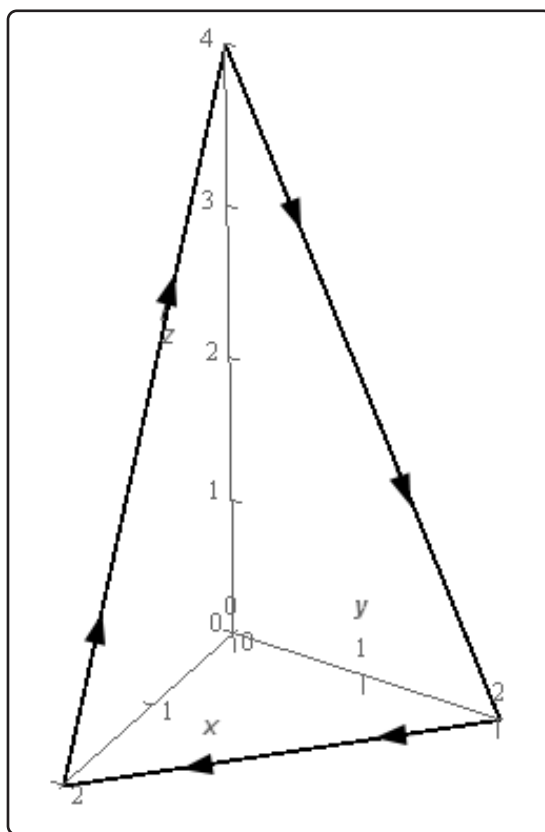

4. Use Stokes' Theorem to evaluate $\int_C \vec{F} \cdot d\vec{r}$ where $\vec{F} = x^2\vec{i} - 4z\vec{j} + xy\vec{k}$ and C is the circle of radius 1 at $x = -3$ and perpendicular to the x -axis. C has a counter clockwise rotation if you are looking down the x -axis from the positive x -axis to the negative x -axis. See the figure below for a sketch of the curve.

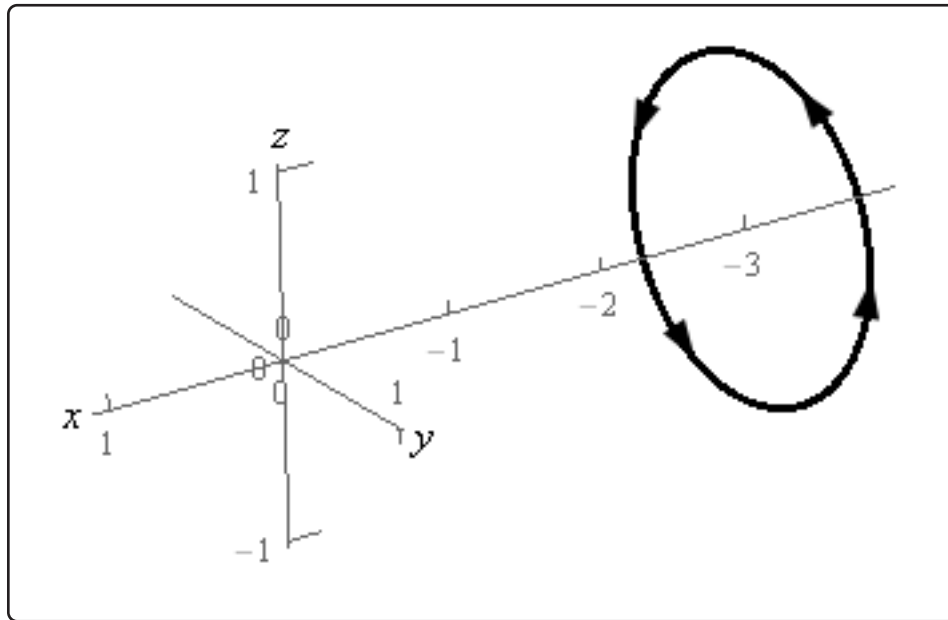

17.6 Divergence Theorem

1. Use the Divergence Theorem to evaluate $\iint_S \vec{F} \cdot d\vec{S}$ where
 $\vec{F} = (3x - zx^2) \vec{i} + (x^3 - 1) \vec{j} + (4y^2 + x^2z^2) \vec{k}$ and S is the surface of the box with $0 \leq x \leq 1$, $-3 \leq y \leq 0$ and $-2 \leq z \leq 1$. Note that all six sides of the box are included in S .
2. Use the Divergence Theorem to evaluate $\iint_S \vec{F} \cdot d\vec{S}$ where $\vec{F} = 4x \vec{i} + (1 - 6y) \vec{j} + z^3 \vec{k}$ and S is the surface of the sphere of radius 2 with $z \geq 0$, $y \leq 0$ and $x \geq 0$. Note that all four surfaces of this solid are included in S .
3. Use the Divergence Theorem to evaluate $\iint_S \vec{F} \cdot d\vec{S}$ where $\vec{F} = -xy \vec{i} + (z - 1) \vec{j} + z^3 \vec{k}$ and S is the surface of the solid bounded by $y = 4x^2 + 4z^2 - 1$ and the plane $y = 7$. Note that both of the surfaces of this solid included in S .
4. Use the Divergence Theorem to evaluate $\iint_S \vec{F} \cdot d\vec{S}$ where
 $\vec{F} = (4x - z^2) \vec{i} + (x + 3z) \vec{j} + (6 - z) \vec{k}$ and S is the surface of the solid bounded by the cylinder $x^2 + y^2 = 36$ and the planes $z = -2$ and $z = 3$. Note that both of the surfaces of this solid included in S .